

[54] COMBINED PACKAGING AND SHIPPING CONTAINER

[76] Inventors: John S. Driscoll, 221 LaFox, Algonquin, Ill. 60102; John J. Cushing, 6259 N. Artesian, Chicago, Ill. 60659

[**] Term: 14 Years

[21] Appl. No.: 209,650

[22] Filed: Nov. 24, 1980

[51] Int. Cl. D9-03

[52] U.S. Cl. D9/345; D9/425; D9/456

[58] Field of Search D9/345, 341, 344, 346, D9/347, 348, 424, 425, 426, 432, 456; 229/27, 28 R, 6 R, 15; 220/20, 21; 206/389, 214, 303

[56] References Cited

U.S. PATENT DOCUMENTS

- D. 171,131 12/1953 Hudson D9/347
- D. 184,403 2/1959 Krone D9/345

- D. 213,860 4/1969 Dittman D9/456
- D. 235,811 7/1975 Parsons D9/347 X
- D. 243,914 4/1977 Marubashi et al. D9/425 X
- 3,442,378 5/1969 Wolfe 229/2.5 X

Primary Examiner—Robert C. Spangler
Attorney, Agent, or Firm—Ralph R. Rath

[57] CLAIM

The ornamental design for a combined packaging and shipping container, as shown and described.

DESCRIPTION

FIG. 1 is a perspective view of a combined packaging and shipping container showing our design;
 FIG. 2 is a top plan view;
 FIG. 3 is a front elevational view, the opposite side elevational views and the rear elevational view appearing substantially identical;
 FIG. 4 is a bottom plan view;
 FIG. 5 is an enlarged fragmentary cross-sectional view, as viewed along line 5-5 of FIG. 2; and,
 FIG. 6 is an enlarged fragmentary cross-sectional view, as viewed along line 6-6 of FIG. 5.

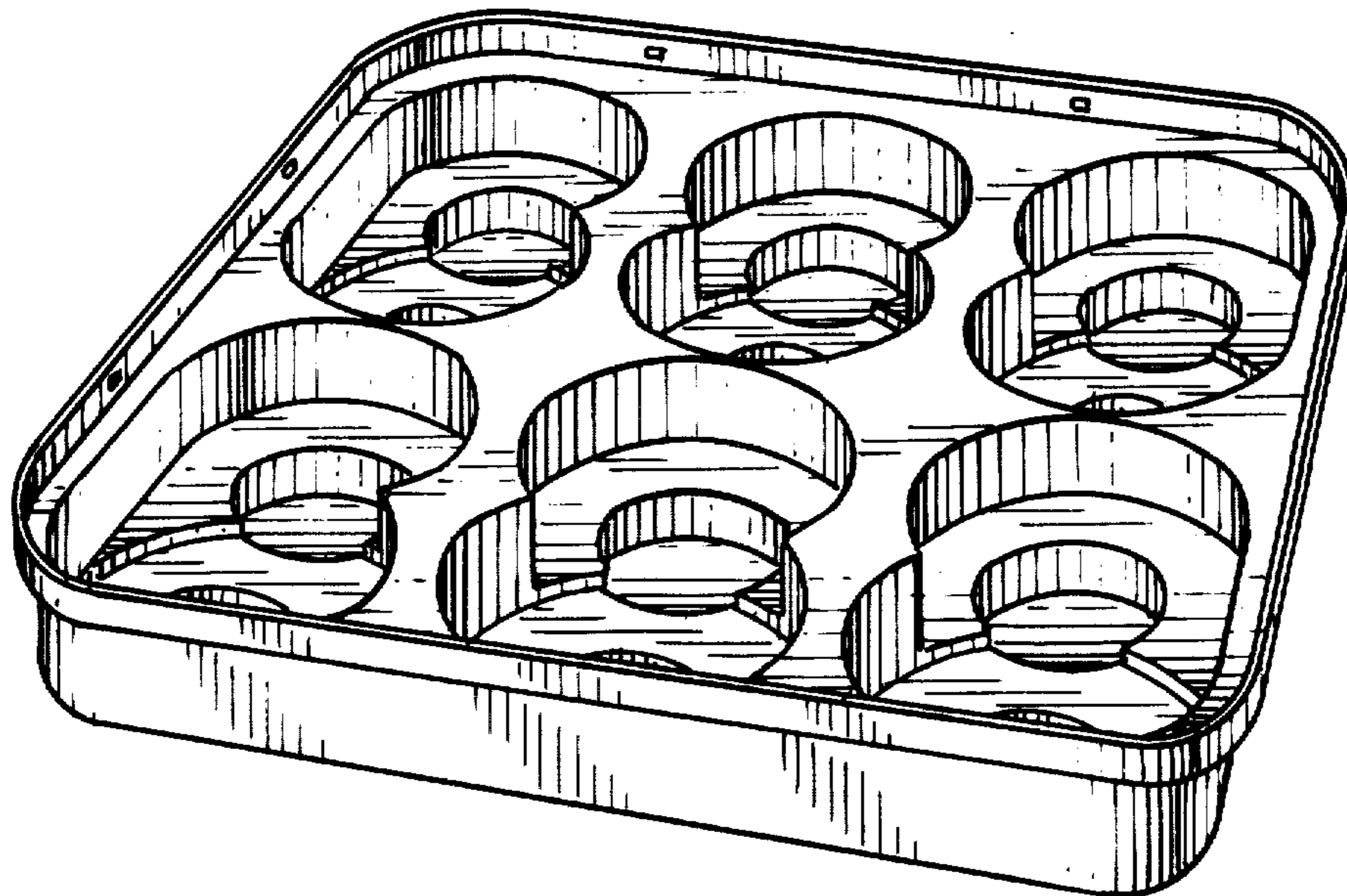

Fig. 1.

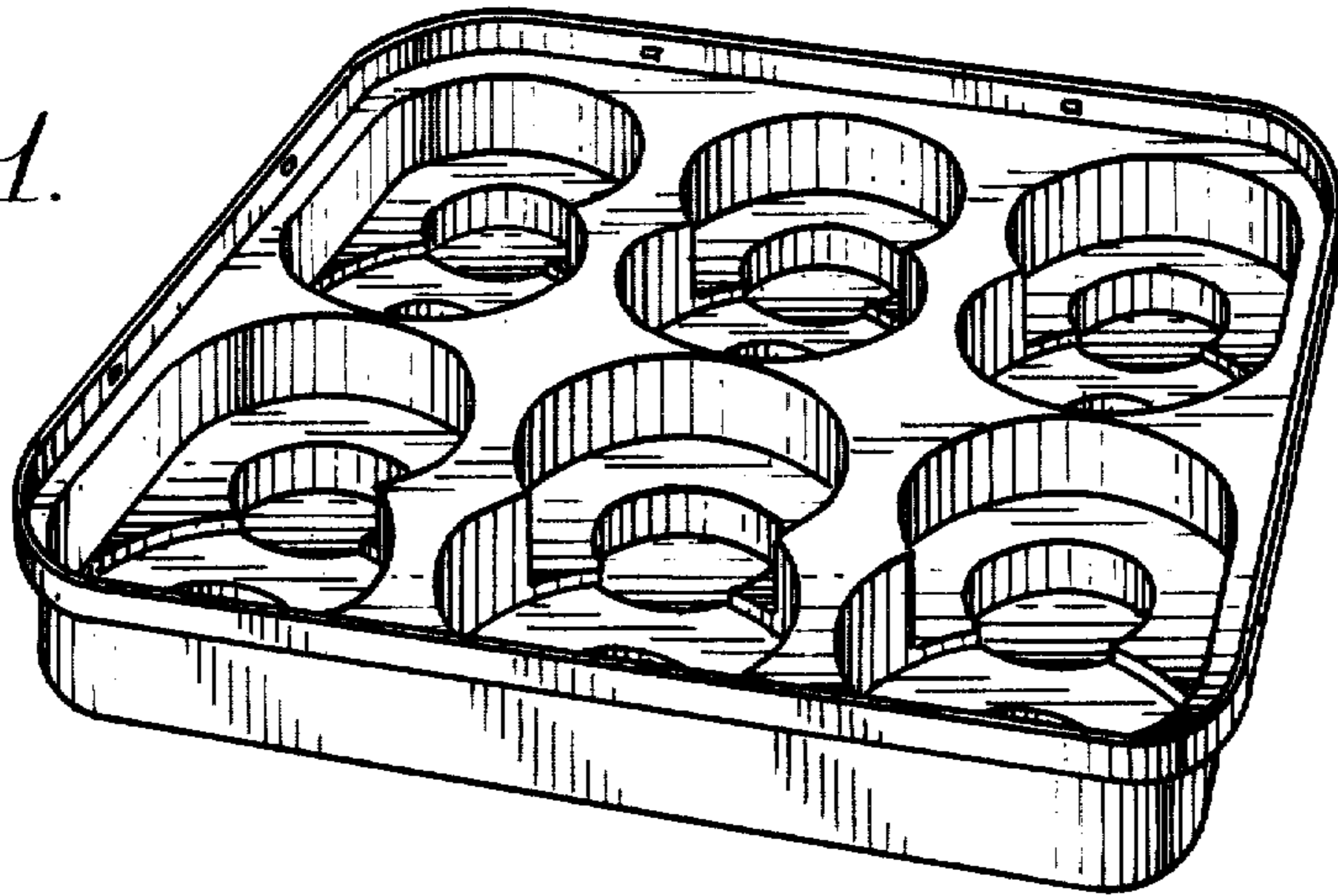

Fig. 2.

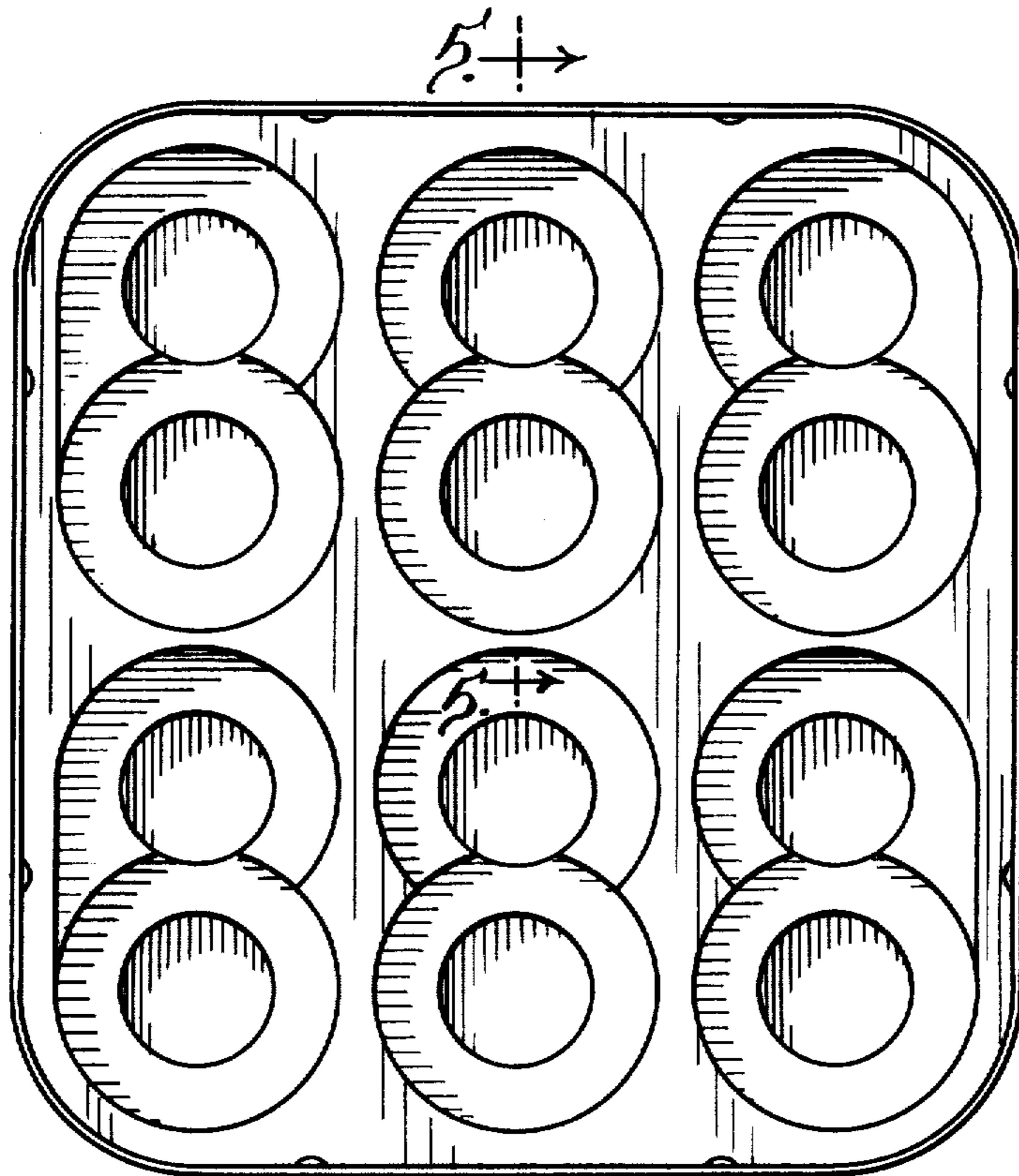

Fig. 3.

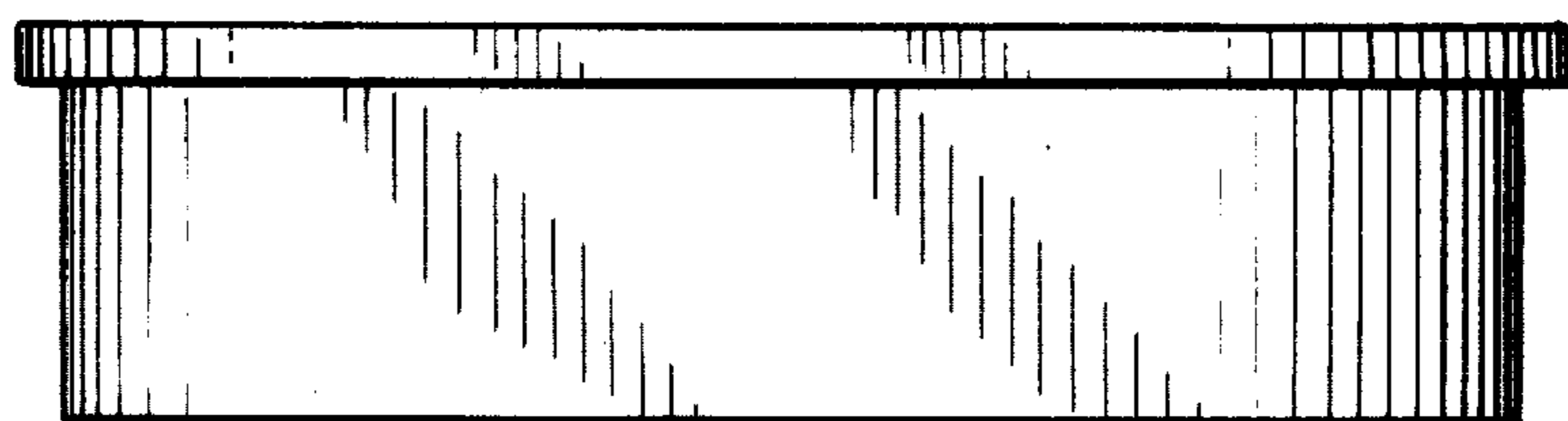

Fig. 4.

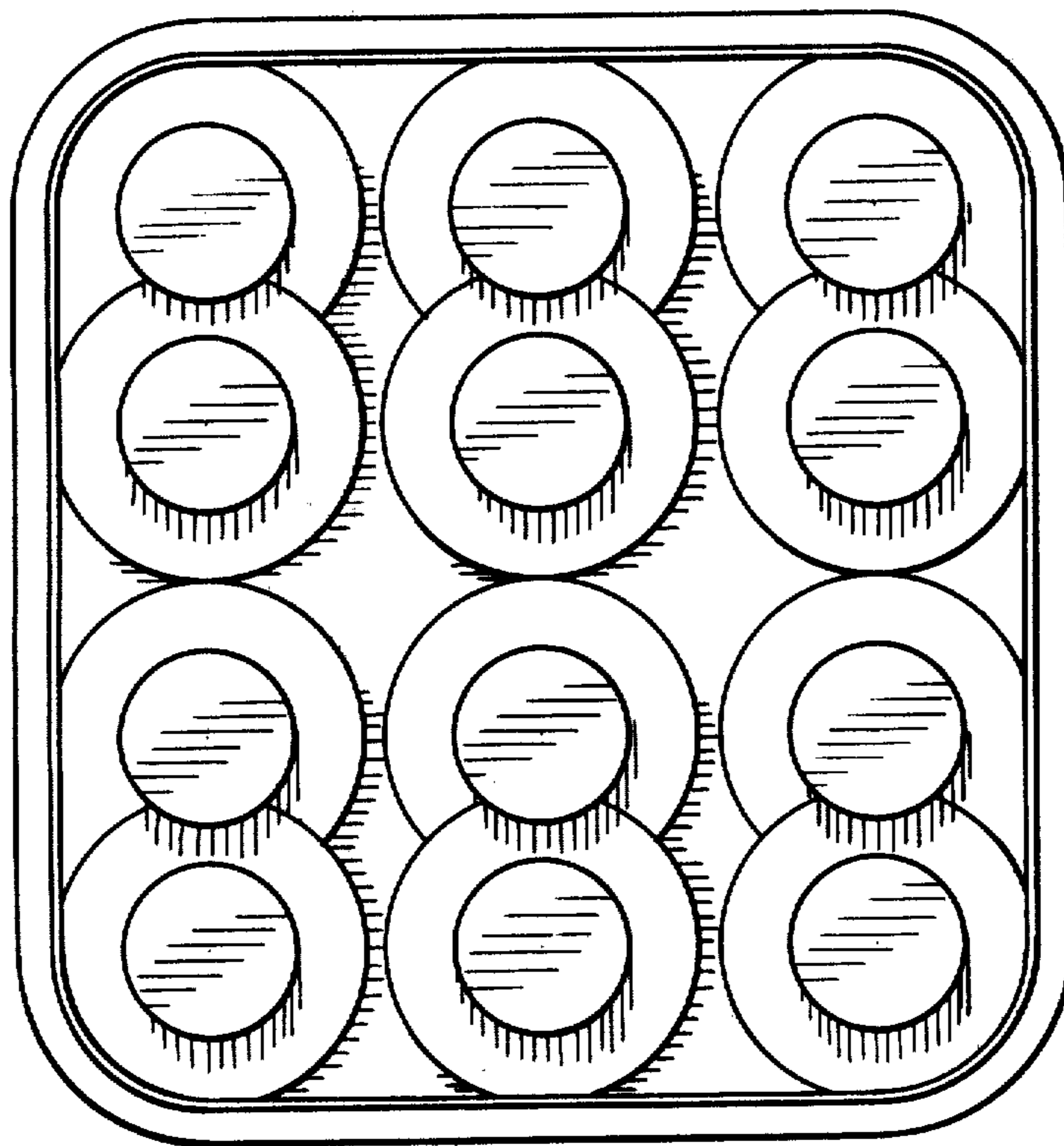

Fig. 5.

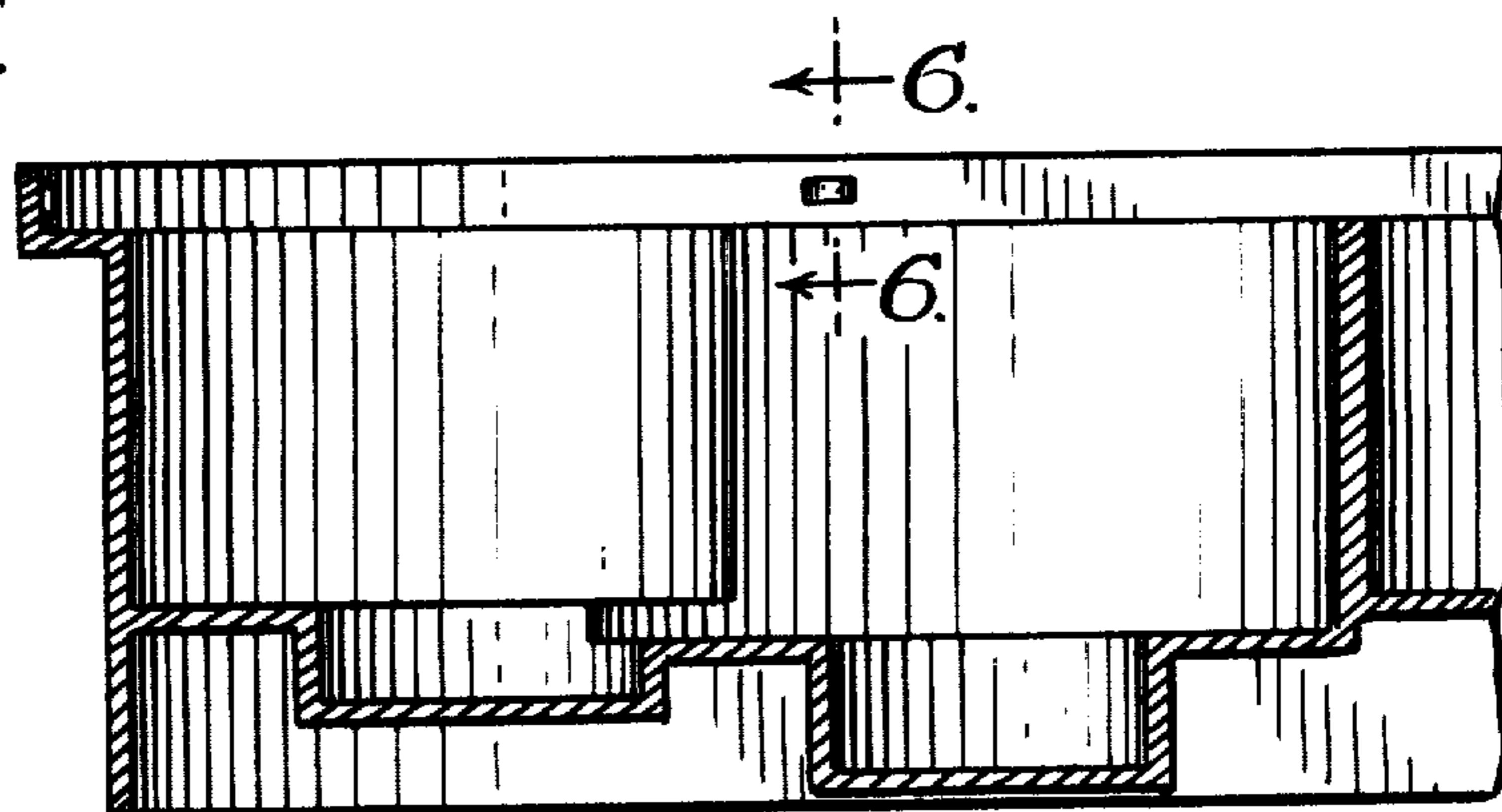

Fig. 6.

