

[54] VEHICLE WHEEL

[75] Inventor: Masakazu Hayashi, Higashi-Osaka, Japan

[73] Assignee: Kabushiki Kaisha Hayashi Racing, Osaka, Japan

[\*\*] Term: 14 Years

[21] Appl. No.: 180,500

[22] Filed: Aug. 22, 1980

[51] Int. Cl. .... D12-16

[52] U.S. Cl. .... D12/211

[58] Field of Search ..... D12/209, 211; 301/64 R, 301/64 SD, 65, 66

[56] References Cited

U.S. PATENT DOCUMENTS

- D. 230,726 3/1974 Cravits ..... D12/211
- D. 256,456 8/1980 Blanchard ..... D12/211

OTHER PUBLICATIONS

Road & Track, 2/78, p. 111, Sportstar Wheel, center right side of page.  
Hot Rod, 12/79, p. 99, Camaro Wheel, bottom center of page.

Primary Examiner—James M. Gandy  
Attorney, Agent, or Firm—Armstrong, Nikaido, Marmelstein & Kubovcik

[57] CLAIM

The ornamental design for a vehicle wheel, as shown and described.

DESCRIPTION

FIG. 1 is a front elevational view of a vehicle wheel showing my new design.

FIG. 2 is a rear elevational view thereof.

FIG. 3 is a bottom plan view of FIG. 1.

FIG. 4 is a sectional view taken along line IV—IV of FIG. 1.

FIG. 5 is a sectional view taken along line V—V of FIG. 1.

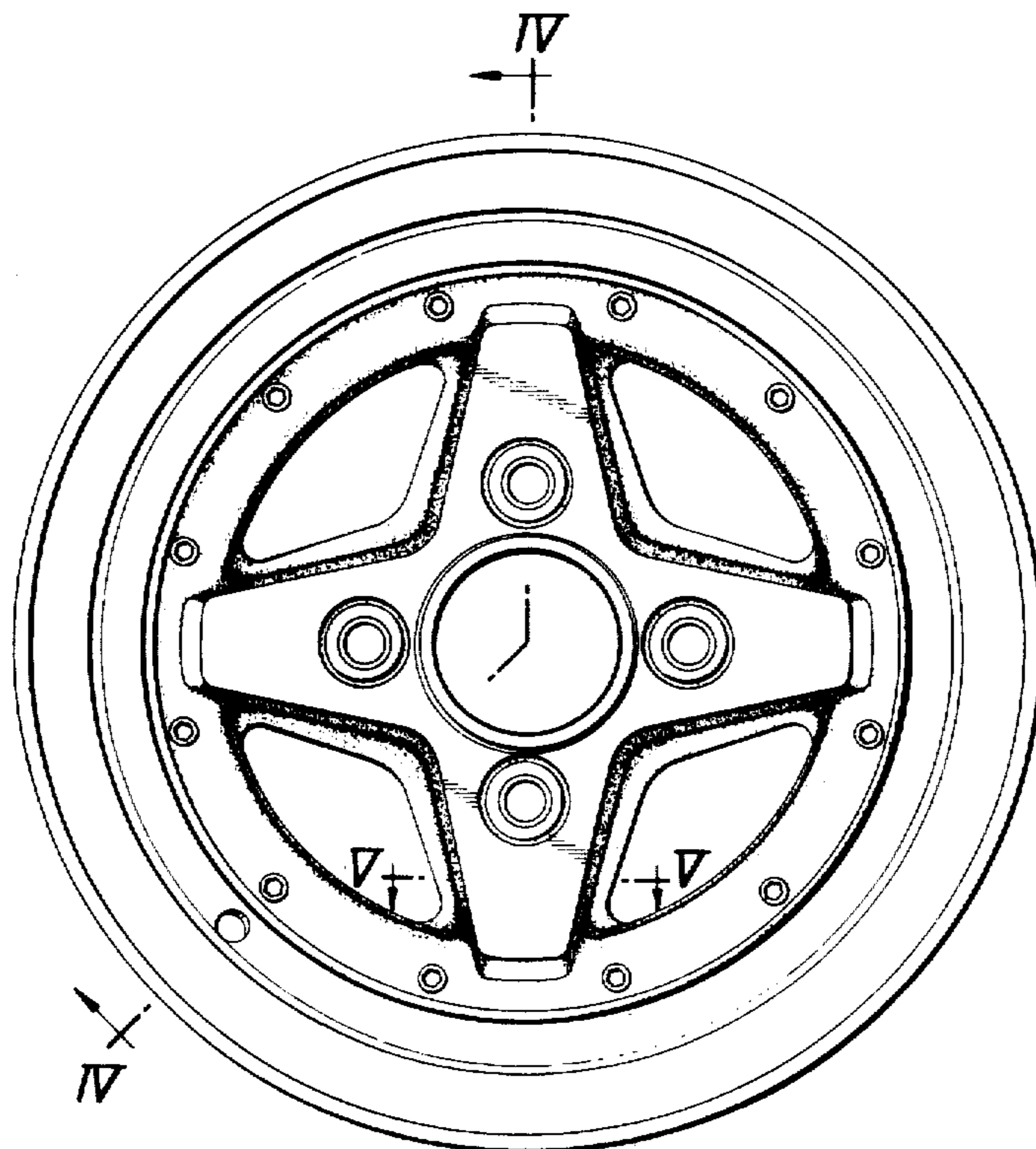
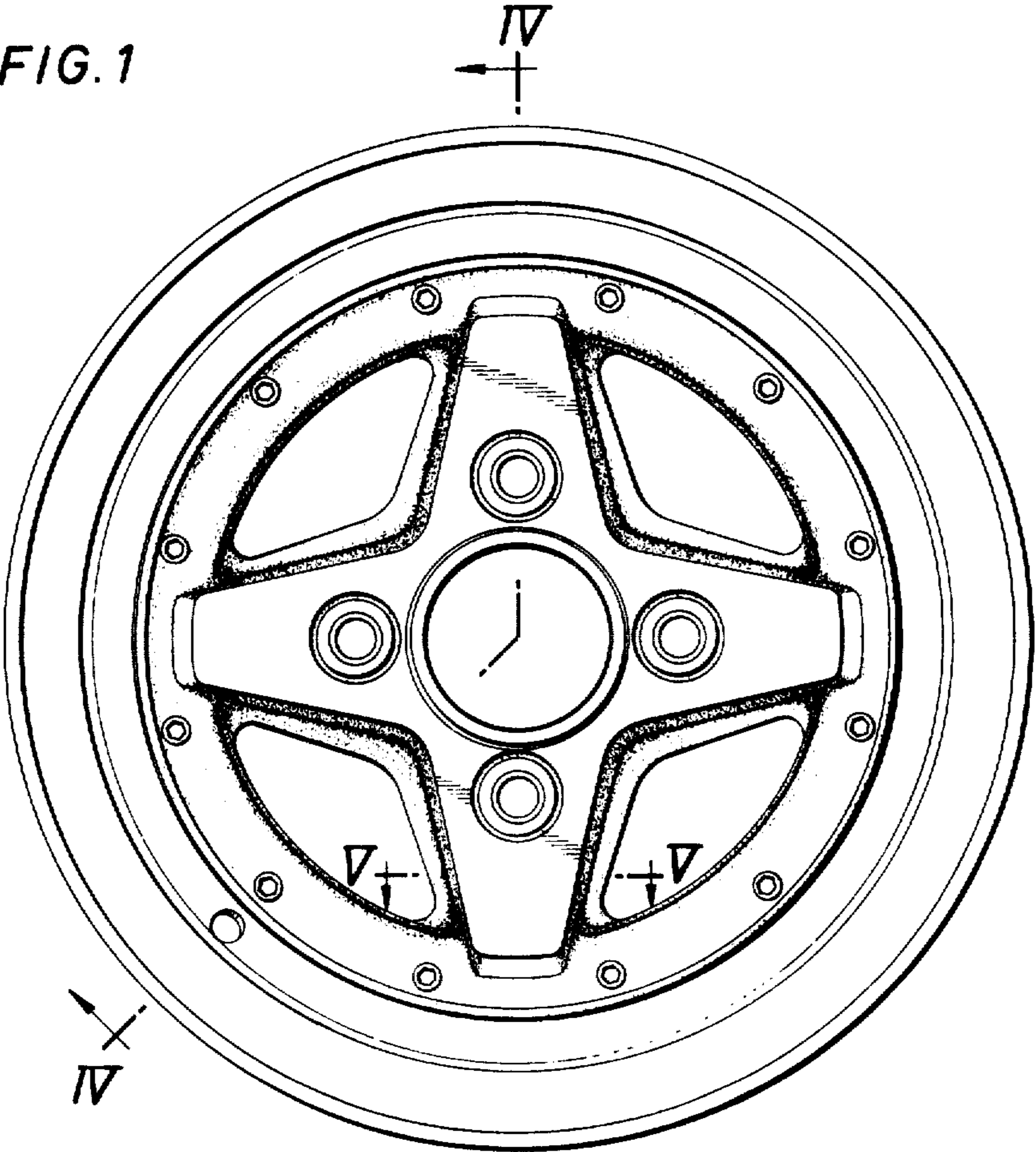
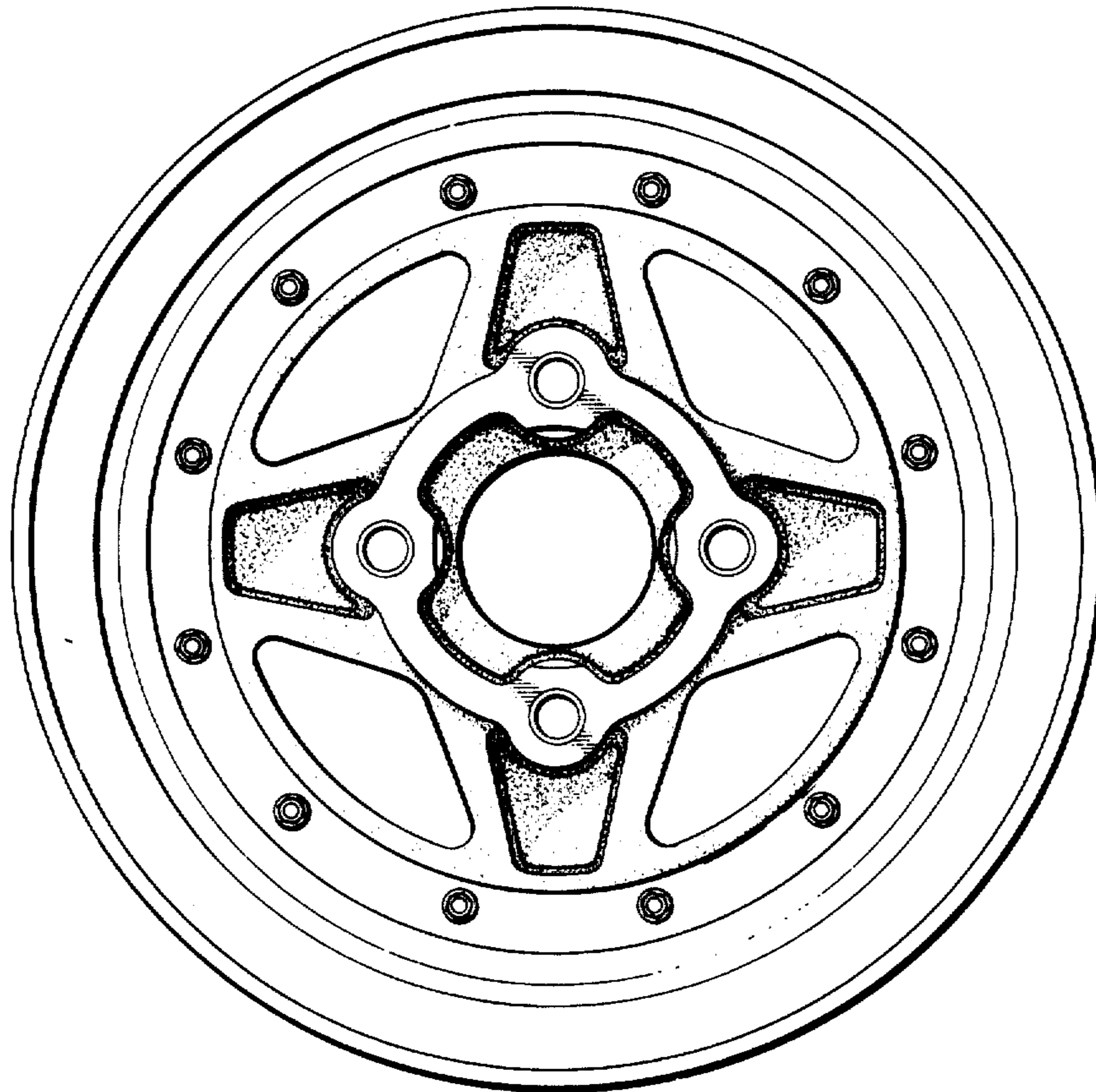

FIG. 1



*FIG. 2*



*FIG. 5*

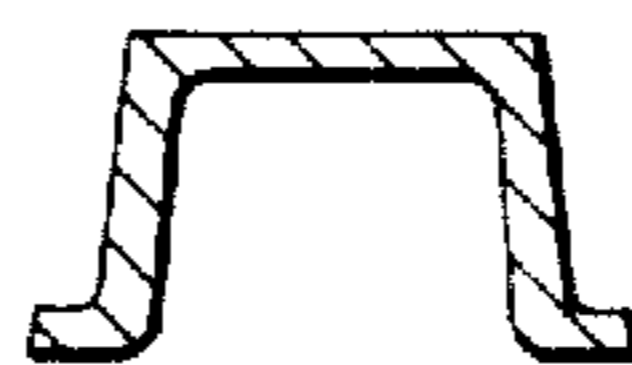

*FIG. 3*

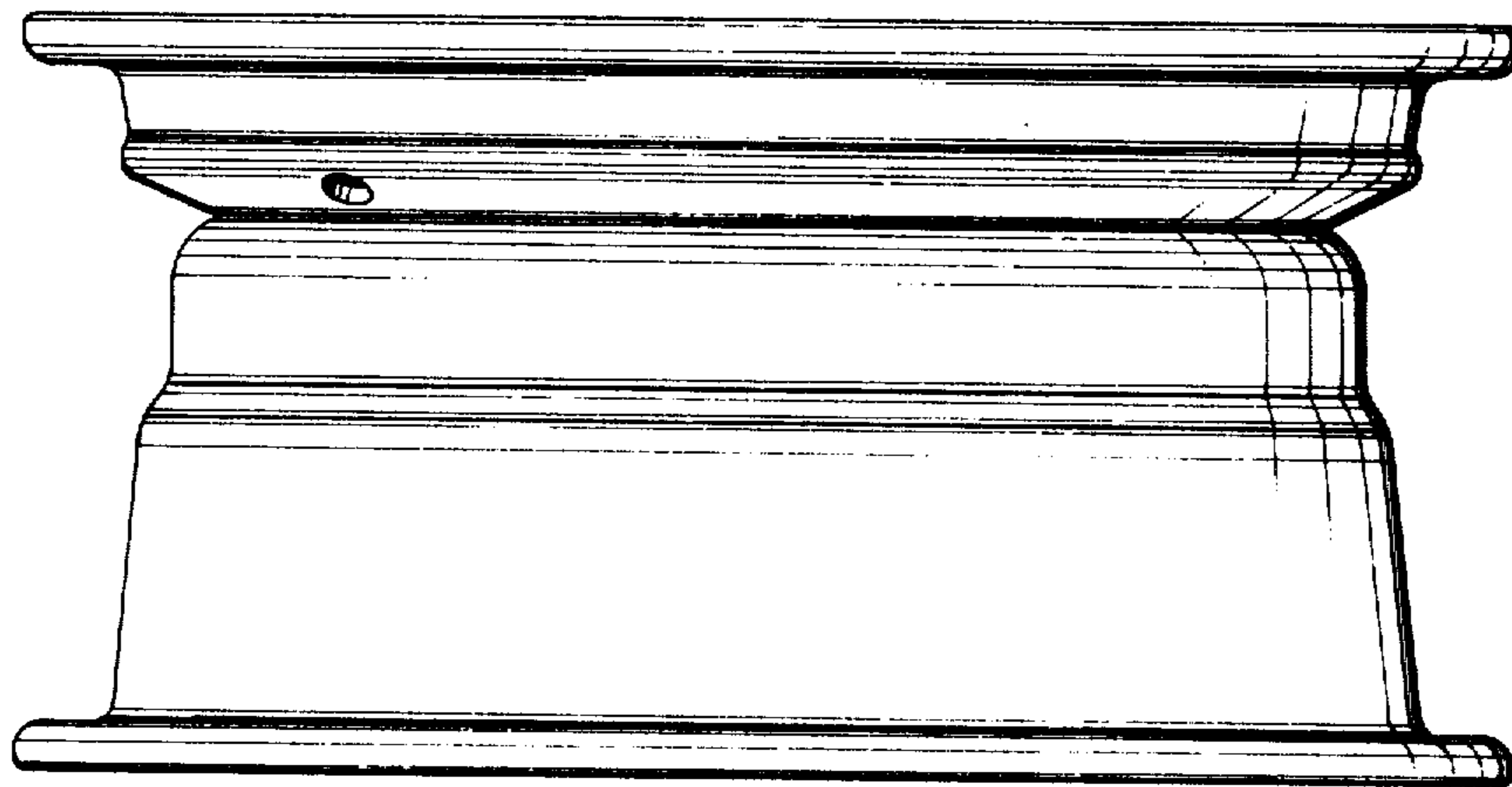

FIG. 4

