

[54] TRUCK CAB

[76] Inventor: Robert P. Martin, Jr., c/o Martin Sheet Metal, Inc., 7108 Madison Ave., Cleveland, Ohio 41402

[**] Term: 14 Years

[21] Appl. No.: 180,515

[22] Filed: Aug. 22, 1980

[51] Int. Cl. D12-16

[52] U.S. Cl. D12/96; D15/30

[58] Field of Search D12/97, 96; D34/37; D15/30; 296/190; 180/89.12

[56]

References Cited

U.S. PATENT DOCUMENTS

D. 140,373 2/1945 Allen D12/96
D. 142,761 10/1945 Zeiler D15/30

D. 195,943 8/1963 Dodge D15/30

Primary Examiner—James M. Gandy
Attorney, Agent, or Firm—Pearne, Gordon, Sessions, McCoy & Granger

[57]

CLAIM

The ornamental design for a truck cab, substantially as shown and described.

DESCRIPTION

FIG. 1 is a perspective view of the truck cab, showing the front, top and one side thereof;
FIG. 2 is a partial rear elevational view thereof, it being understood that the lower rear edges of the cab side wall and the inside of the lower front wall of said cab have been omitted for convenience of illustration;
FIG. 3 is a side elevational view thereof, the opposite side being a mirror image of that shown; and
FIG. 4 is a front elevational view thereof.

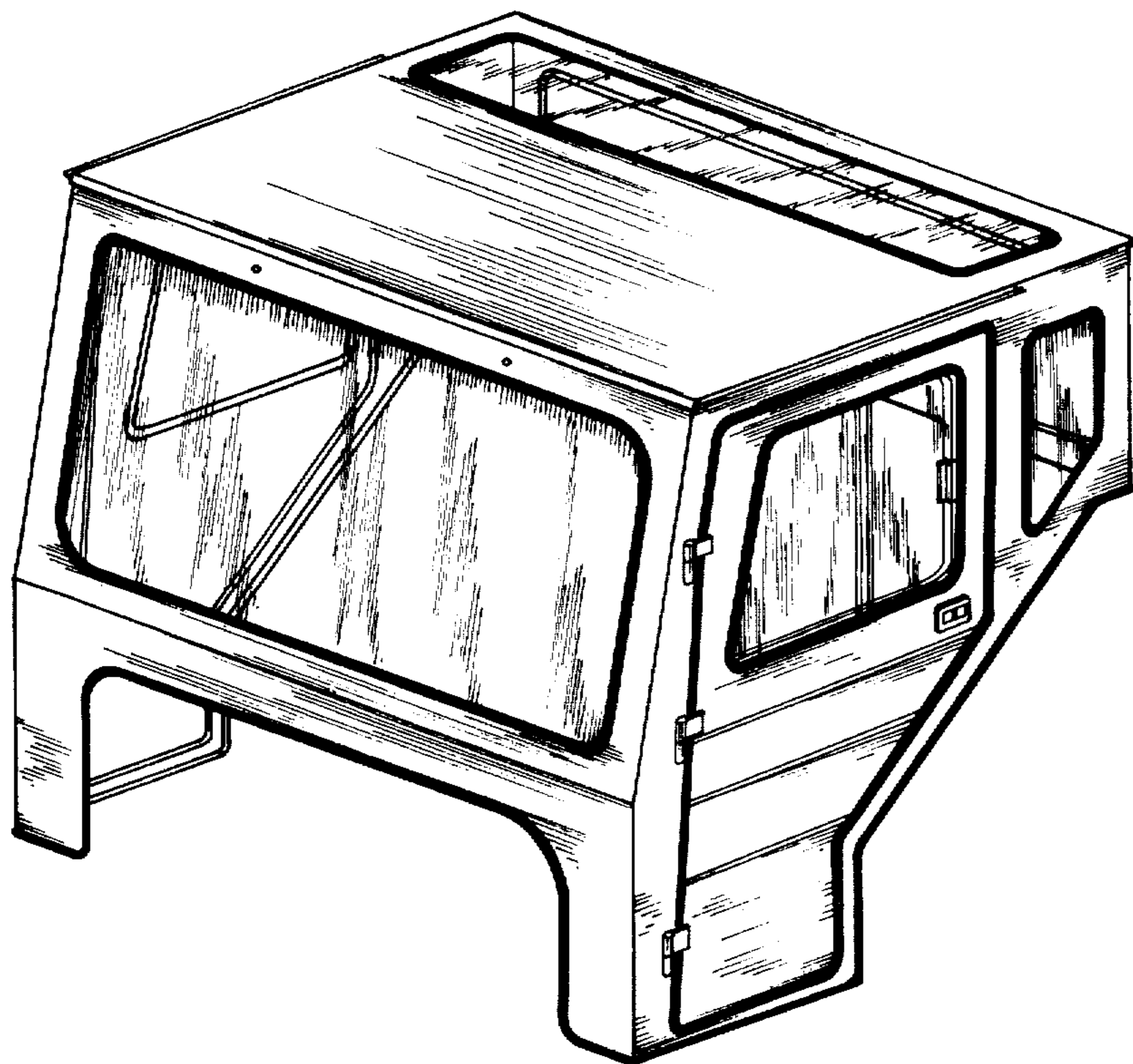

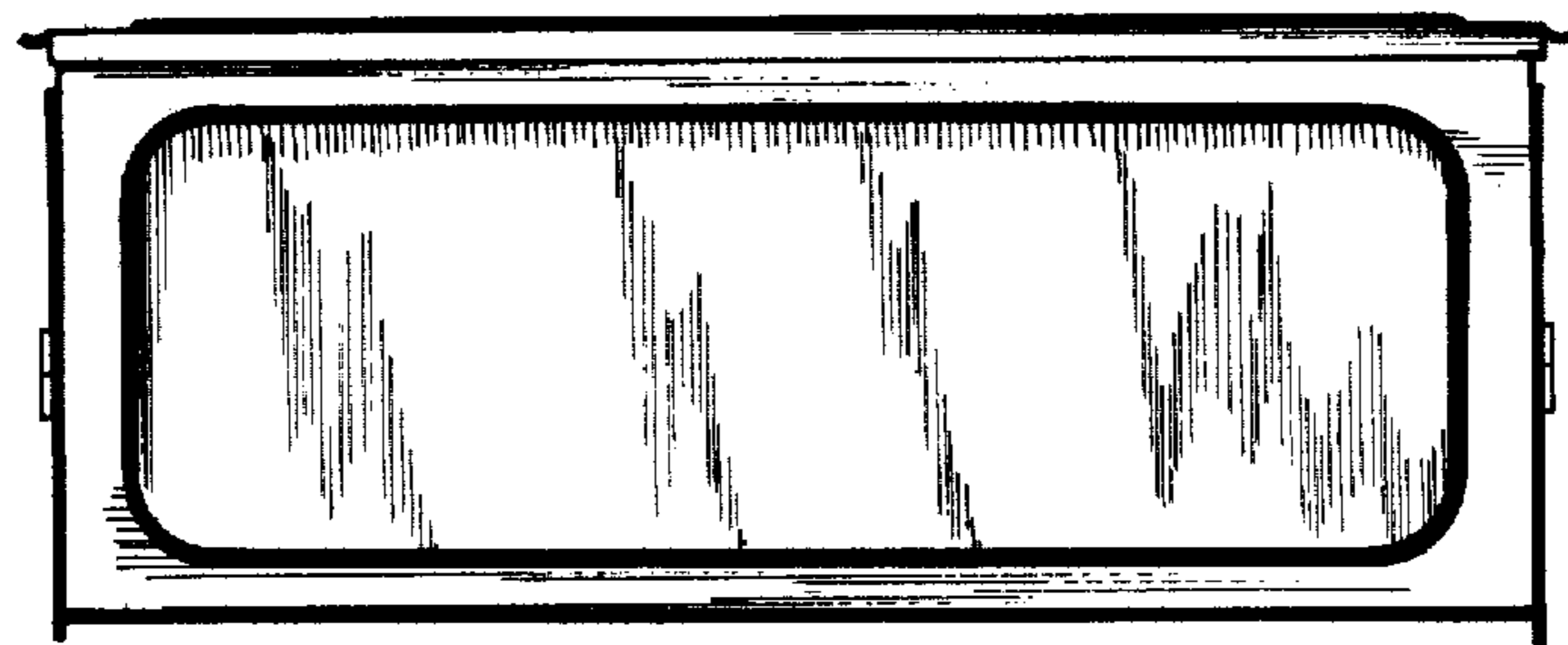
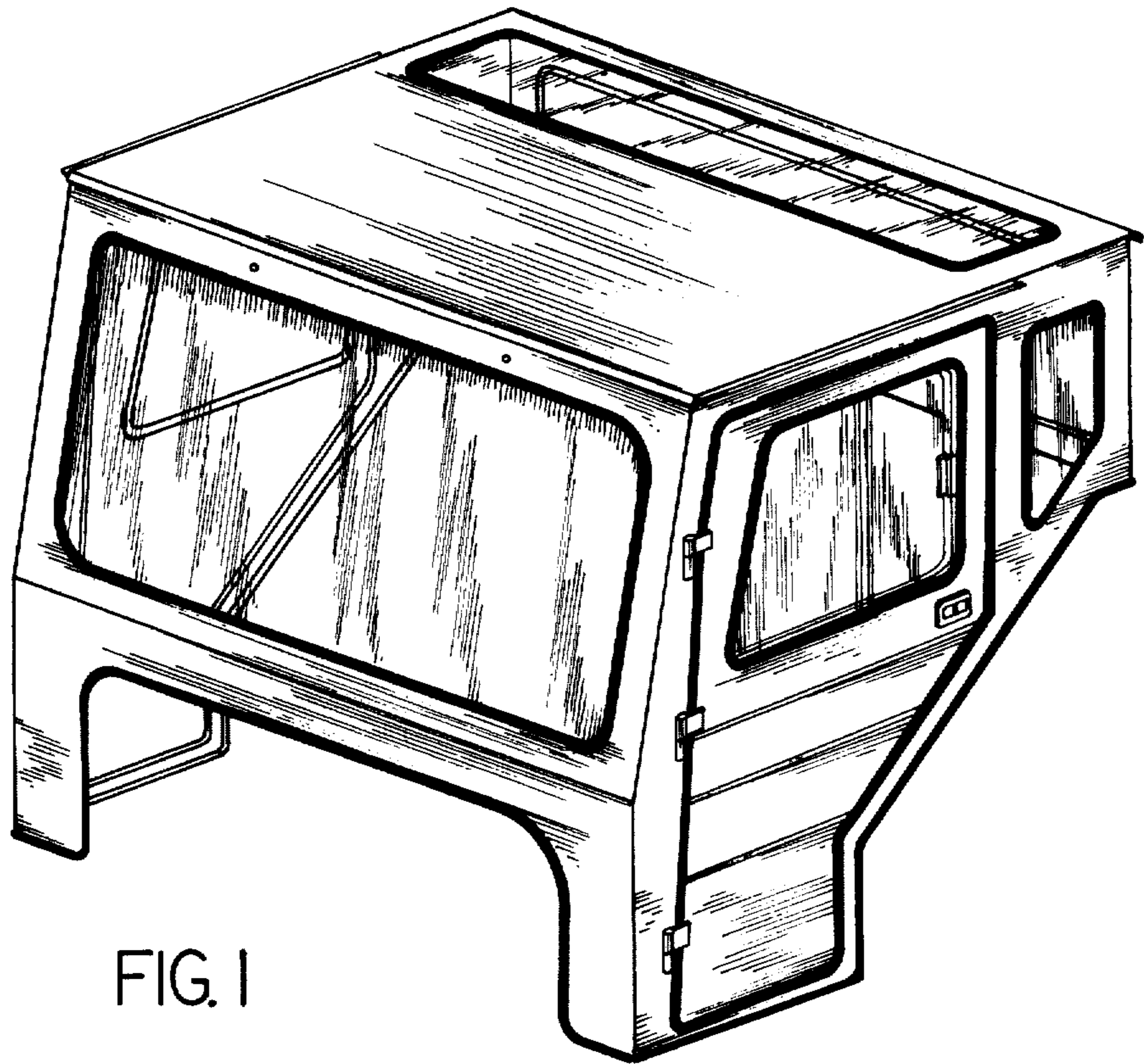

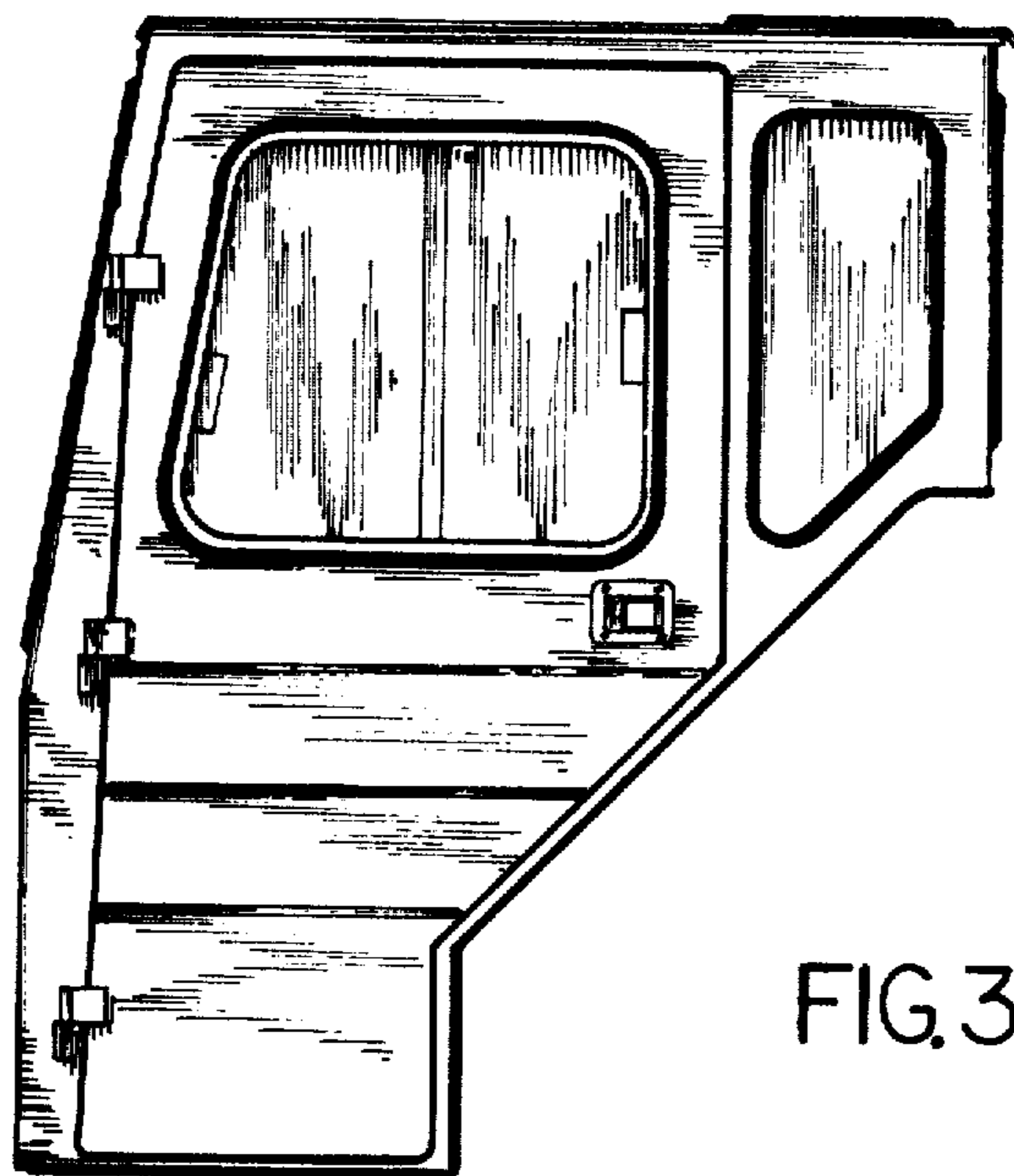

FIG.3

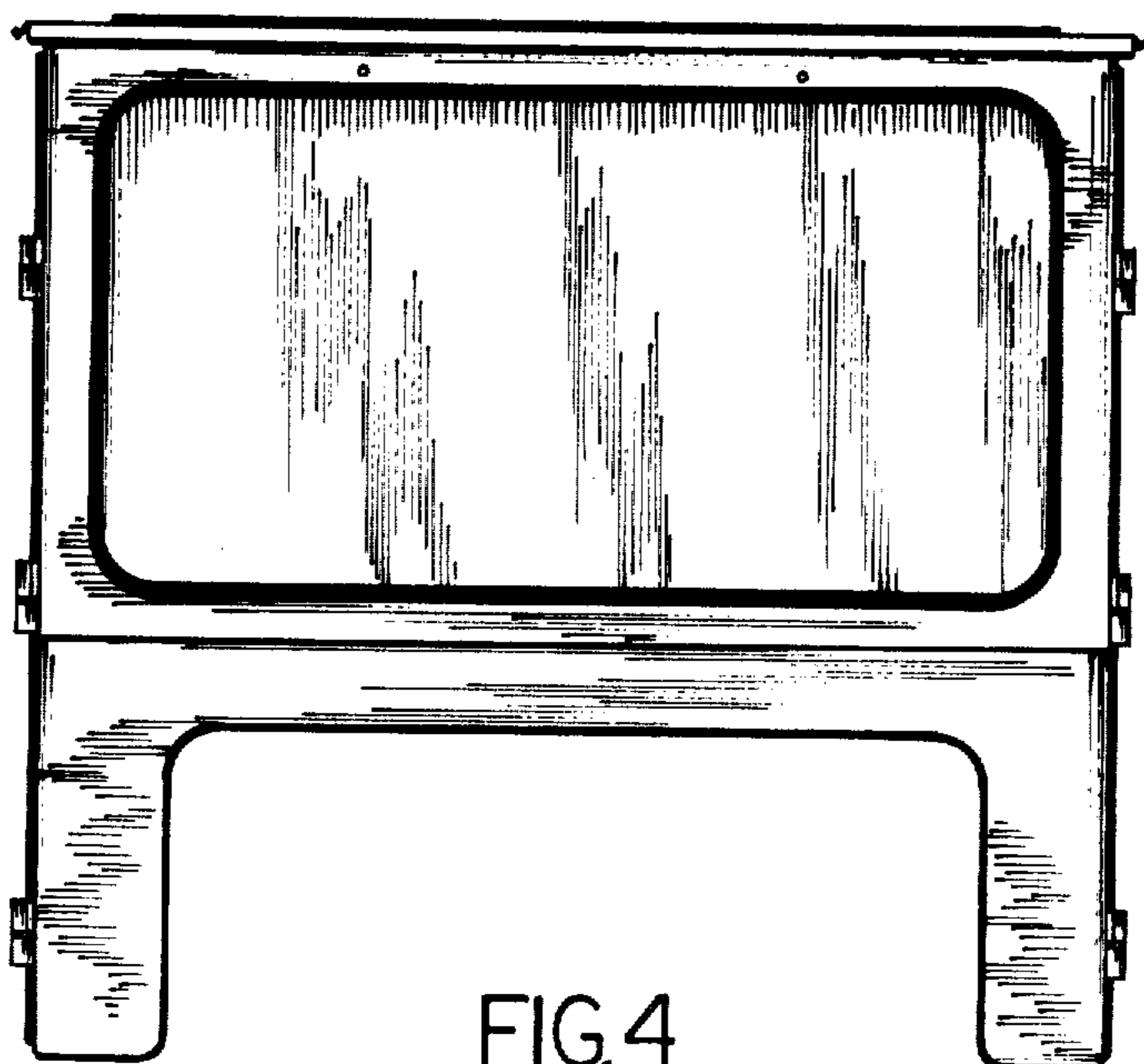

FIG.4