

[54] **PLASTIC MOUNT FOR STAMPING DIE**  
[75] **Inventor:** Edwin W. Goldstein, Scarsdale, N.Y.  
[73] **Assignee:** Crown Marking Equipment Co., Philadelphia, Pa.  
[\*\*] **Term:** 14 Years  
[21] **Appl. No.:** 225,976  
[22] **Filed:** Jan. 19, 1981

[51] **Int. Cl.** ..... D19-02  
[52] **U.S. Cl.** ..... D18/15  
[58] **Field of Search** ..... D18/13-15, D18/18; 101/368, 371-373, 405, 406

[56] **References Cited**  
**U.S. PATENT DOCUMENTS**  
1,952,302 3/1934 Weissman ..... 101/405  
3,302,566 2/1967 Blanchet ..... 101/405  
3,759,180 9/1973 Gibbons et al. .... D18/18 X

**OTHER PUBLICATIONS**

Flyer from *City Marking Devices Corp.*, N.Y., N.Y., p. 1—"Magna Stamp".

*Primary Examiner*—Louis S. Zarfes  
*Attorney, Agent, or Firm*—Hedman, Casella, Gibson & Costigan

[57] **CLAIM**

The ornamental design for a plastic mount for stamping die, as shown.

**DESCRIPTION**

FIG. 1 is a perspective view of a plastic mount for stamping die showing my new design; FIG. 2 is a top plan view thereof; FIG. 3 is a front elevational view thereof; FIG. 4 is a side elevational view taken from the right of FIG. 3; FIG. 5 is a rear elevational view thereof; and FIG. 6 is a bottom plan view thereof.

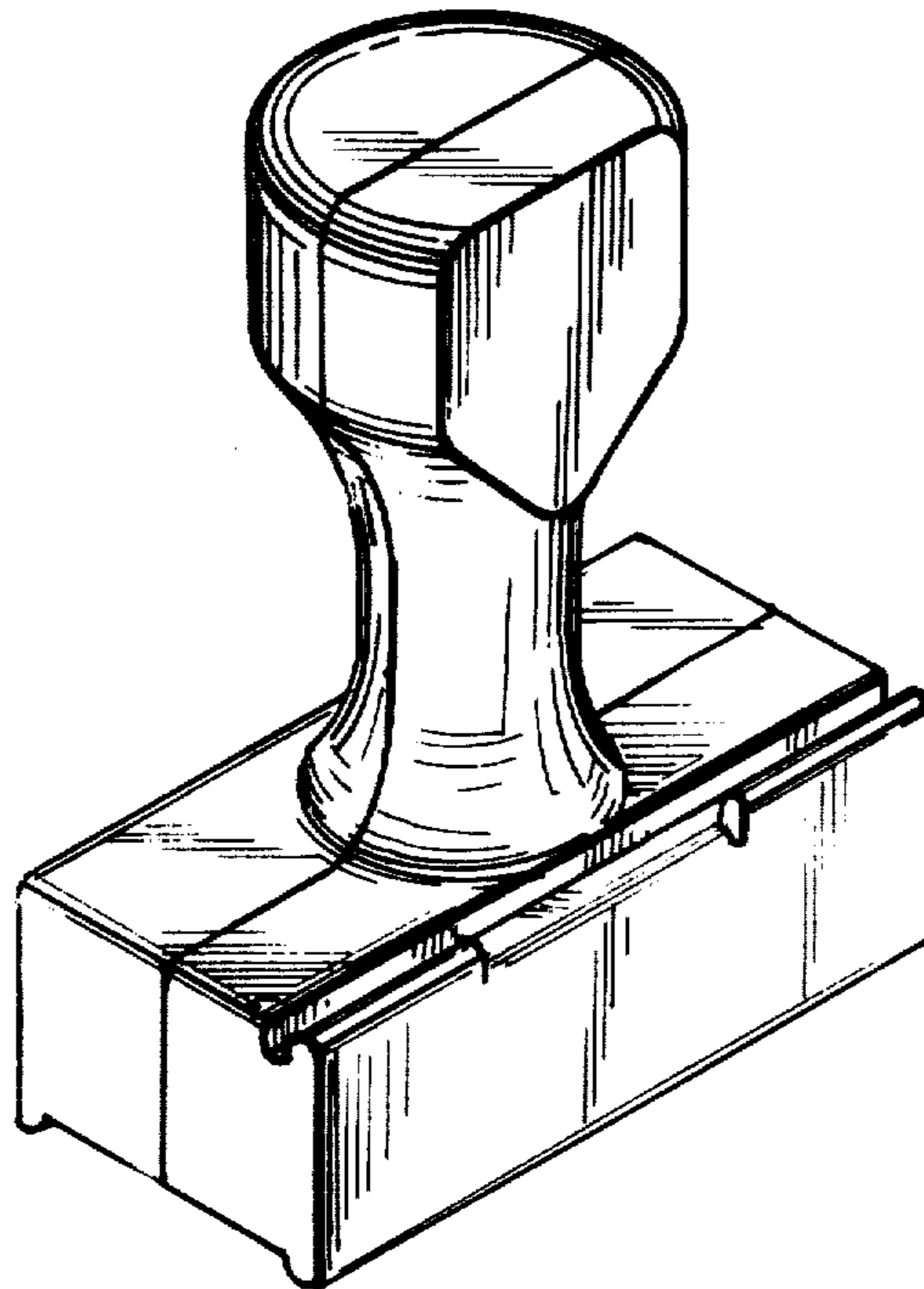

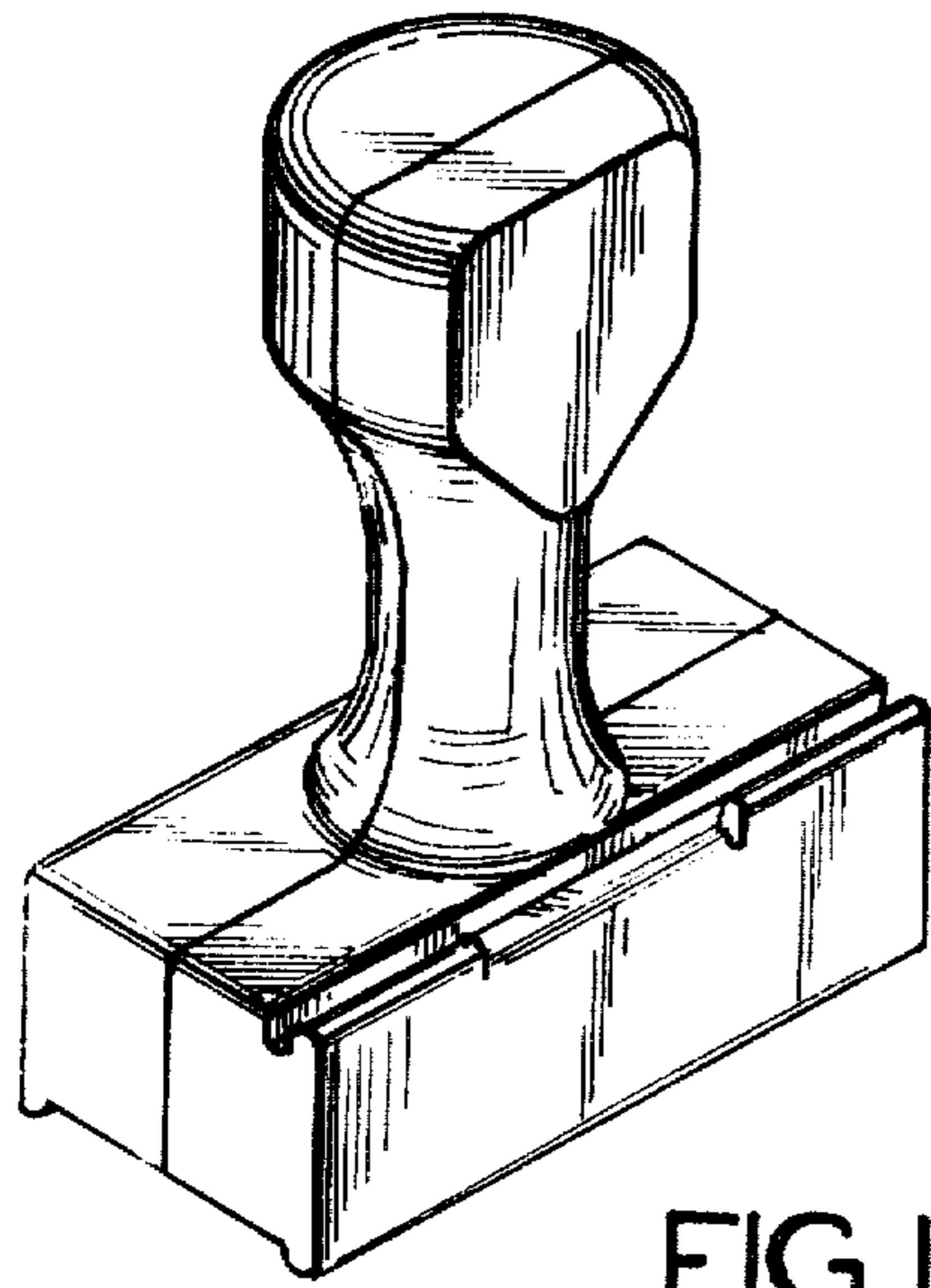

FIG. 1

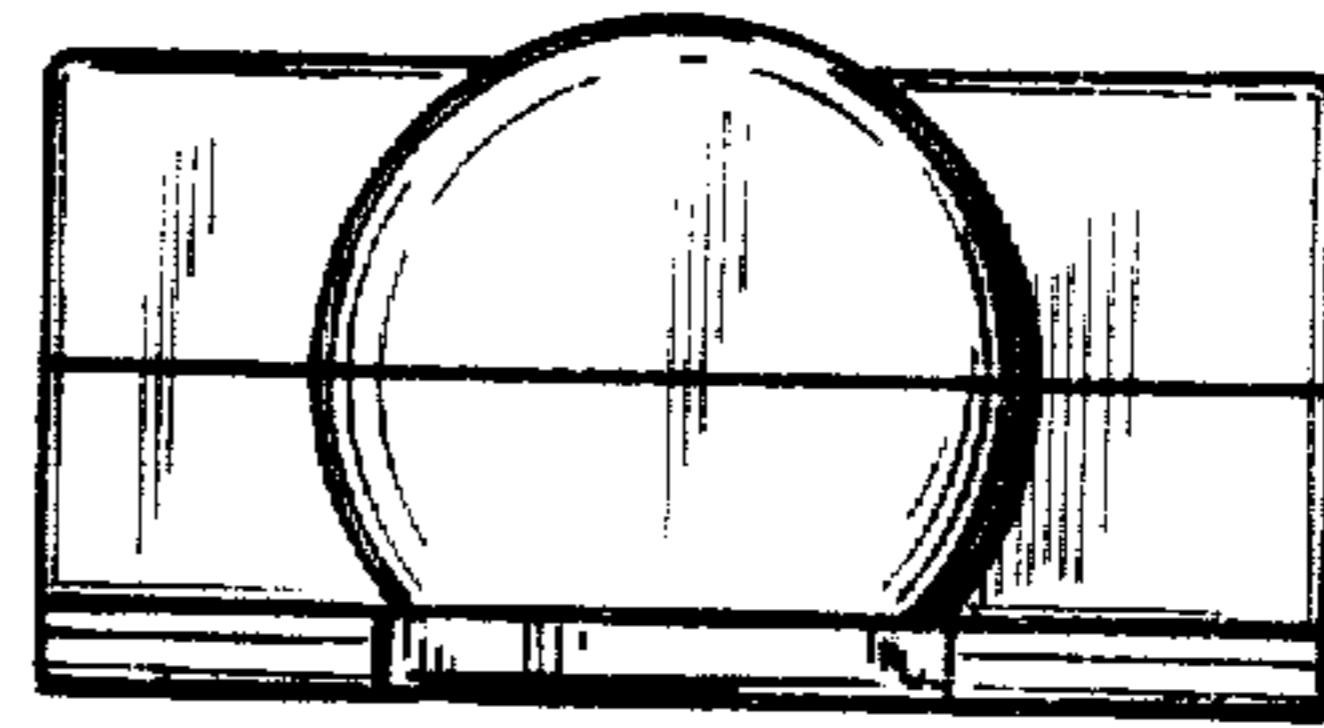

FIG. 2

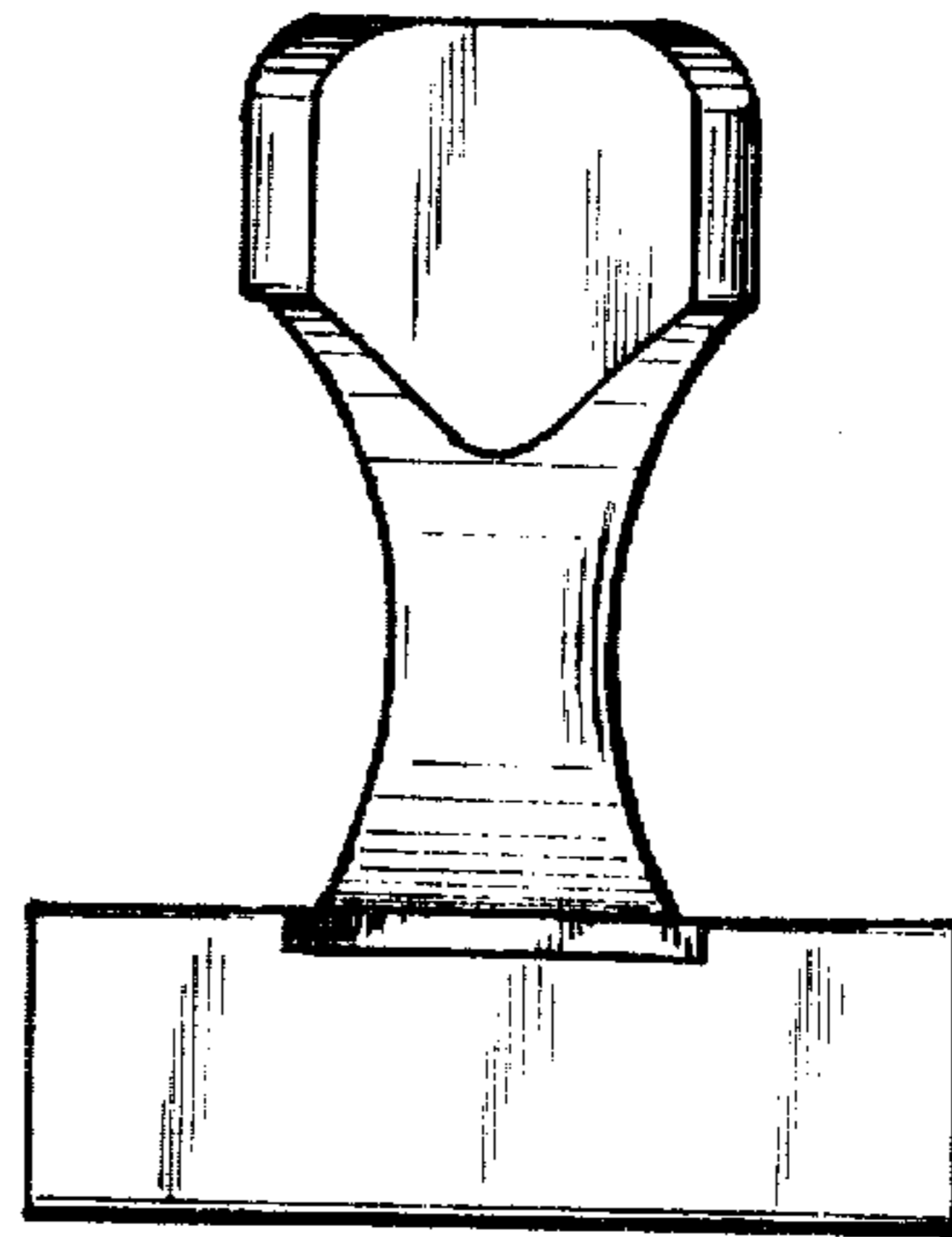

FIG. 3

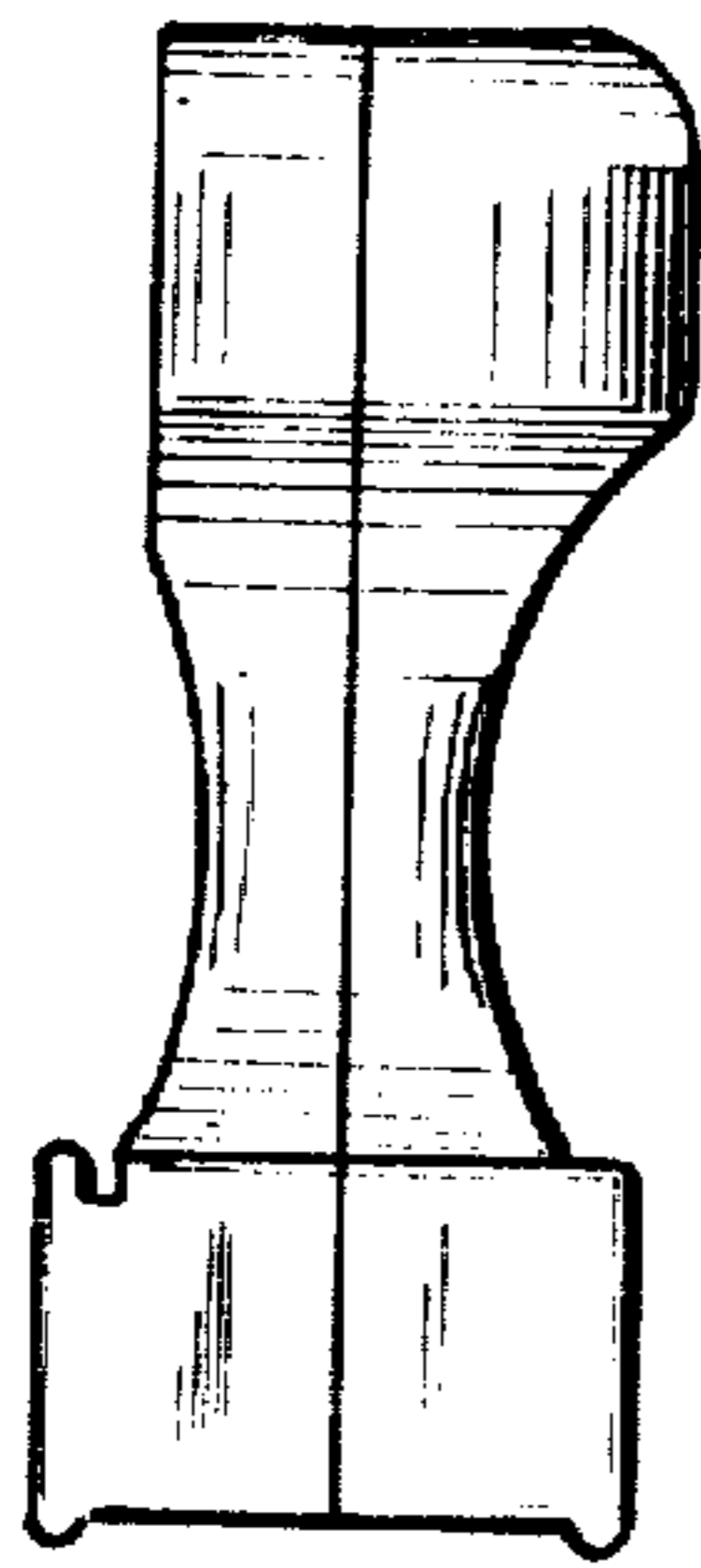

FIG. 4

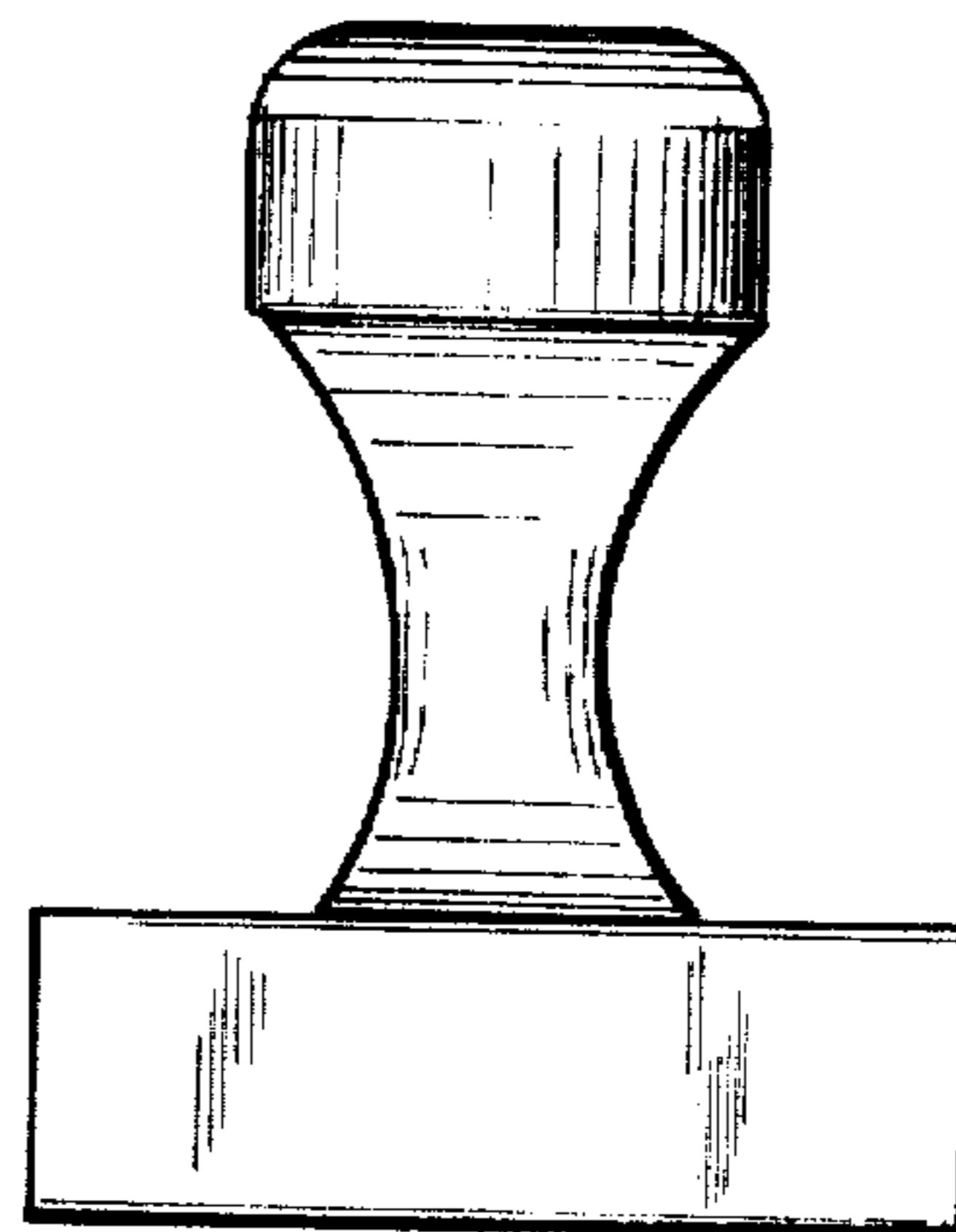

FIG. 5

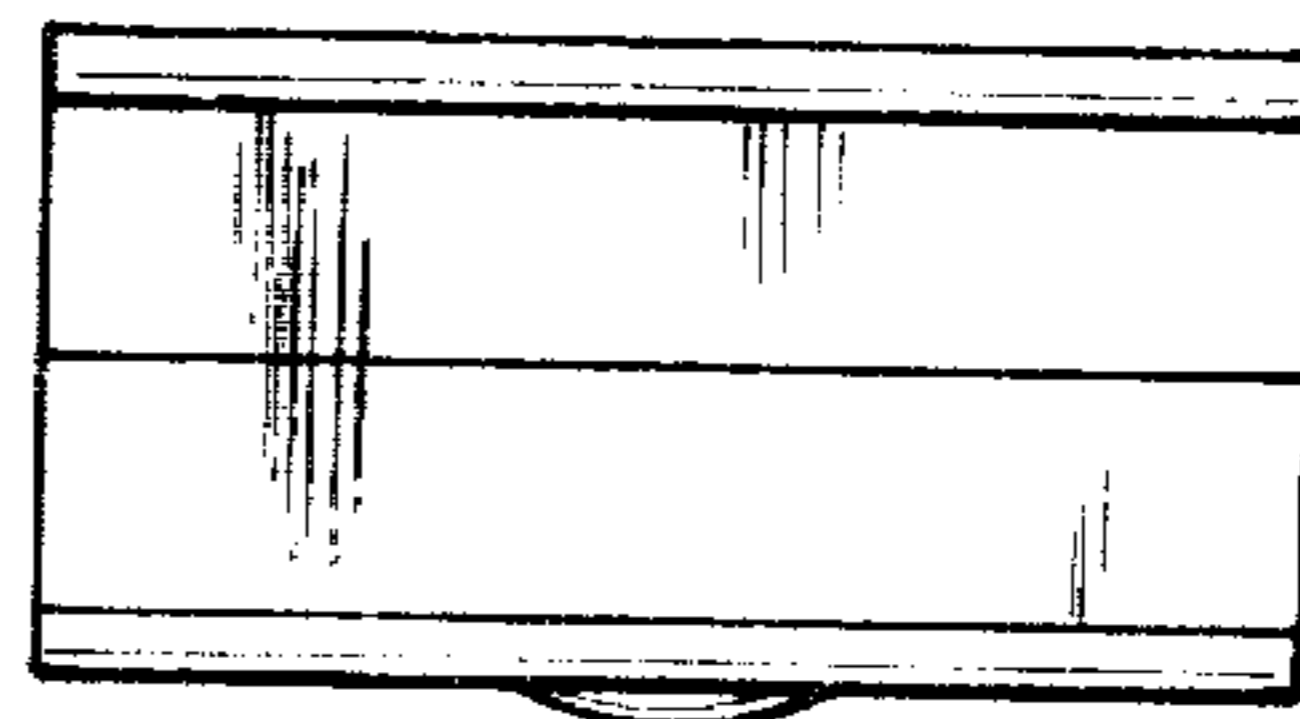

FIG. 6