

[54] **TIE DOWN BRACKET FOR LUGGAGE RACK**

[75] **Inventors:** Ben C. Kowalski, Troy; Daniel J. Kowalski, Ortonville; Douglas J. Ferguson, Davisburg, all of Mich.

[73] **Assignee:** Four Star Corporation, Troy, Mich.

[**] **Term:** 14 Years

[21] **Appl. No.:** 945,257

[22] **Filed:** Sep. 25, 1978

[51] **Int. Cl.** D12-16

[52] **U.S. Cl.** D12/157; D8/383

[58] **Field of Search** D12/157; D8/382, 383, D8/356; 224/310, 321, 323-326, 329, 331, 315; 248/499, 500; 24/265 CD

[56]

References Cited

U.S. PATENT DOCUMENTS

4,132,335 1/1979 Ingram D8/382

Primary Examiner—James M. Gandy
Attorney, Agent, or Firm—Reising, Ethington, Barnard, Perry & Brooks

[57]

CLAIM

The ornamental design for a tie down bracket for luggage rack, as shown and described.

DESCRIPTION

FIG. 1 is a front elevational view of a tie down bracket for luggage rack showing our new design; FIG. 2 is a side elevational view thereof; FIG. 3 is a rear elevational view thereof; FIG. 4 is a side elevational view thereof from the side opposite that of FIG. 2; FIG. 5 is a top plan view thereof, and FIG. 6 is a bottom plan view thereof.

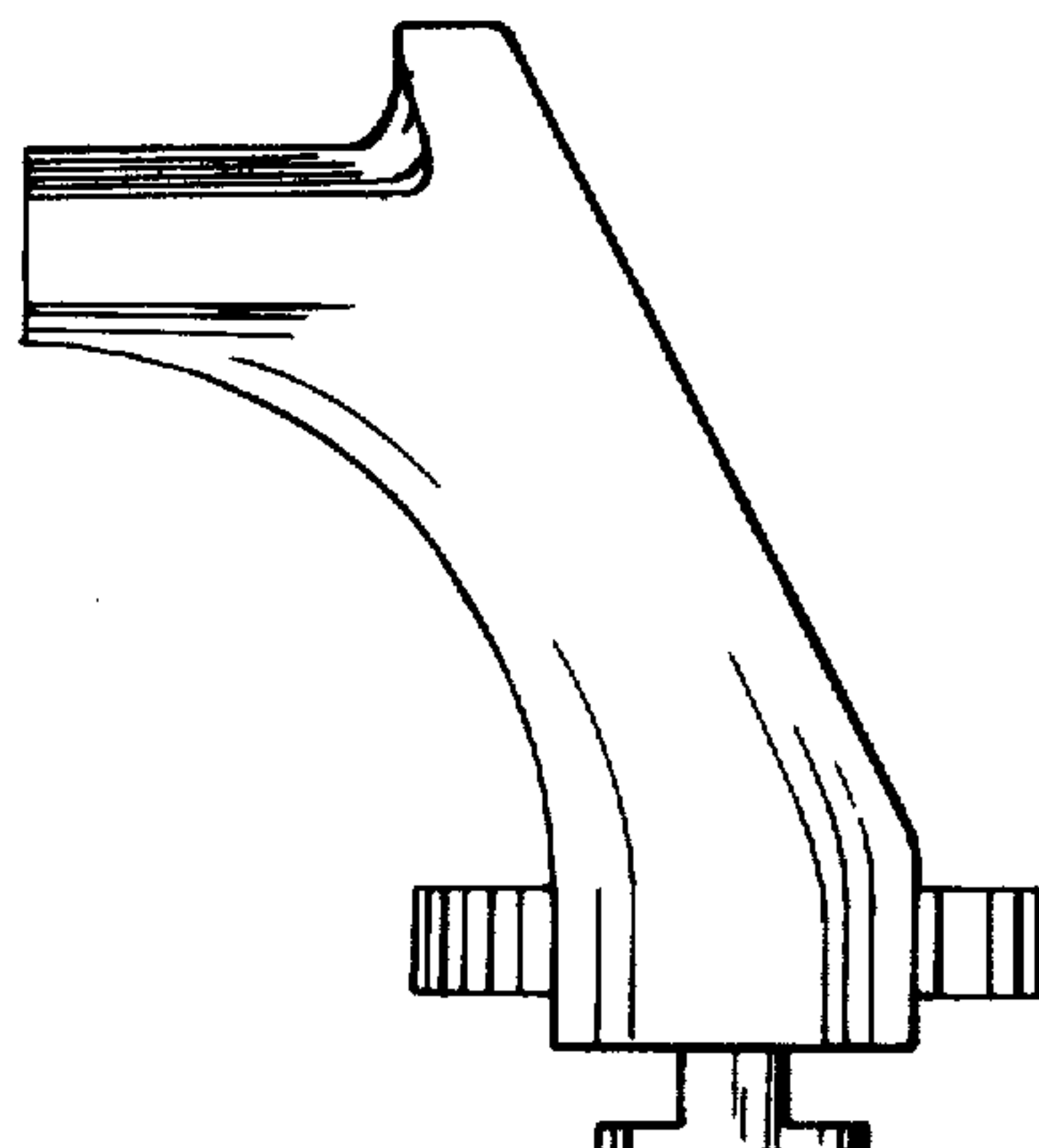
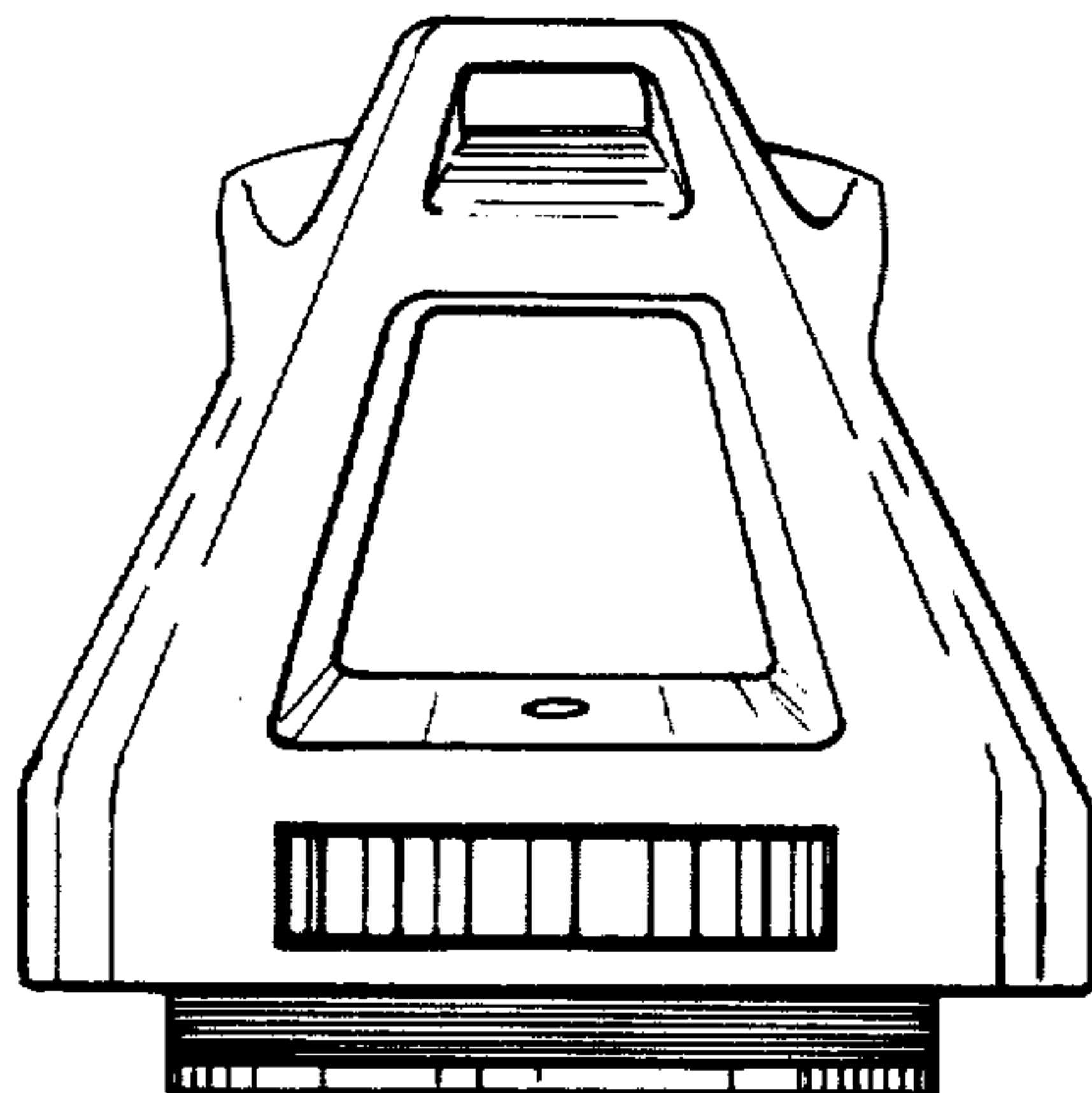

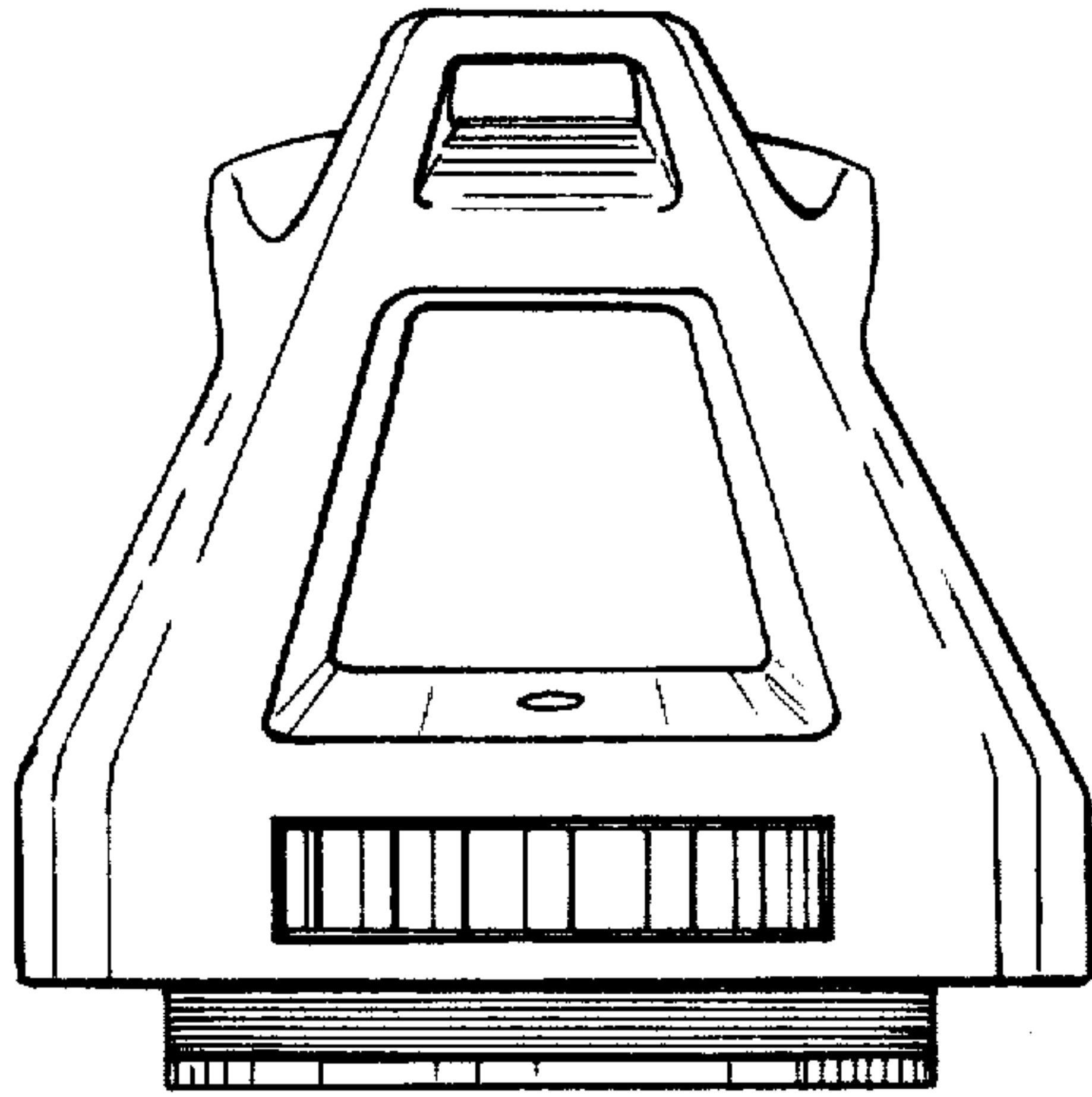

FIG-1

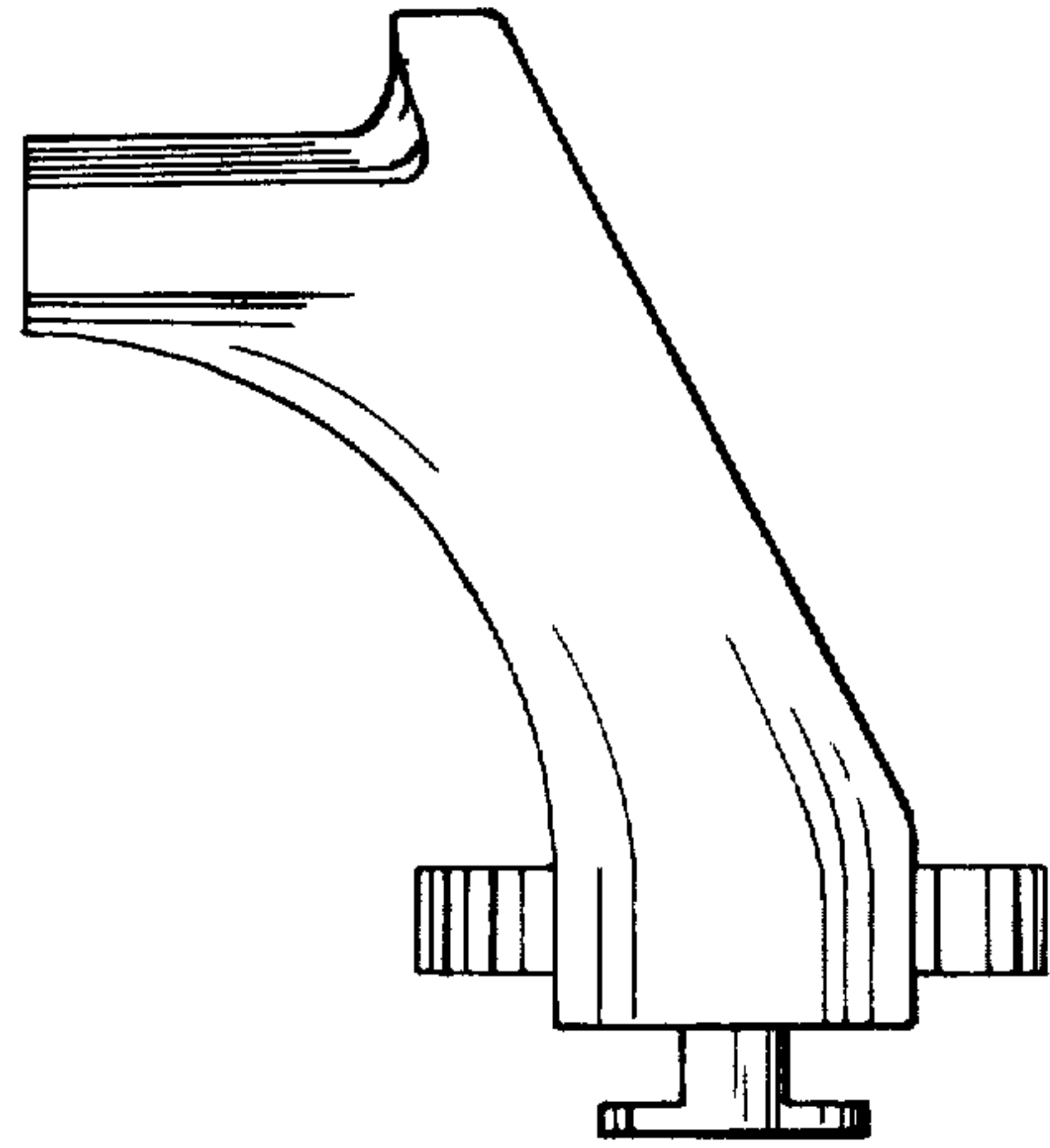

FIG-2

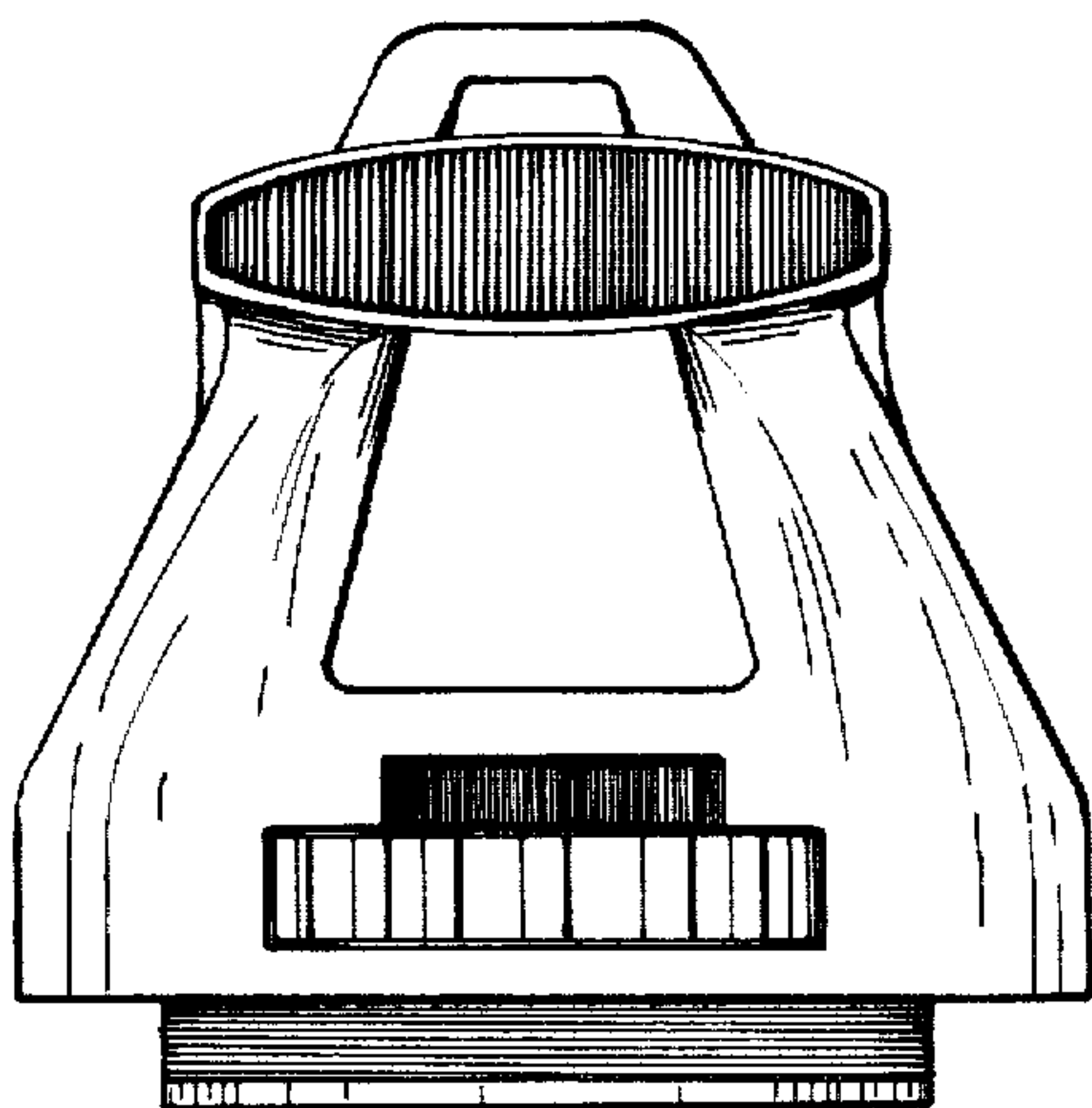

FIG-3

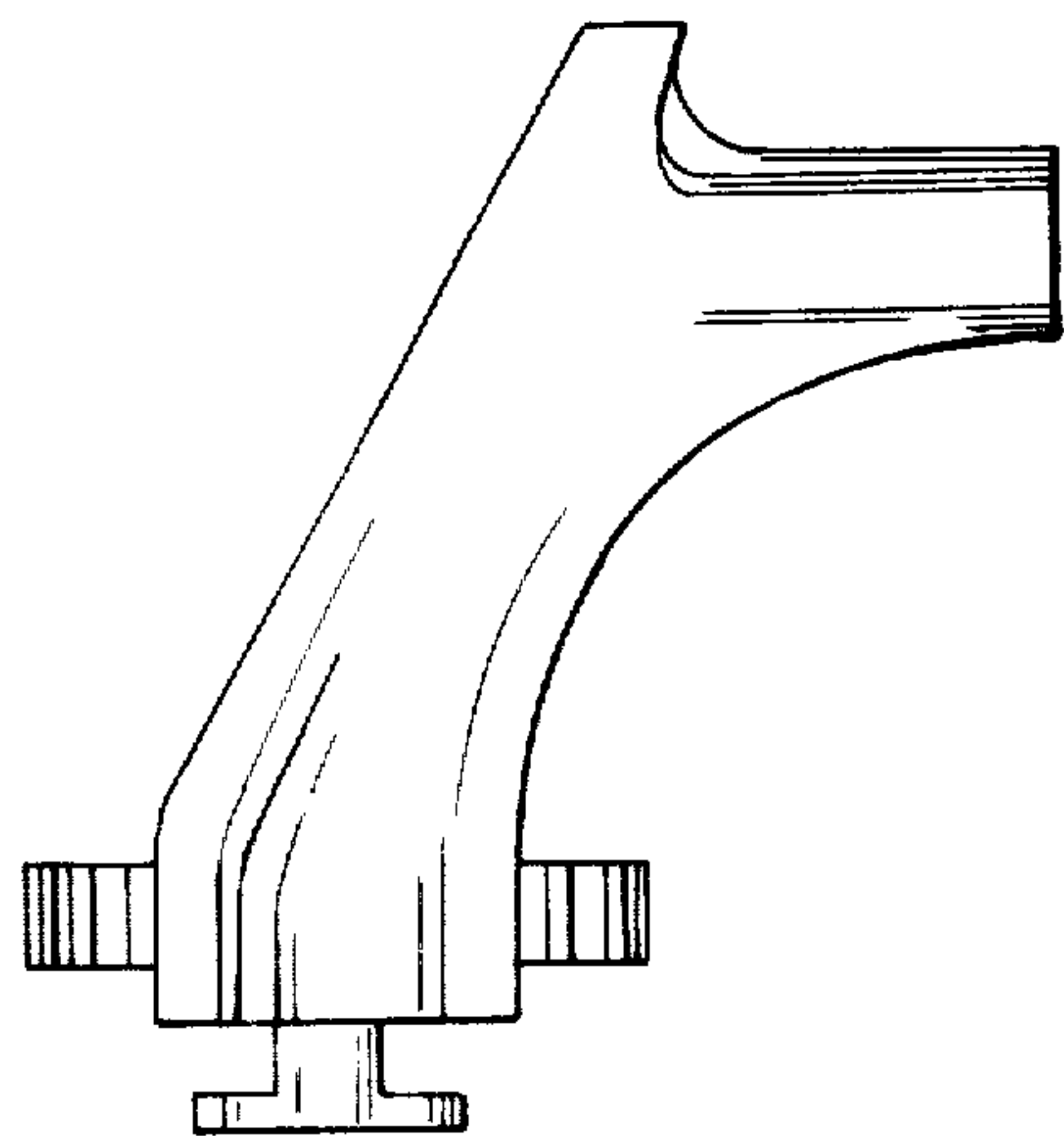

FIG-4

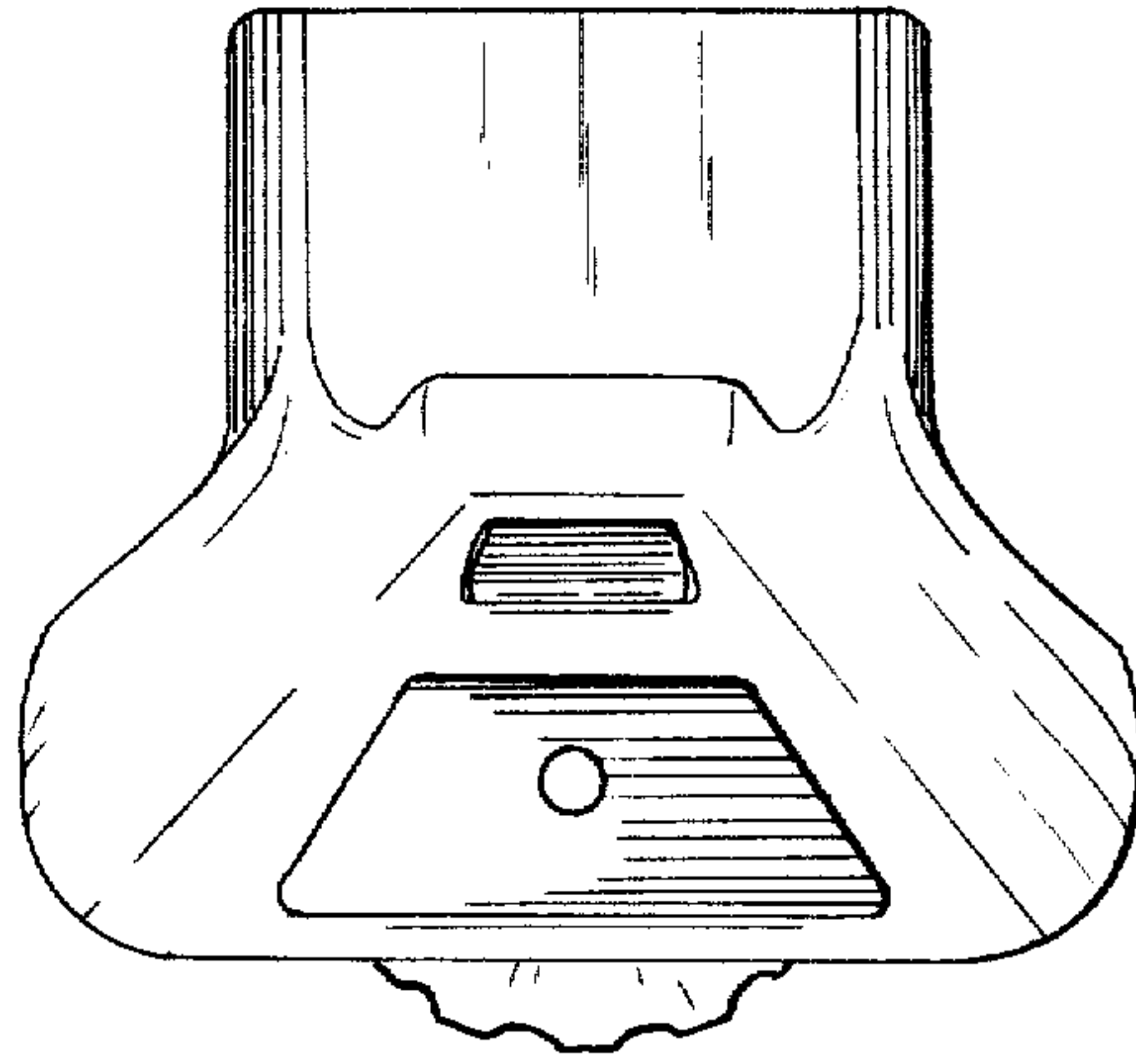

FIG-5

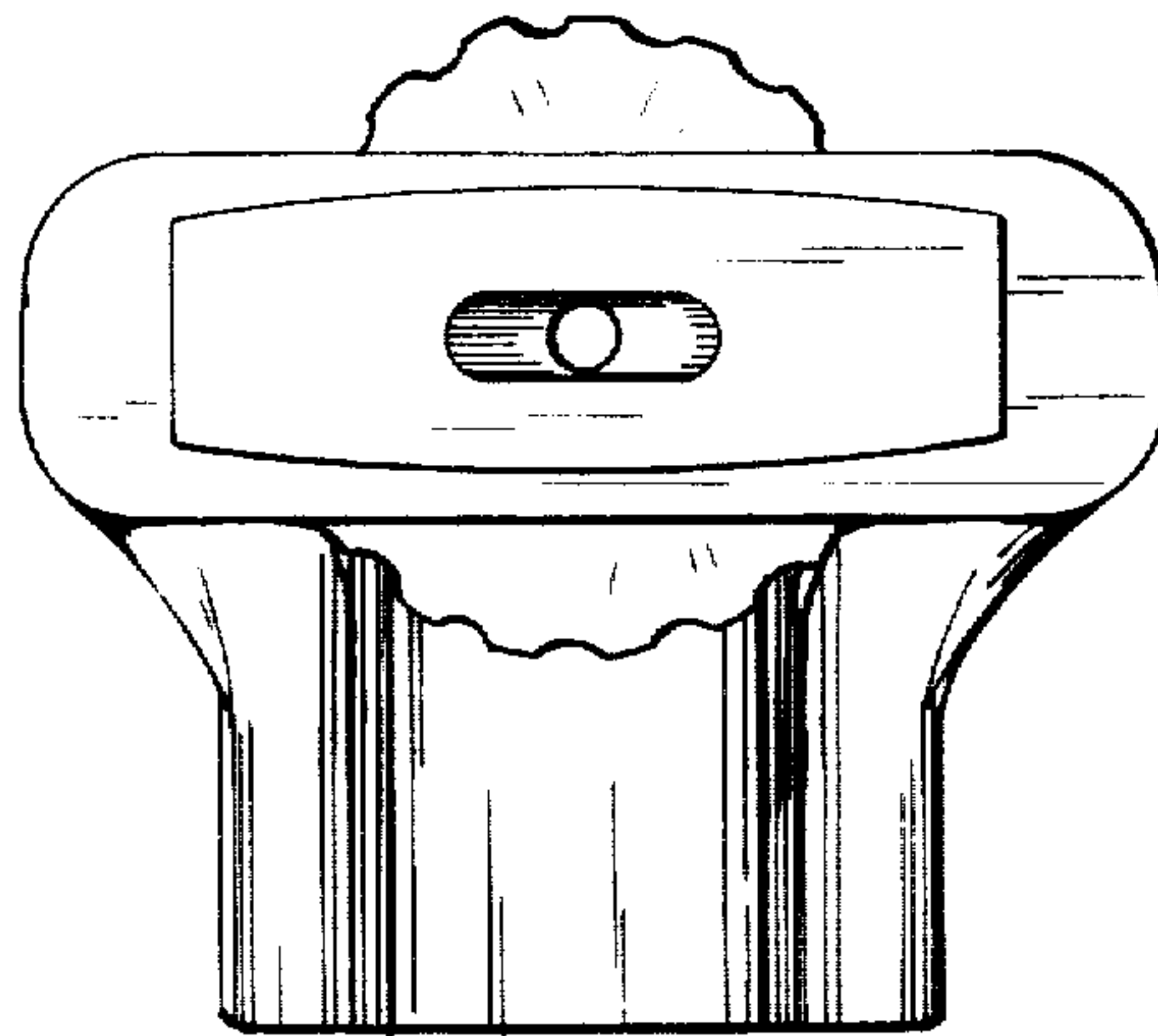

FIG-6