

[54] BOTTLE

[76] Inventor: Diane C. Balich, Sturges Rd., Henderson, Auckland, New Zealand

[**] Term: 14 Years

[21] Appl. No.: 91,202

[22] Filed: Nov. 7, 1979

[30] Foreign Application Priority Data

May 29, 1979 [NZ] New Zealand 16078

[51] Int. Cl. D9-01

[52] U.S. Cl. D9/311

[58] Field of Search D9/310, 311, 316, 317, D9/318; 229/8

[56] References Cited

U.S. PATENT DOCUMENTS

D. 102,033 11/1936 Mann D9/311

D. 116,573 9/1939 Oya D9/316
D. 185,247 5/1959 Taran D9/311
D. 195,902 8/1963 Kocab D9/316

Primary Examiner—Robert C. Spangler
Attorney, Agent, or Firm—Holman & Stern

[57] CLAIM

The ornamental design for a bottle, as shown and described.

DESCRIPTION

FIG. 1 is an elevational view of a bottle showing my new design, the opposite side being substantially the same in appearance;

FIG. 2 is an elevational view looking from the right of FIG. 1, the opposite side being substantially the same in appearance;

FIG. 3 is a top plan view thereof; and

FIG. 4 is a vertical sectional view taken along lines A-B of FIGS. 1-3.

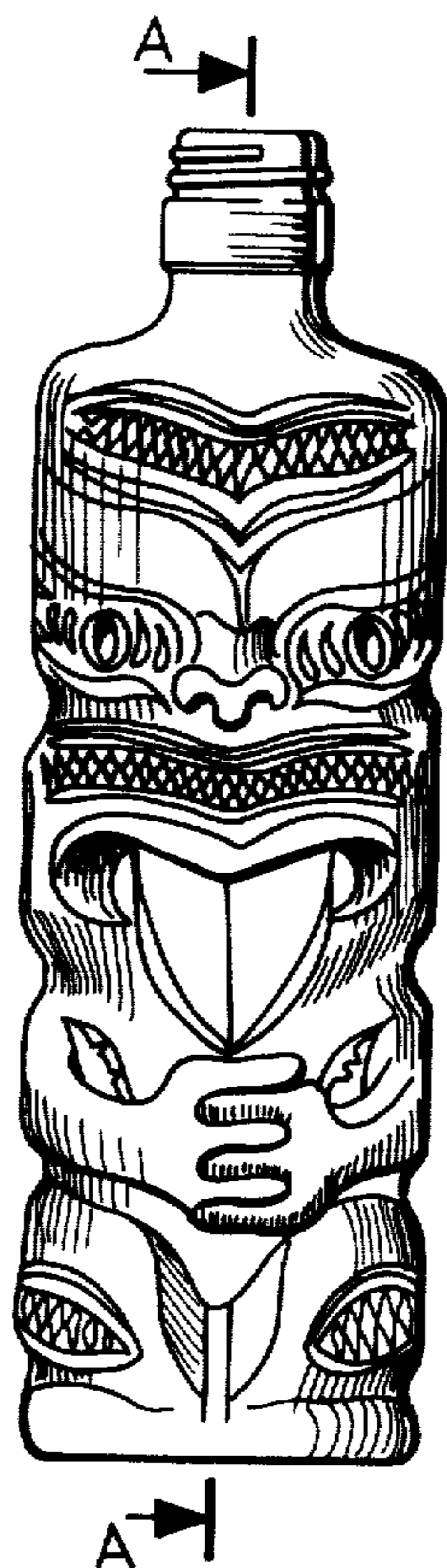

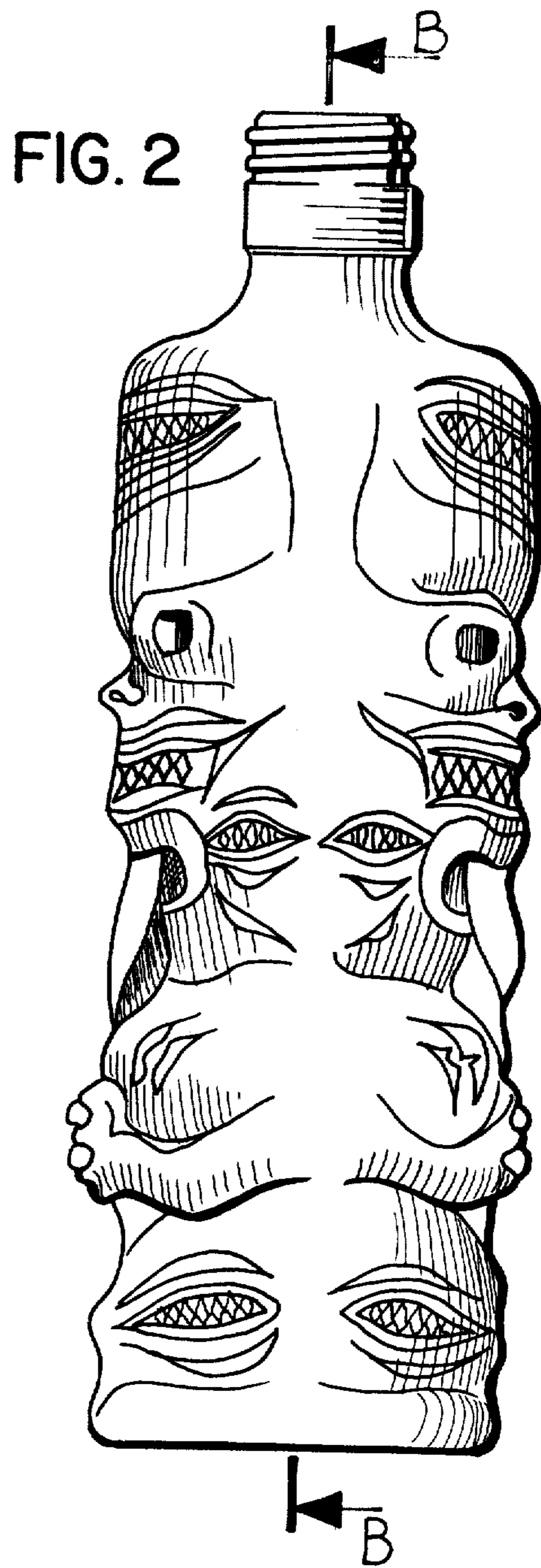

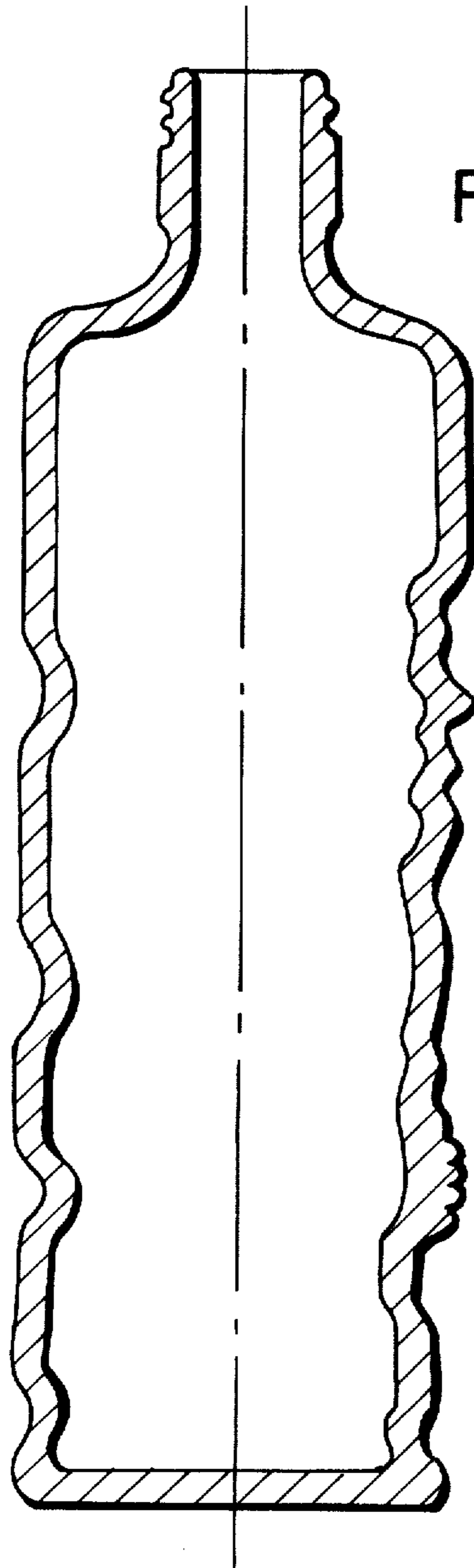

FIG. 4

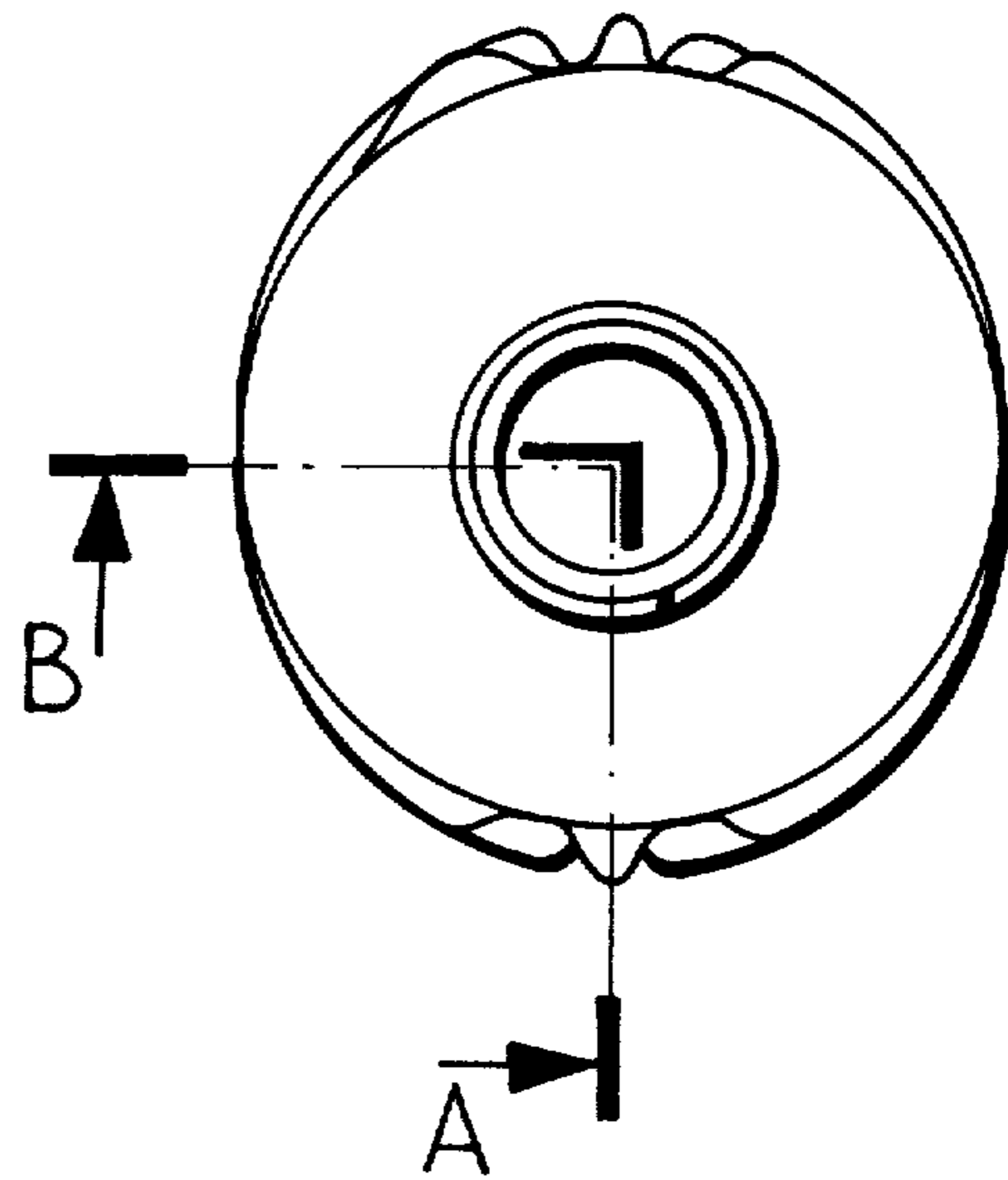

FIG. 3