

- [54] **TIE DOWN BRACKET FOR A LUGGAGE RACK RACK**
- [75] Inventor: **Charles E. Ingram, Warren, Mich.**
- [73] Assignee: **Four Star Corporation, Troy, Mich.**
- [**] Term: **14 Years**
- [21] Appl. No.: **945,256**
- [22] Filed: **Sep. 25, 1978**
- [51] Int. Cl. **D12-16**
- [52] U.S. Cl. **D12/157; D8/382**
- [58] Field of Search **D12/157; D8/382, 383, D8/356; 224/310, 321, 323, 329, 324-326, 331, 315; 248/499, 500; 24/265 CD**

- [56] **References Cited**
- U.S. PATENT DOCUMENTS**
- 4,132,335 1/1979 Ingram **D8/382**

Primary Examiner—James M. Gandy
Attorney, Agent, or Firm—Reising, Ethington, Barnard, Perry & Brooks

[57] **CLAIM**

The ornamental design for a tie down bracket for a luggage rack, as shown and described.

DESCRIPTION

FIG. 1 is a perspective, frontal view of a tie down bracket for a luggage rack showing my new design; FIG. 2 is a top plan view thereof on a reduced scale; FIG. 3 is a bottom plan view thereof on a reduced scale; FIG. 4 is a front elevational view thereof on a reduced scale; FIG. 5 is a side elevational view thereof on a reduced scale; FIG. 6 is a rear elevational view thereof on a reduced scale; and FIG. 7 is a side elevational view thereof on a reduced scale as seen from the side opposite that of FIG. 5.

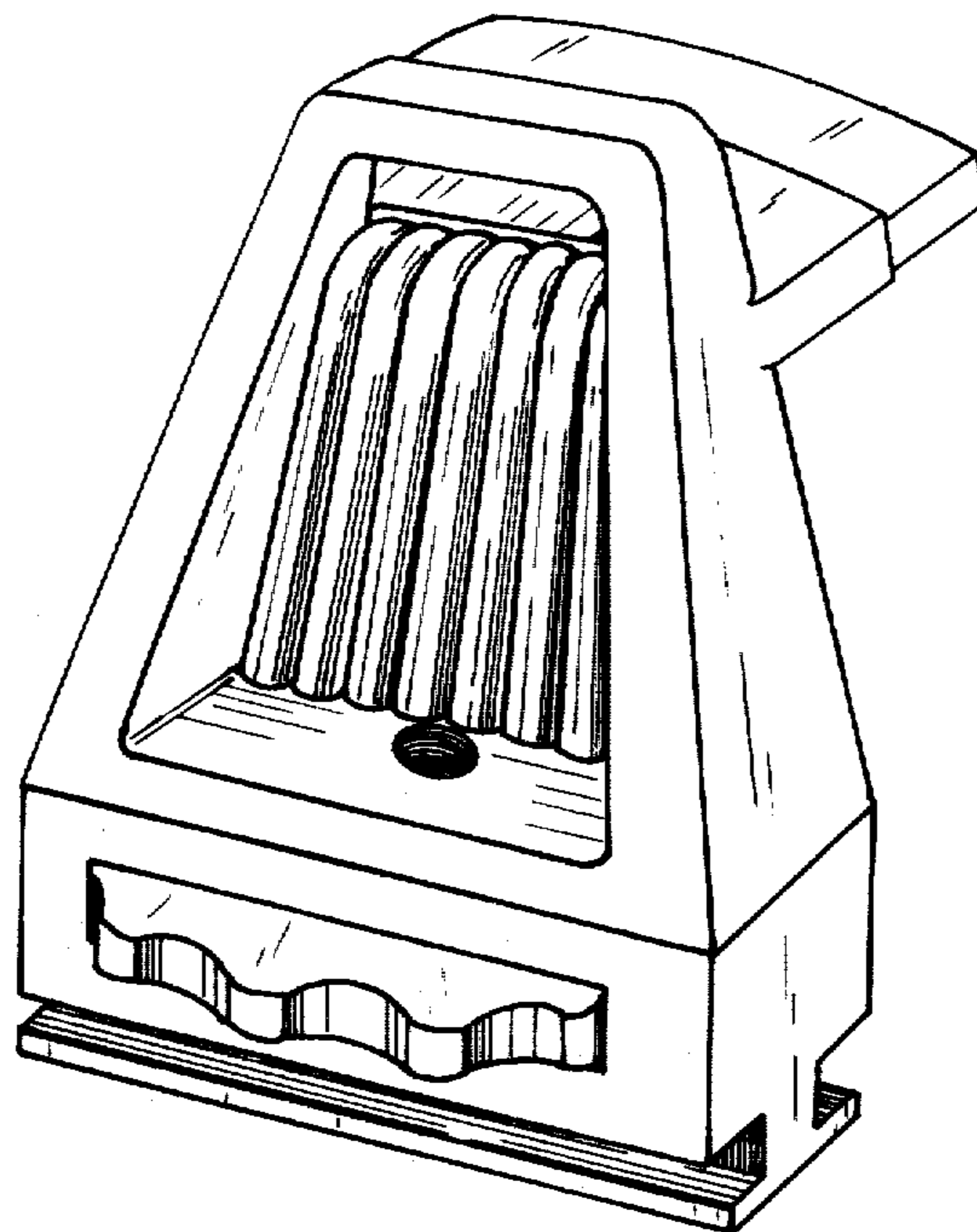

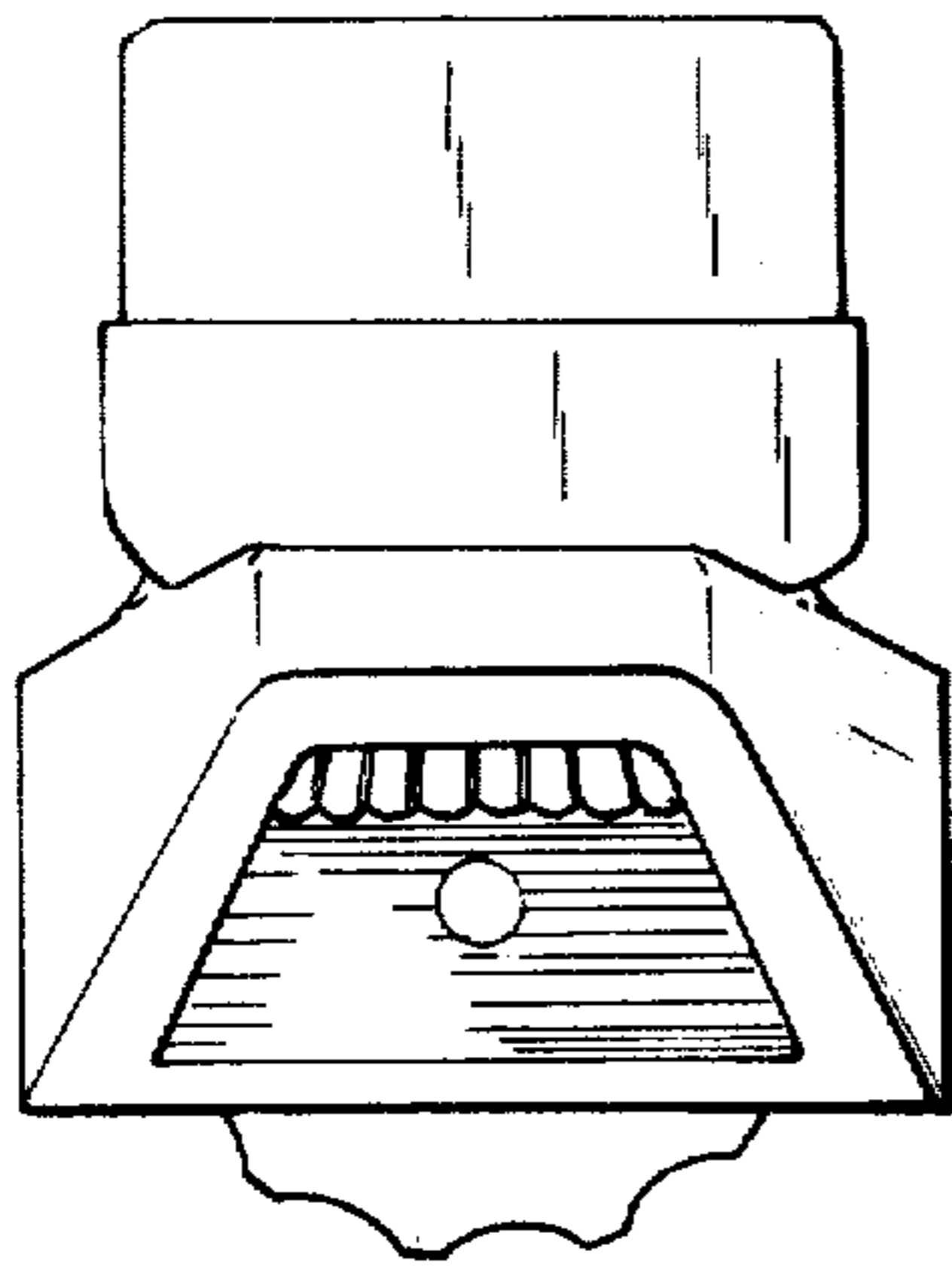

FIG-2

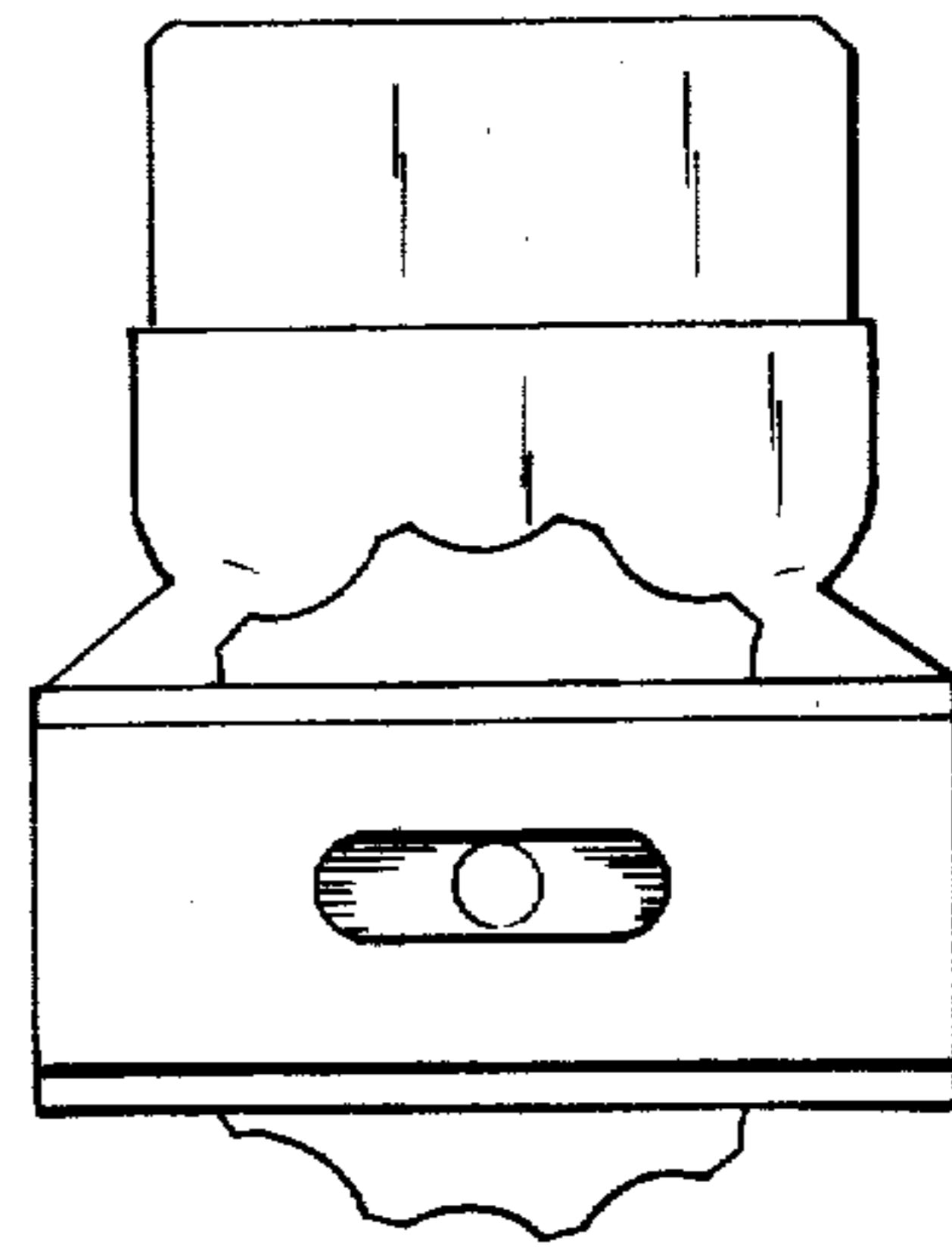
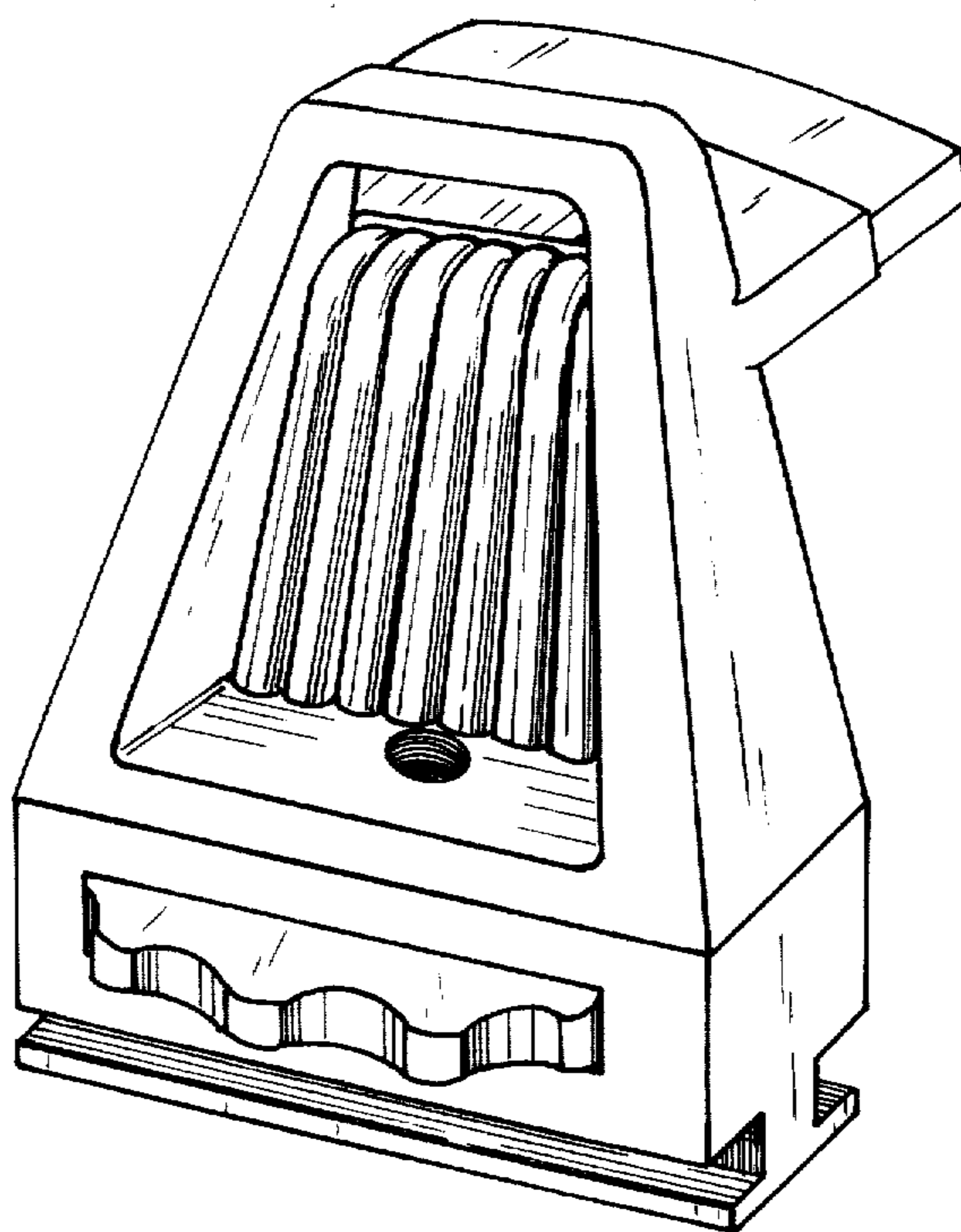

FIG-3

FIG-1



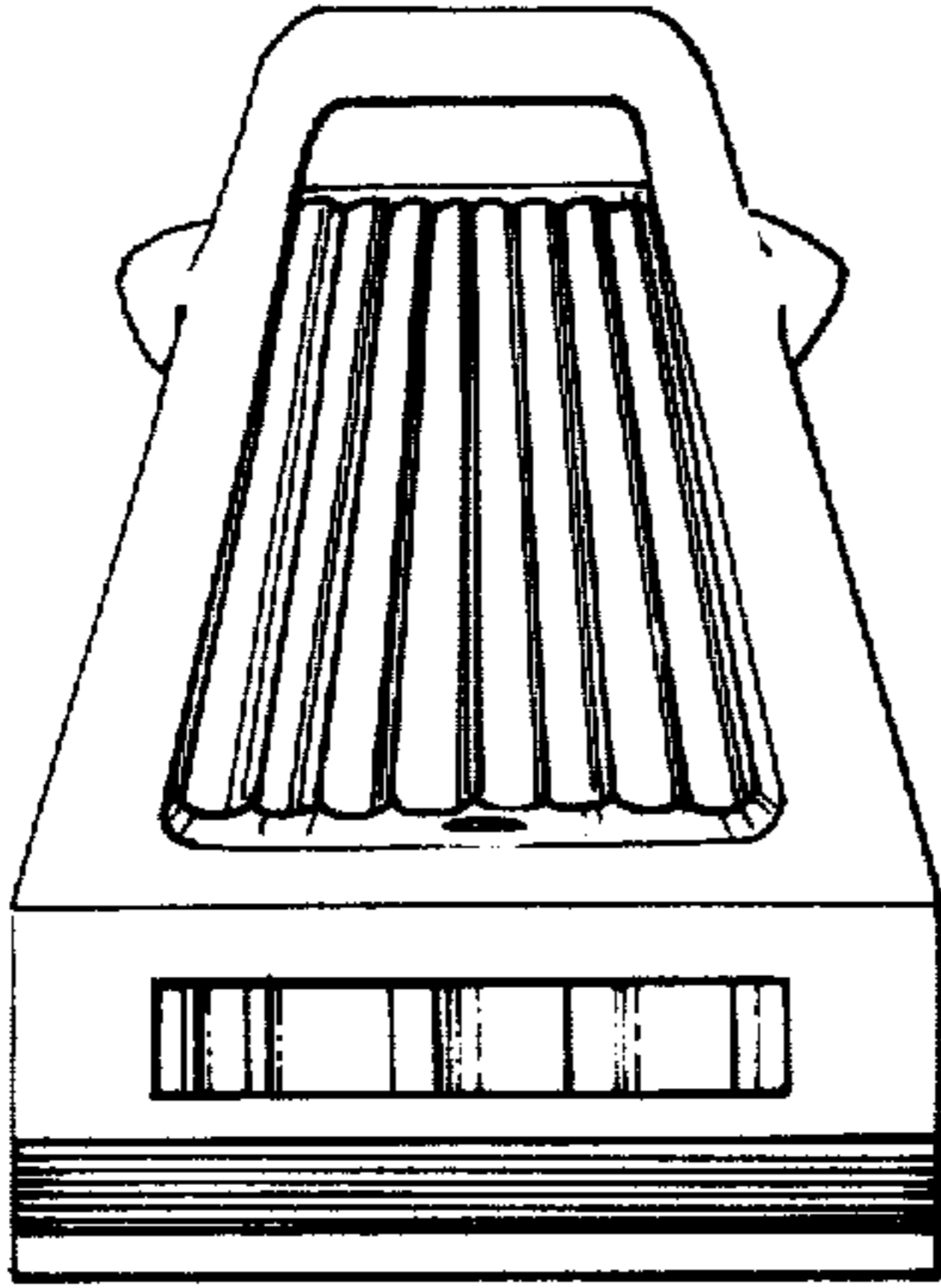

FIG-4

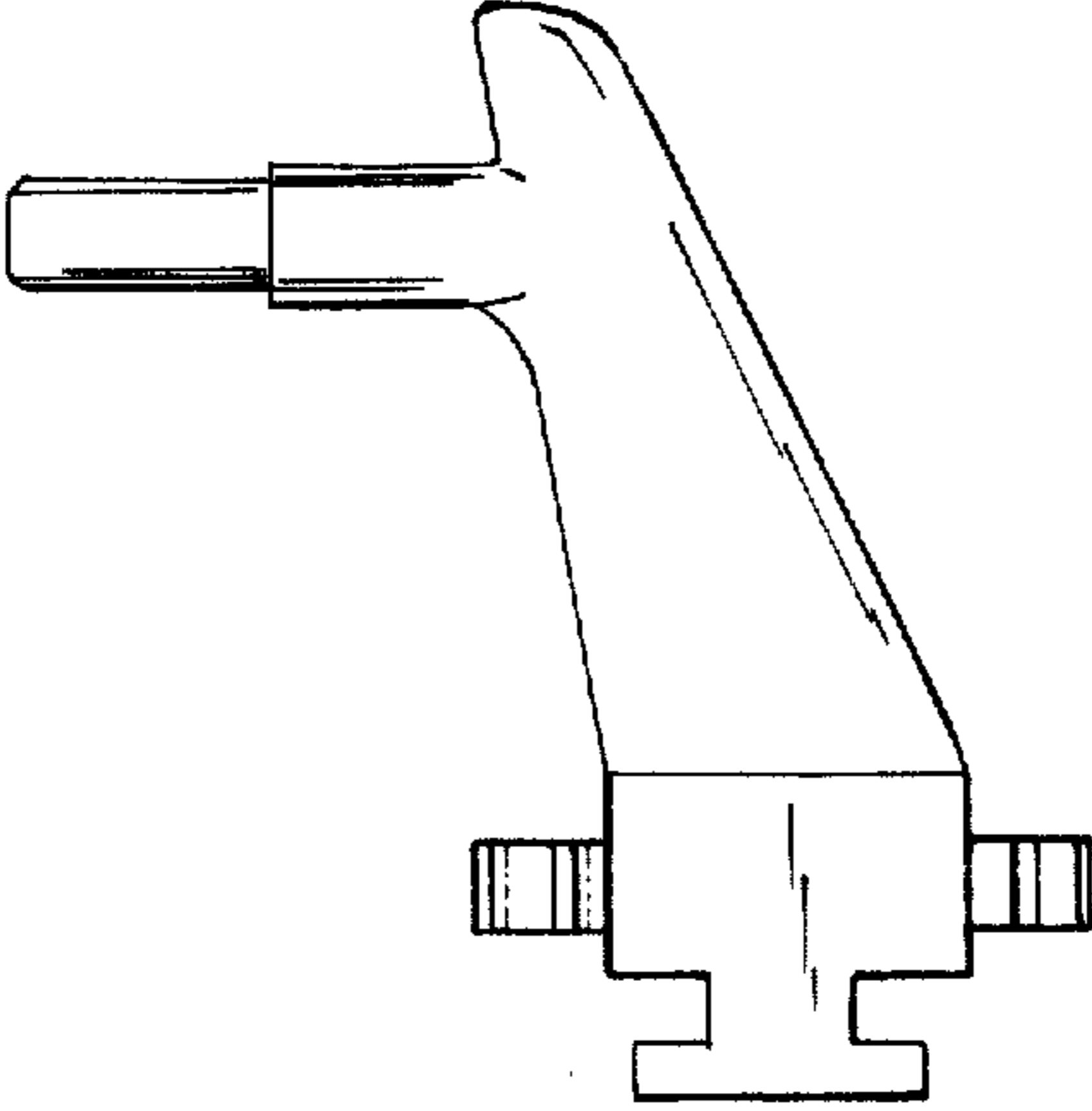

FIG-5

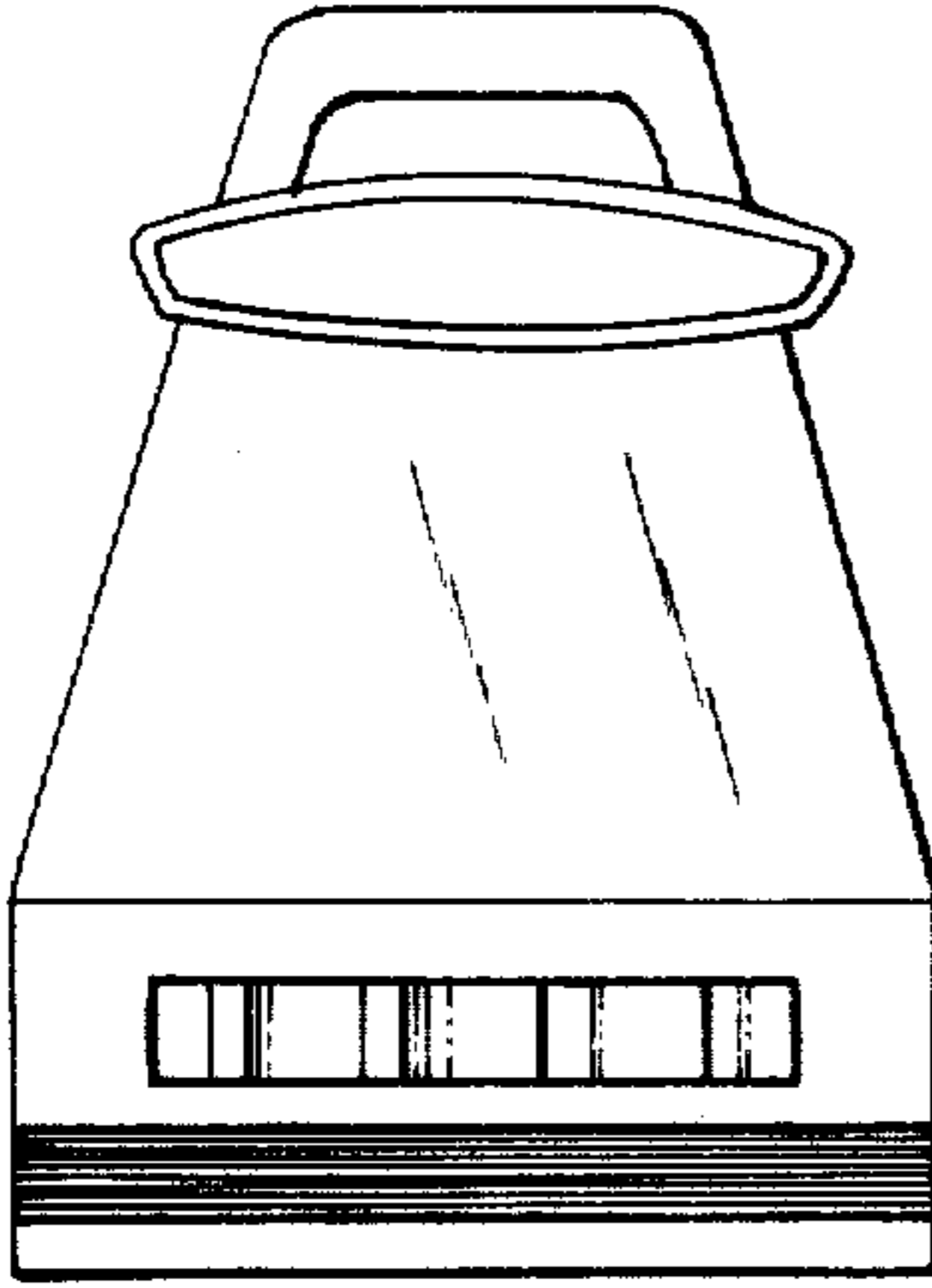

FIG-6

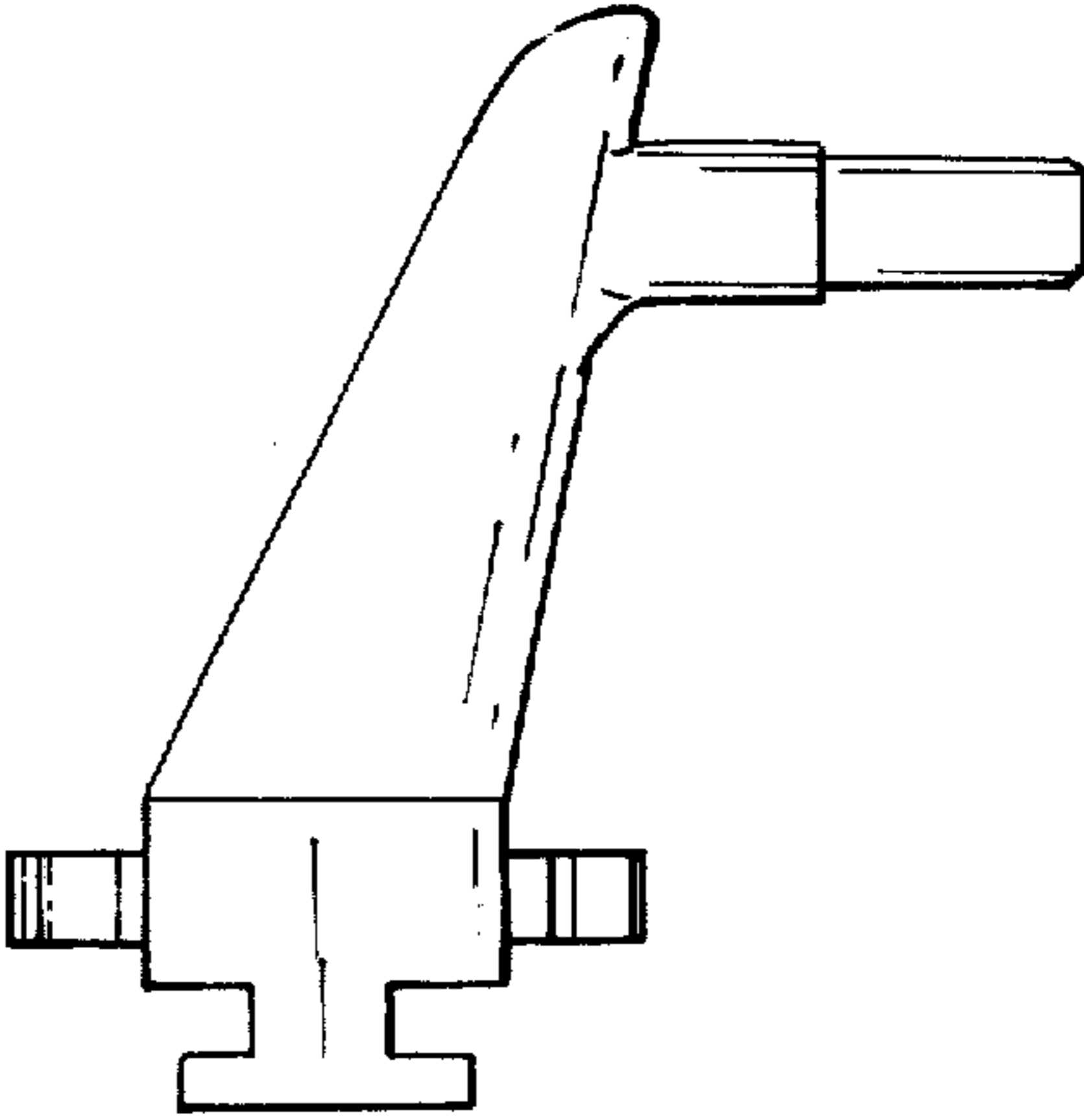

FIG-7