

[54] POWER DRIVEN SKI VEHICLE

[75] Inventors: Charles Stewart, Bourbonnais;
Richard W. Condon, Frankfort, both
of Ill.

[73] Assignee: Roper Corporation, Kankakee, Ill.

[**] Term: 14 Years

[21] Appl. No.: 947,247

[22] Filed: Sep. 29, 1978

[51] Int. Cl. D12-14

[52] U.S. Cl. D12/7

[58] Field of Search D12/7, 9, 10; 180/182,
180/181, 183

[56] References Cited

U.S. PATENT DOCUMENTS

D. 225,106 11/1972 Majjala D12/7
3,814,198 6/1974 Seiler 180/183

Primary Examiner—James M. Gandy
Attorney, Agent, or Firm—Fitch, Even, Tabin, Flannery
& Welsh

[57] CLAIM

The ornamental design for a power driven ski vehicle,
substantially as shown and described.

DESCRIPTION

FIG. 1 is a perspective view of a power driven ski vehi-
cle showing our new design;
FIG. 2 is a side elevational view thereof;
FIG. 3 is another side elevational view thereof showing
the side opposite of that shown in FIG. 2; and
FIG. 4 is a rear perspective view thereof.

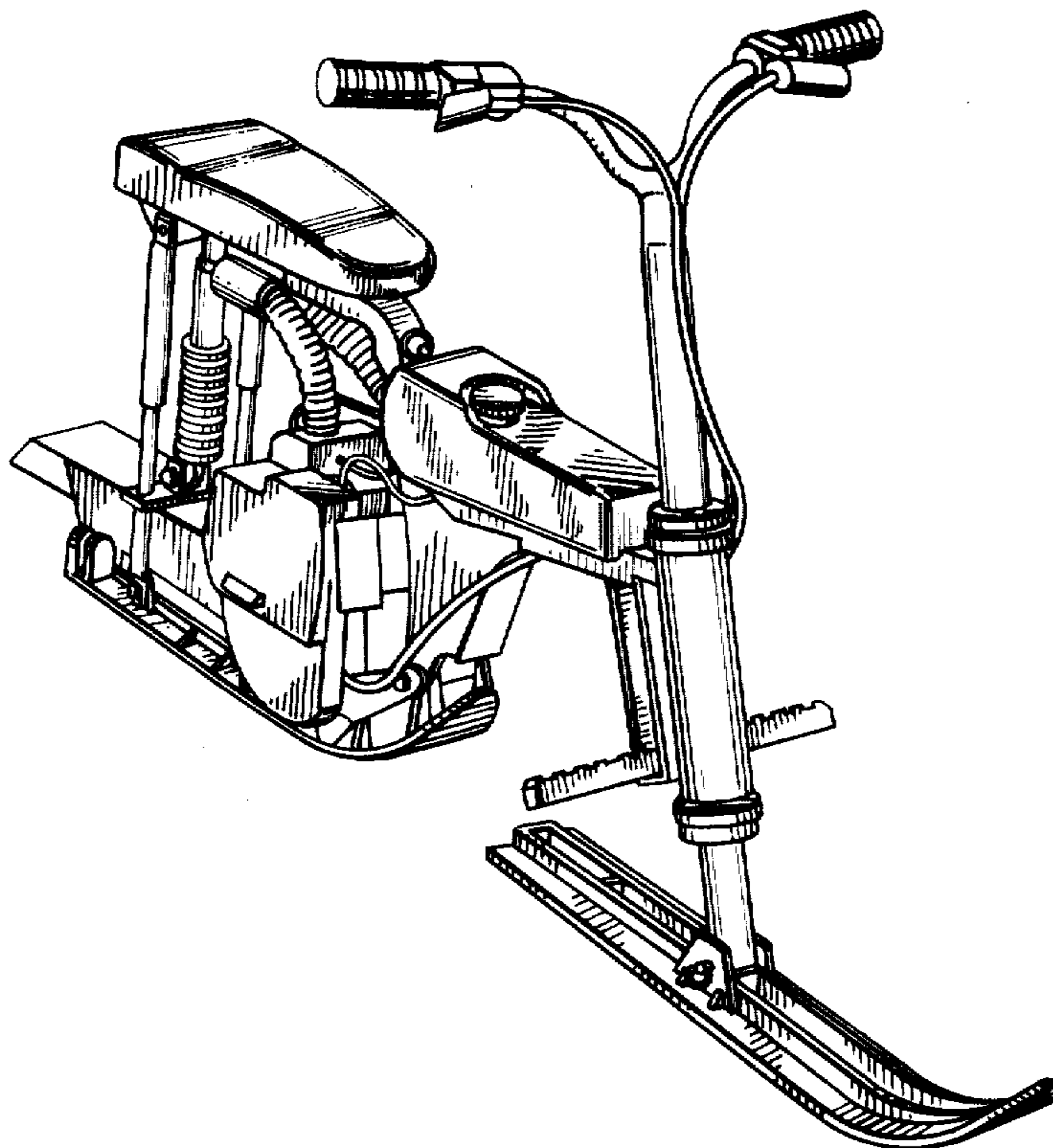

FIG. 1.

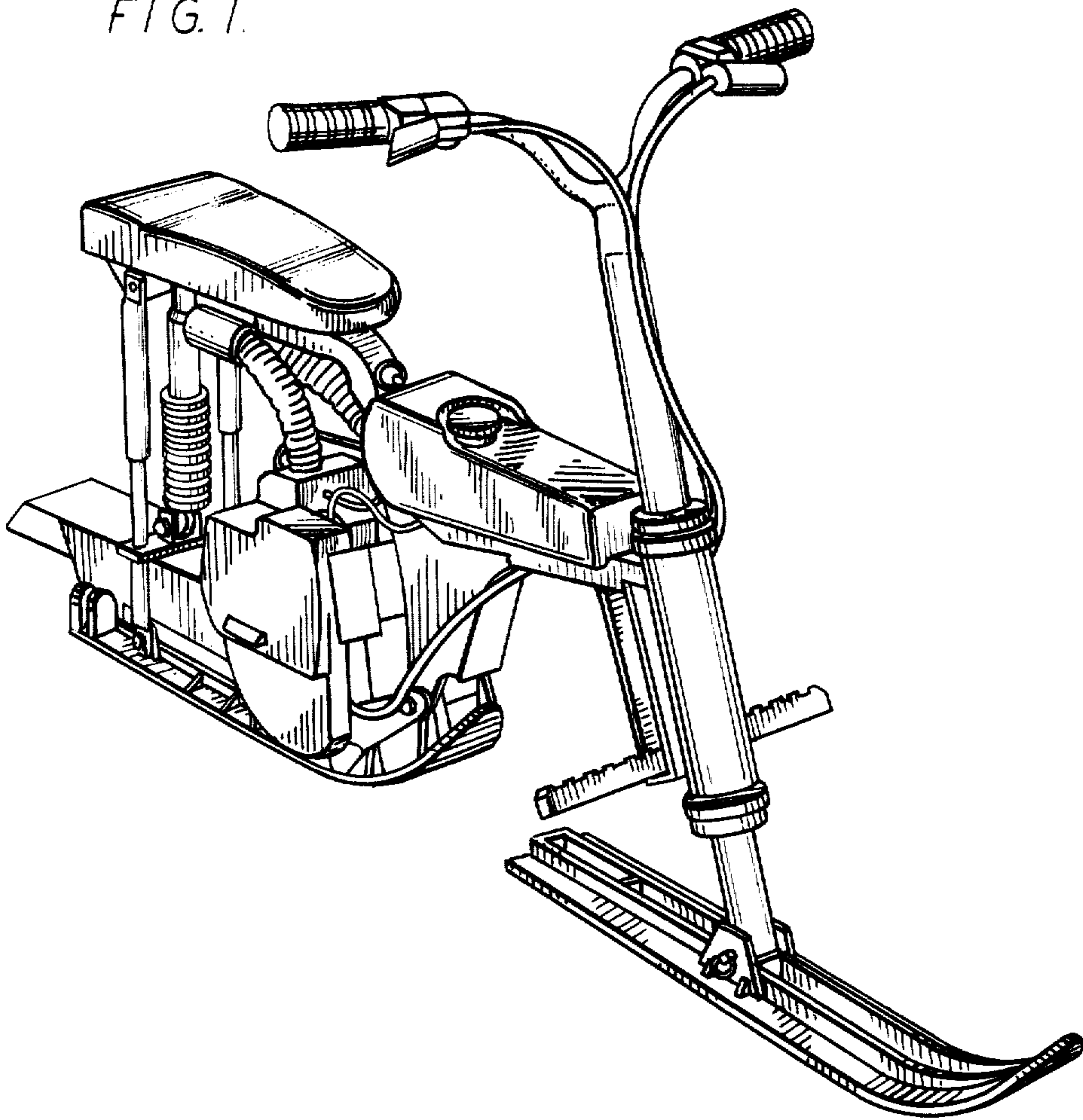

FIG. 2.

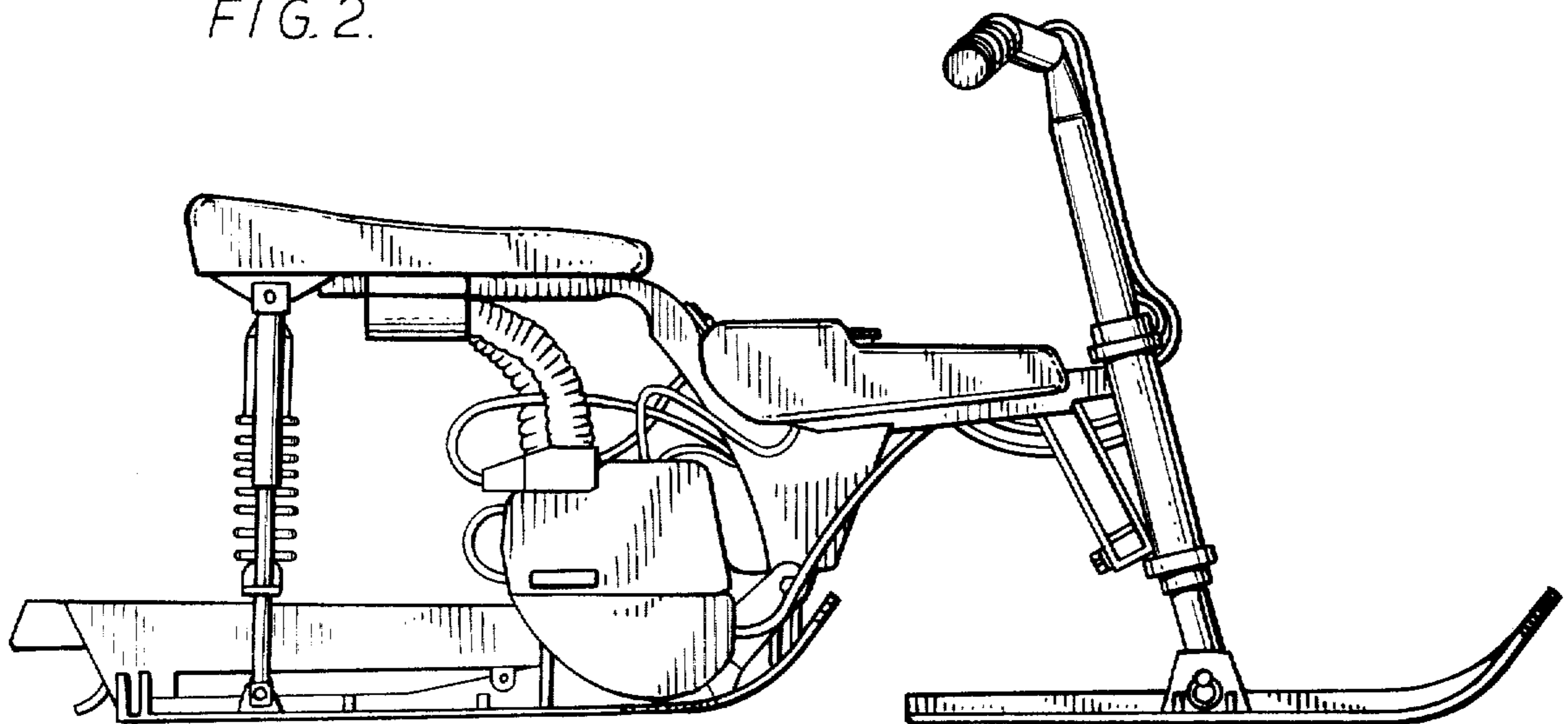

FIG. 3.

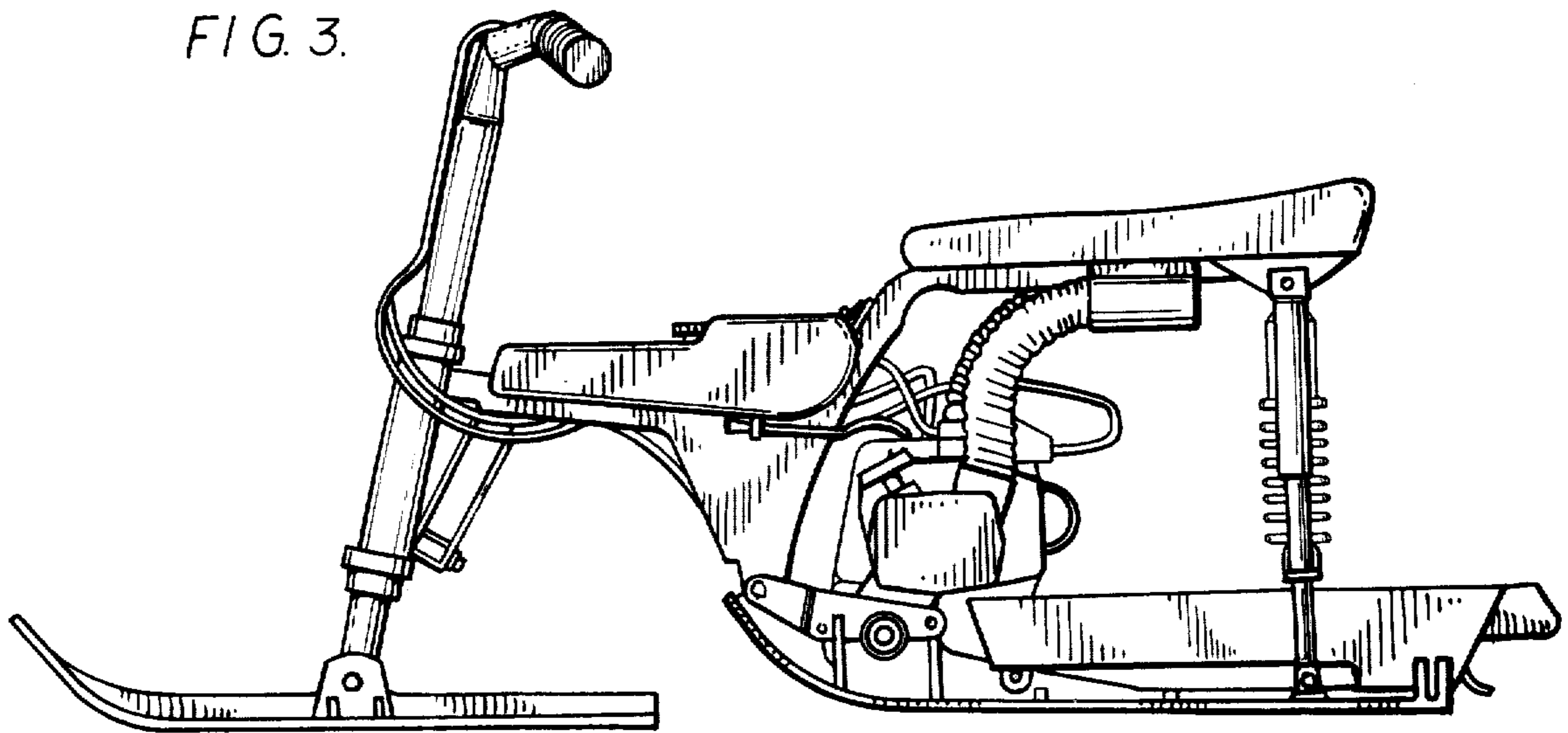

FIG. 4.

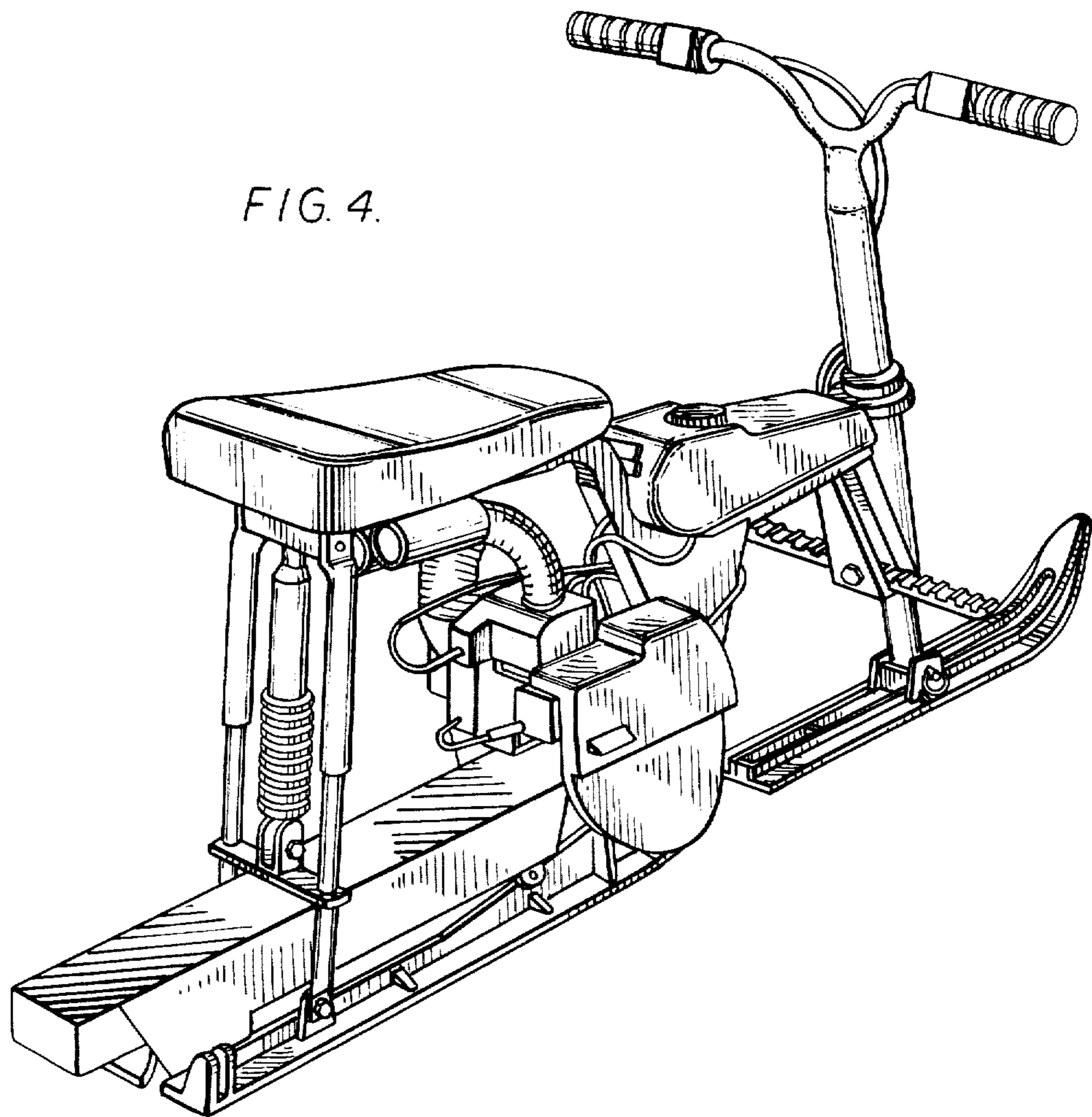

FIG. 5.

