

[54] **TOY RACING CAR**

[75] **Inventors:** Mel Appel, Nine Nottingham Rd., Livingston, N.J. 07039; George Kress, Scotch Plains, N.J.

[73] **Assignee:** Mel Appel, Livingston, N.J.

[\*\*] **Term:** 14 Years

[21] **Appl. No.:** 240,783

[22] **Filed:** Mar. 5, 1981

[51] **Int. Cl.** ..... D21-01

[52] **U.S. Cl.** ..... D21/137

[58] **Field of Search** ..... D21/124, 128, 132, 134, D21/135-137, 140, 76, 79, 81; 46/103, 105, 201, 202, 204, 206, 210, 211, 212, 213; 280/87.01, 87.02 R

[56] **References Cited**

**U.S. PATENT DOCUMENTS**

- D. 246,613 12/1977 Ogawa ..... D21/137
- D. 255,810 7/1980 Bretschger ..... D21/137
- D. 261,912 11/1981 Breneman ..... D21/137

*Primary Examiner*—Charles A. Rademaker  
*Attorney, Agent, or Firm*—Lerner, David, Littenberg & Samuel

[57] **CLAIM**

The design for a toy racing car, substantially as shown and described.

**DESCRIPTION**

- FIG. 1 is a perspective view of a toy racing car showing our new design;
- FIG. 2 is a front elevational view thereof;
- FIG. 3 is a rear elevational view thereof;
- FIG. 4 is a left side elevational view thereof;
- FIG. 5 is a right side elevational view thereof;
- FIG. 6 is a top plan view thereof;
- FIG. 7 is a bottom plan view thereof.

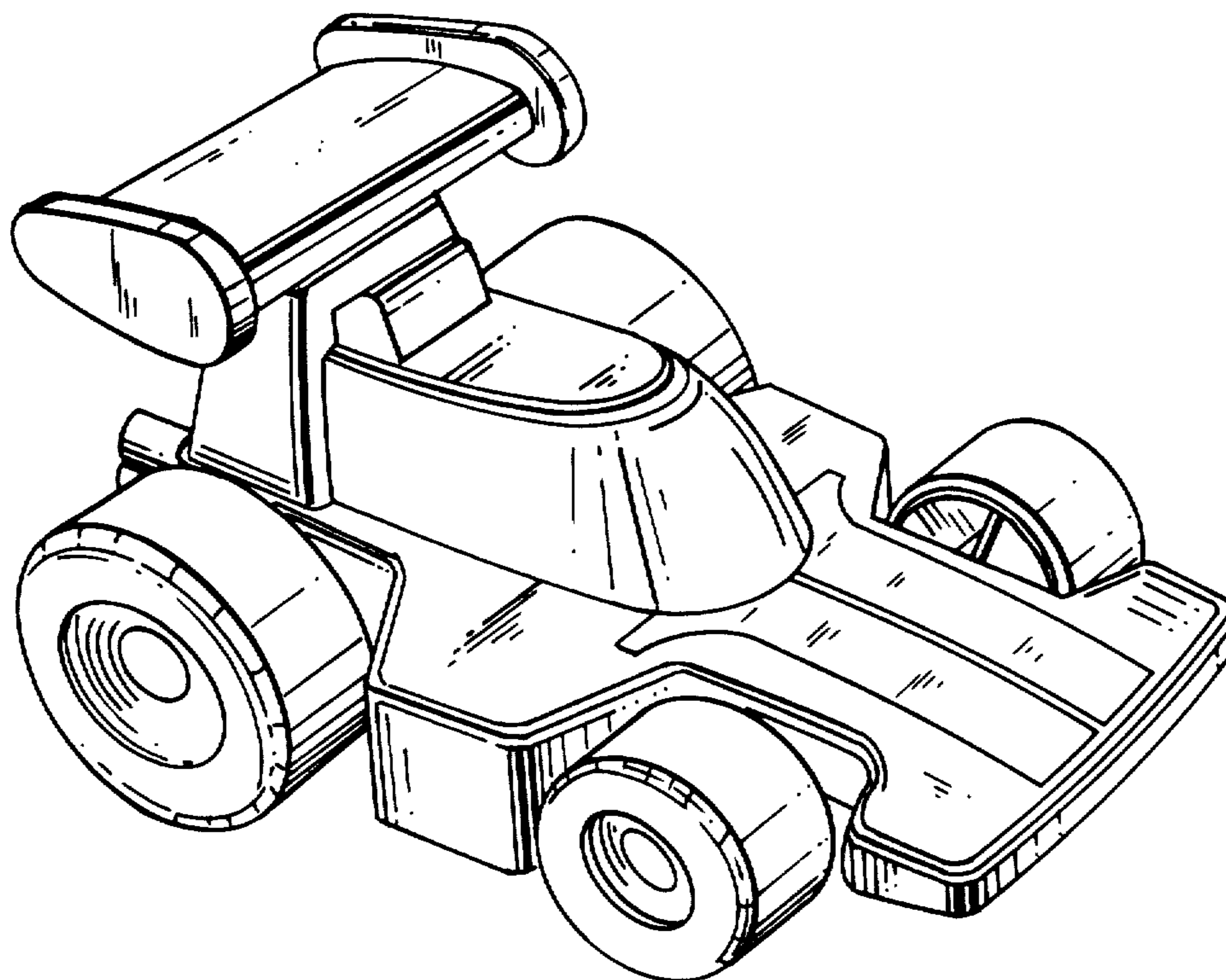

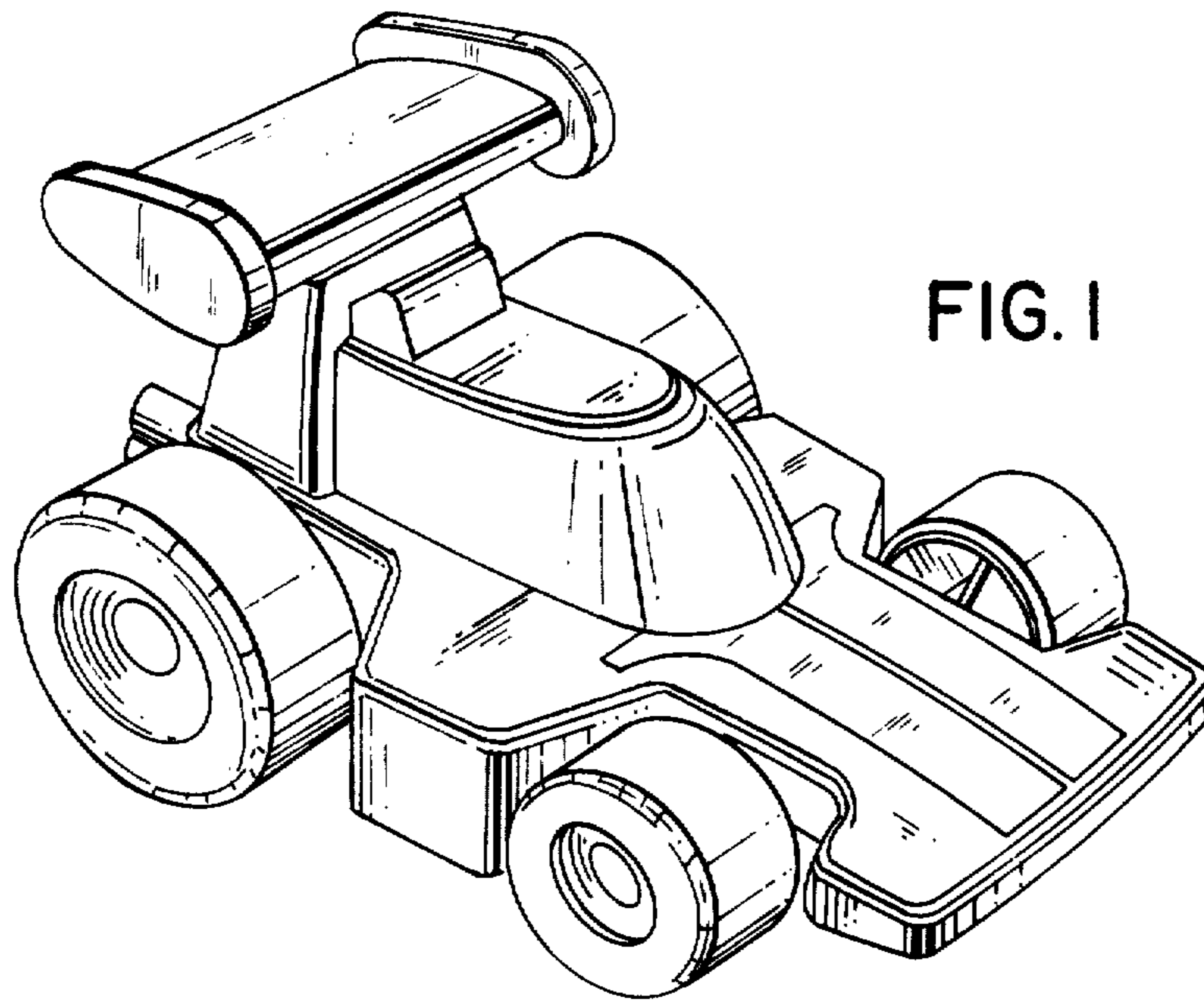

FIG. 1

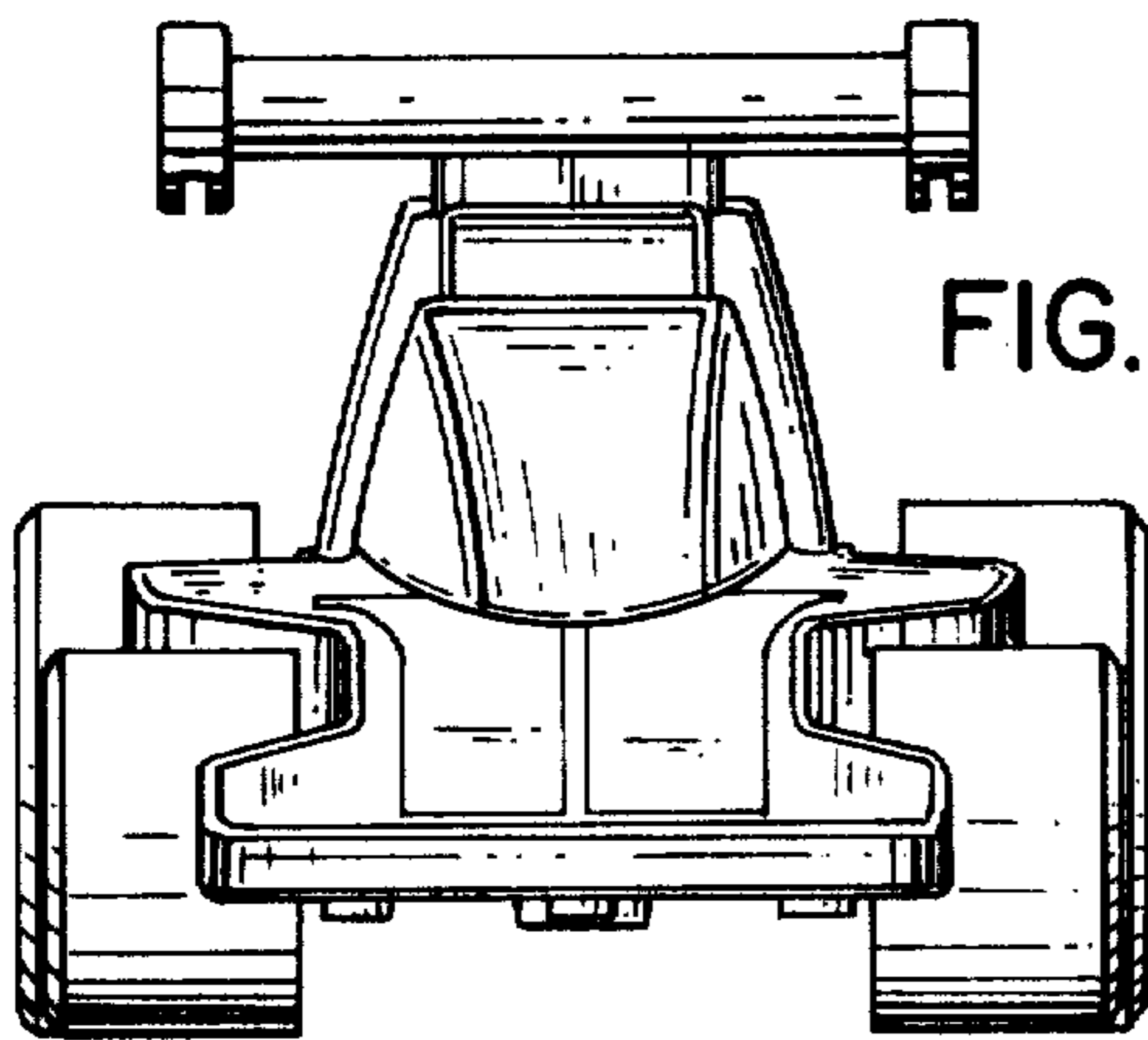

FIG. 2

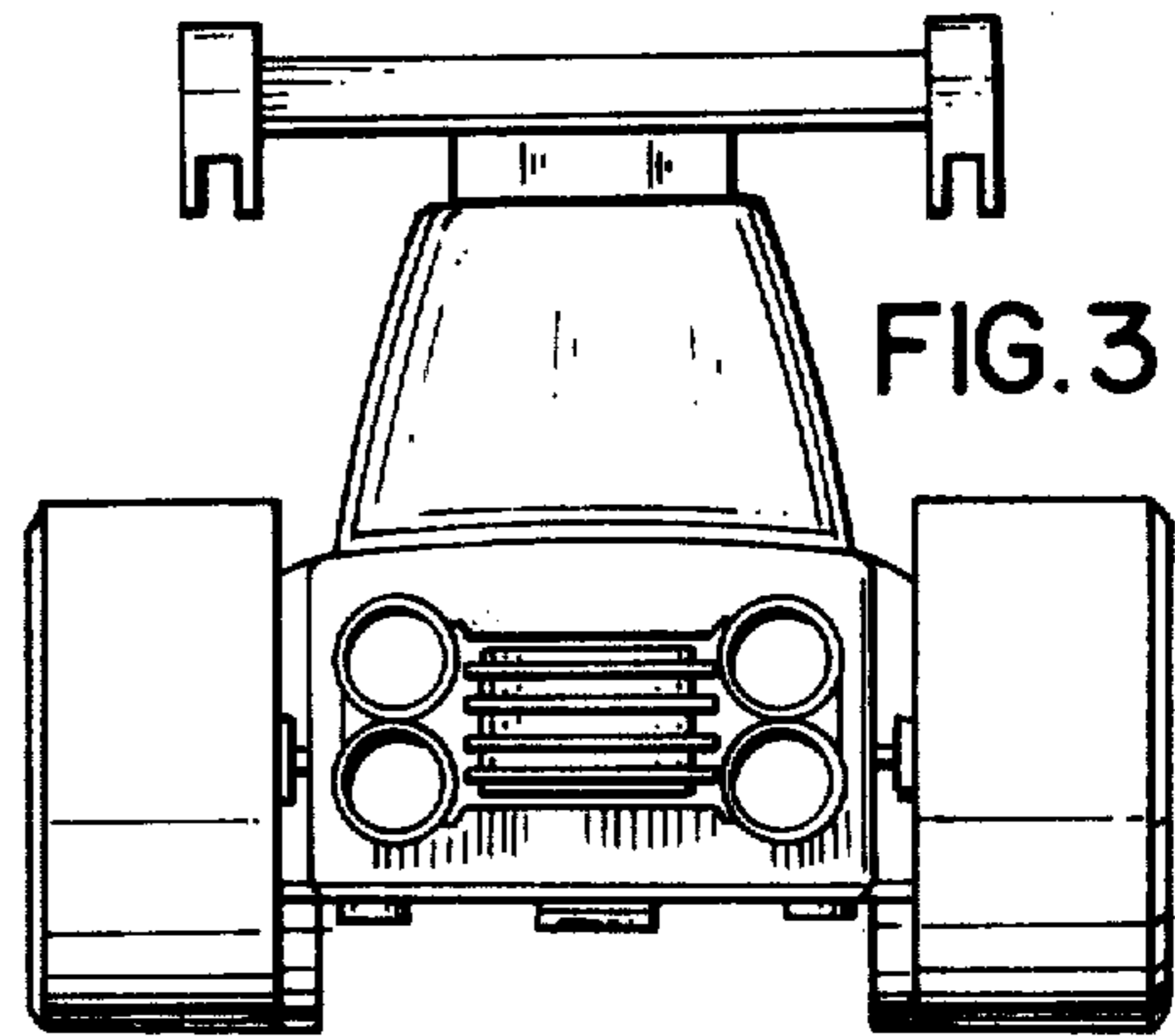

FIG. 3

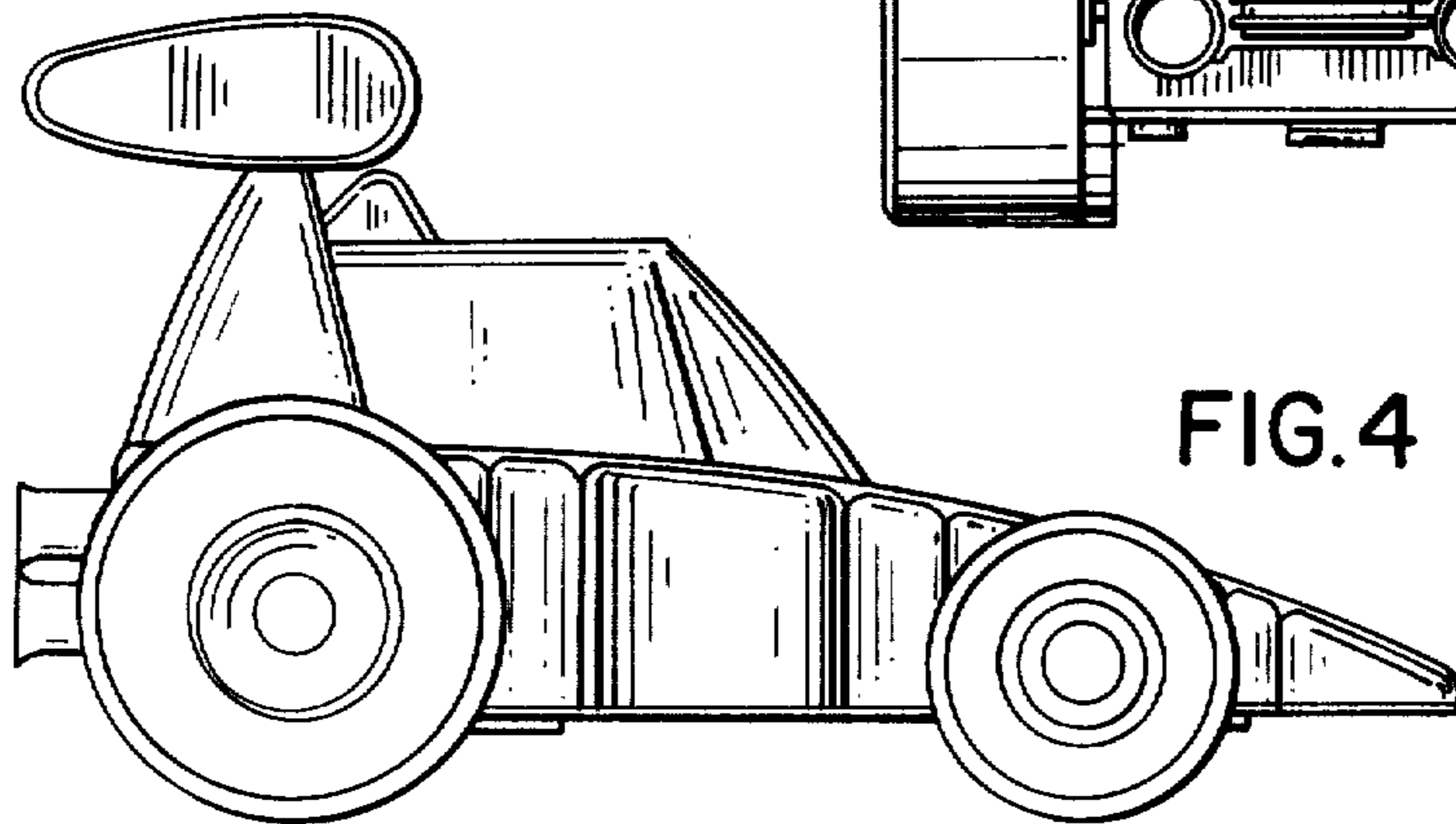

FIG. 4

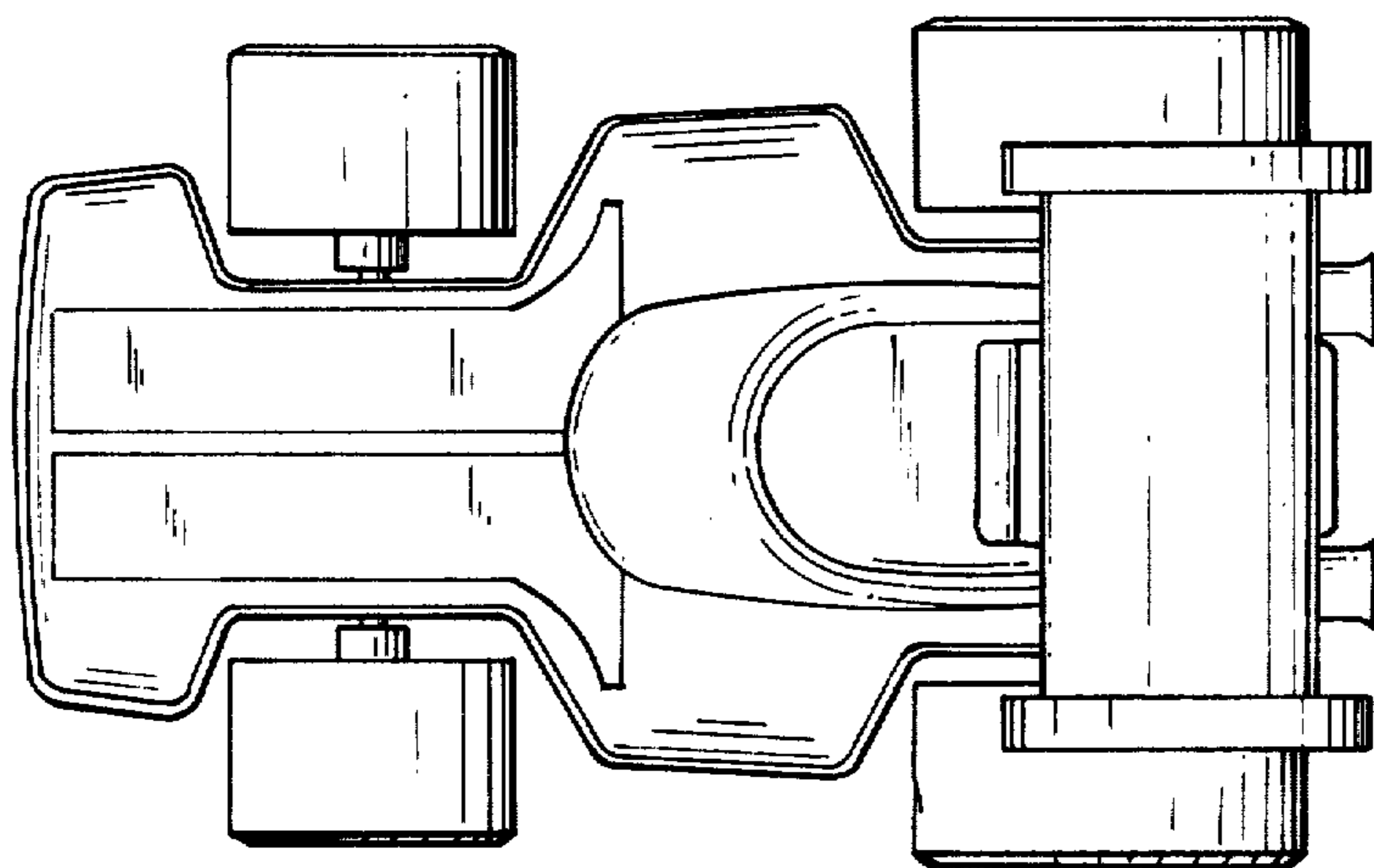
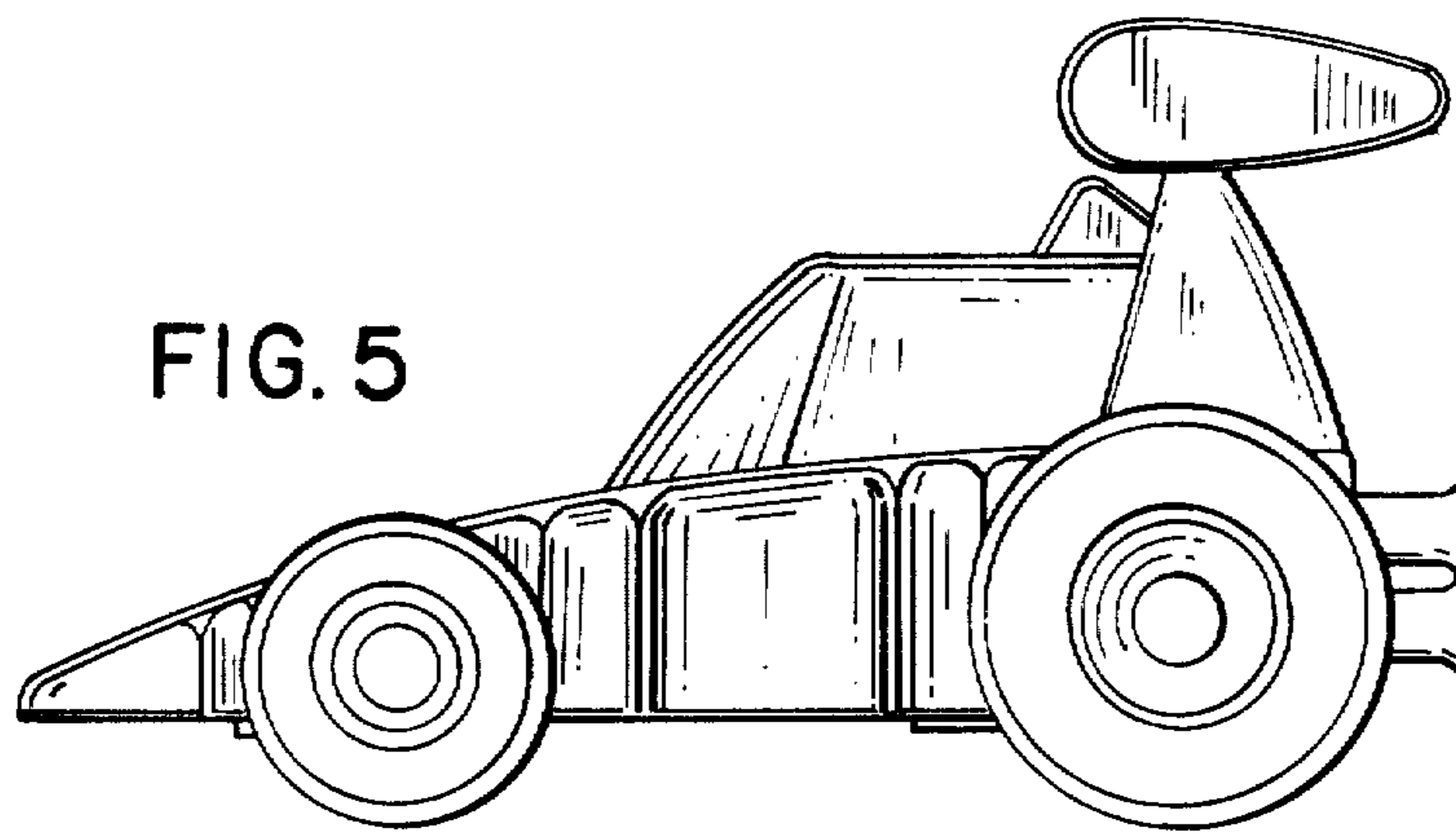

FIG. 6

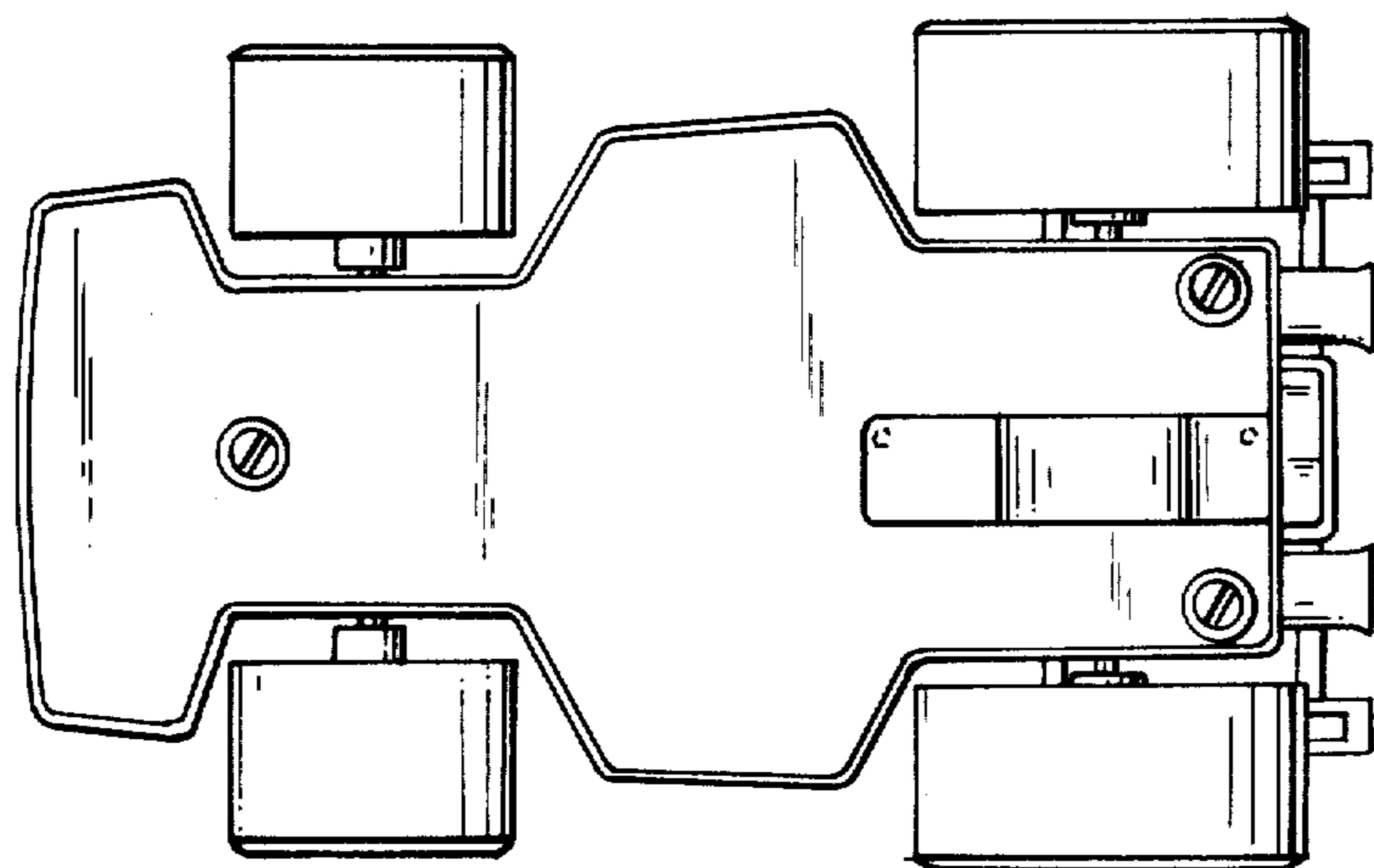

FIG. 7