

[54] **TRUCK**

[75] **Inventor:** Guido Magnini, Brescia, Italy

[73] **Assignee:** Fiat Veicoli Industriali S.p.A., Turin, Italy

[**] **Term:** 14 Years

[21] **Appl. No.:** 940,239

[22] **Filed:** Sep. 7, 1978

[30] **Foreign Application Priority Data**

Mar. 14, 1978 [IT] Italy 53021/78[U]

[51] **Int. Cl.** D12-08

[52] **U.S. Cl.** D12/98

[58] **Field of Search** D12/98, 96, 15;
296/184, 183

[56]

References Cited
PUBLICATIONS

Commercial Motor, 101/14/77, P78, Truck in box No. 3, bottom right side of page.

Commercial Motor, 7/1/77, P82, Truck, center left side of page.

Commercial Motor, 10/28/77, P49, truck, bottom of page.

Primary Examiner—James M. Gandy
Attorney, Agent, or Firm—Sughrue, Mion, Zinn, Macpeak & Seas

[57]

CLAIM

The ornamental design for a truck, as shown and described.

DESCRIPTION

FIG. 1 is a side elevational view of a truck showing my new design, it being understood that the opposite side is substantially a mirror image thereof.

FIG. 2 is a plan view

FIG. 3 is a front elevational view

FIG. 4 is a perspective view

FIG. 5 is a rear elevational view.

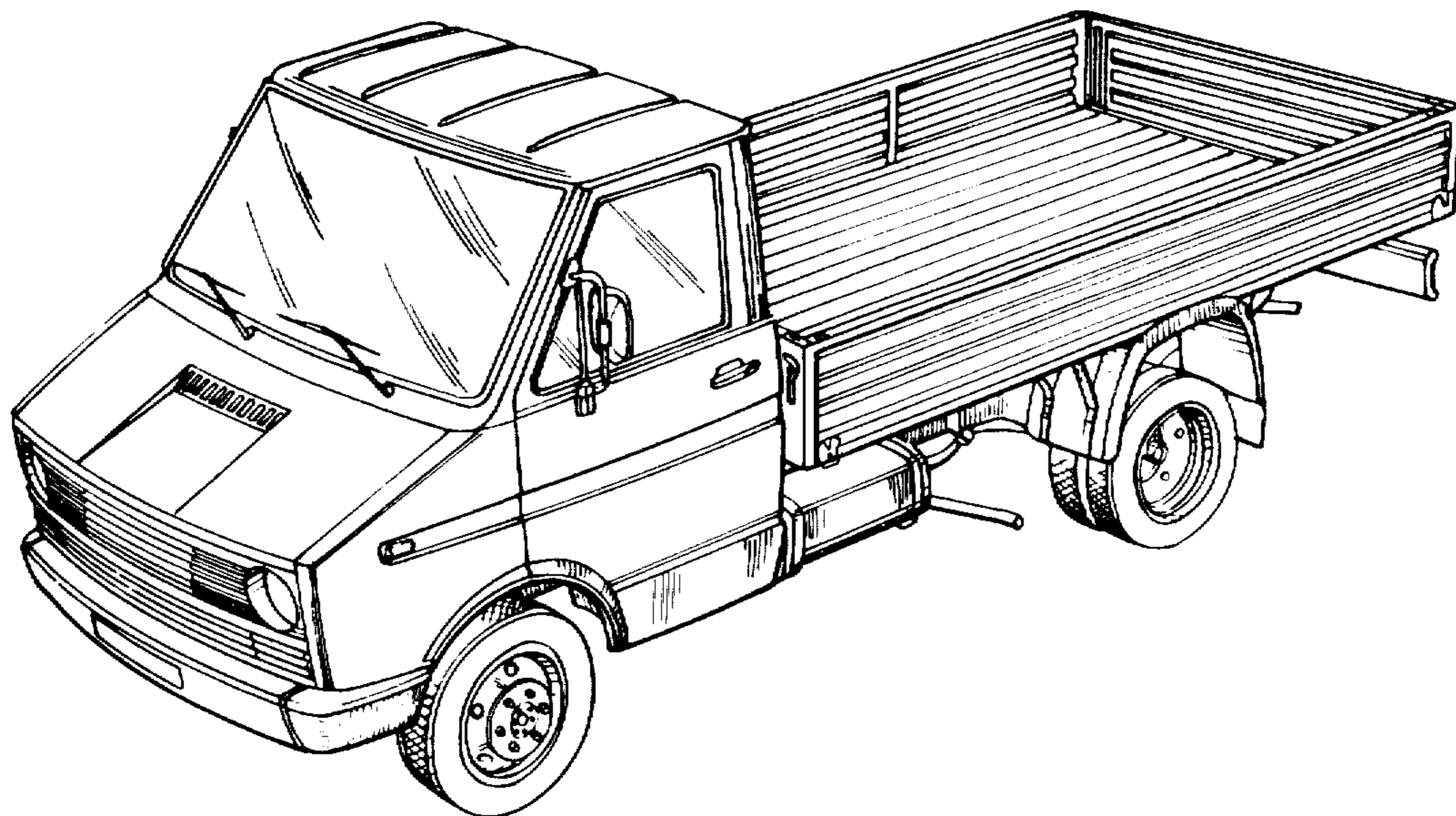

FIG. 1

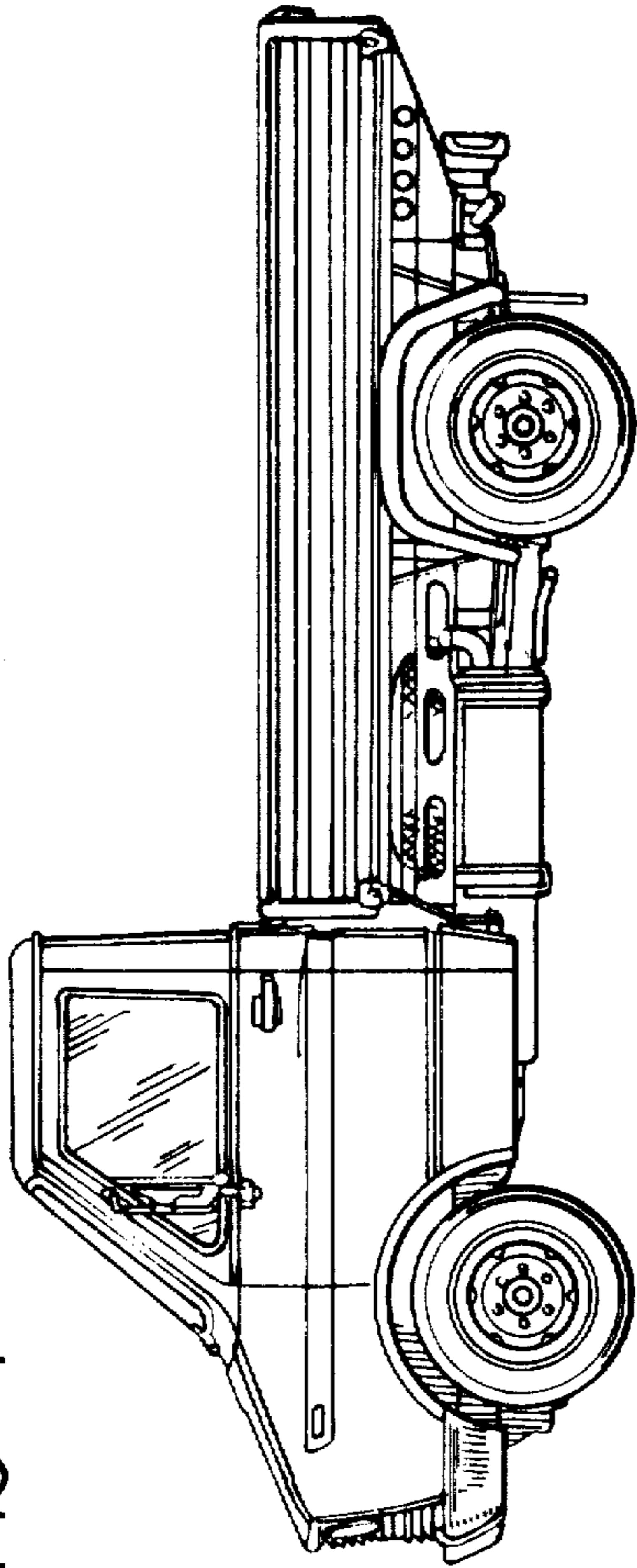

FIG. 3

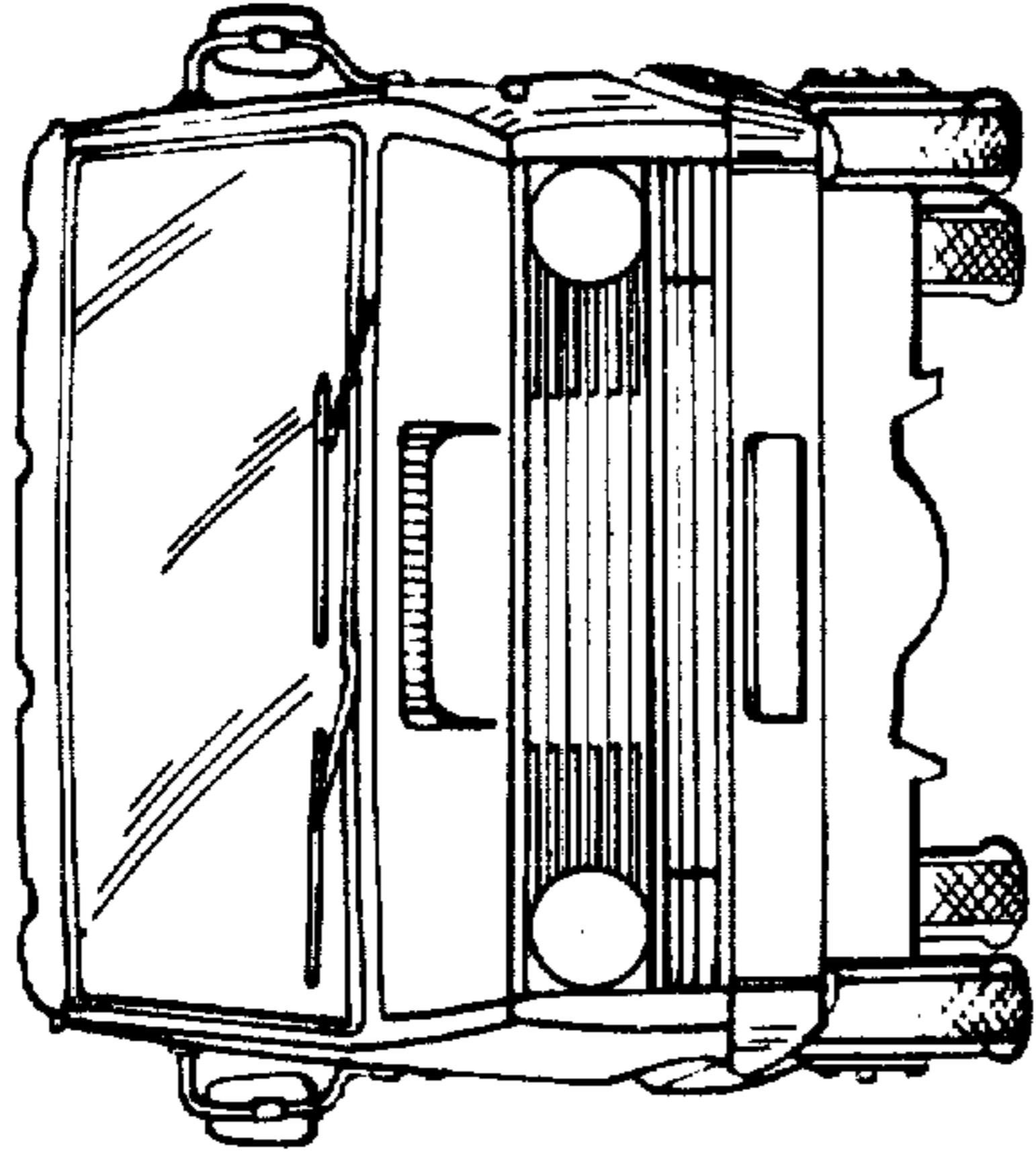

FIG. 2

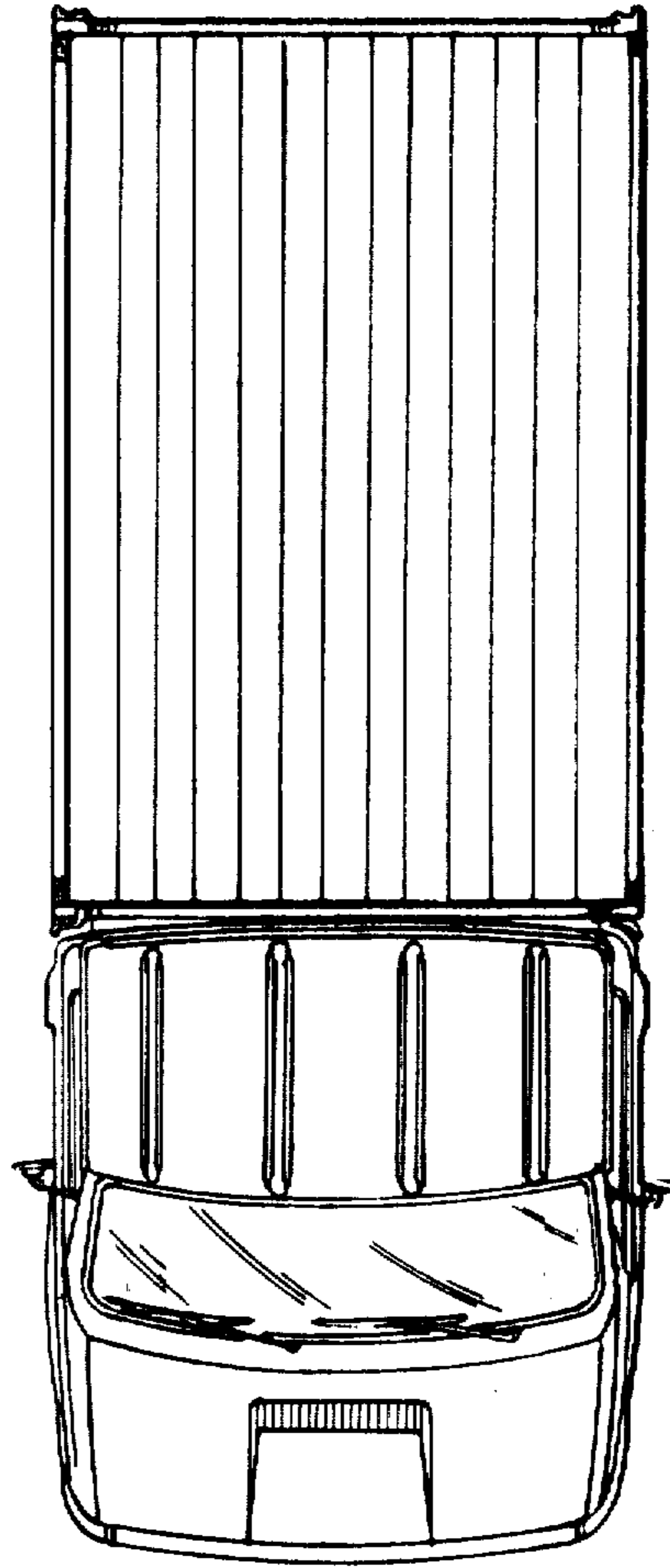

FIG. 5

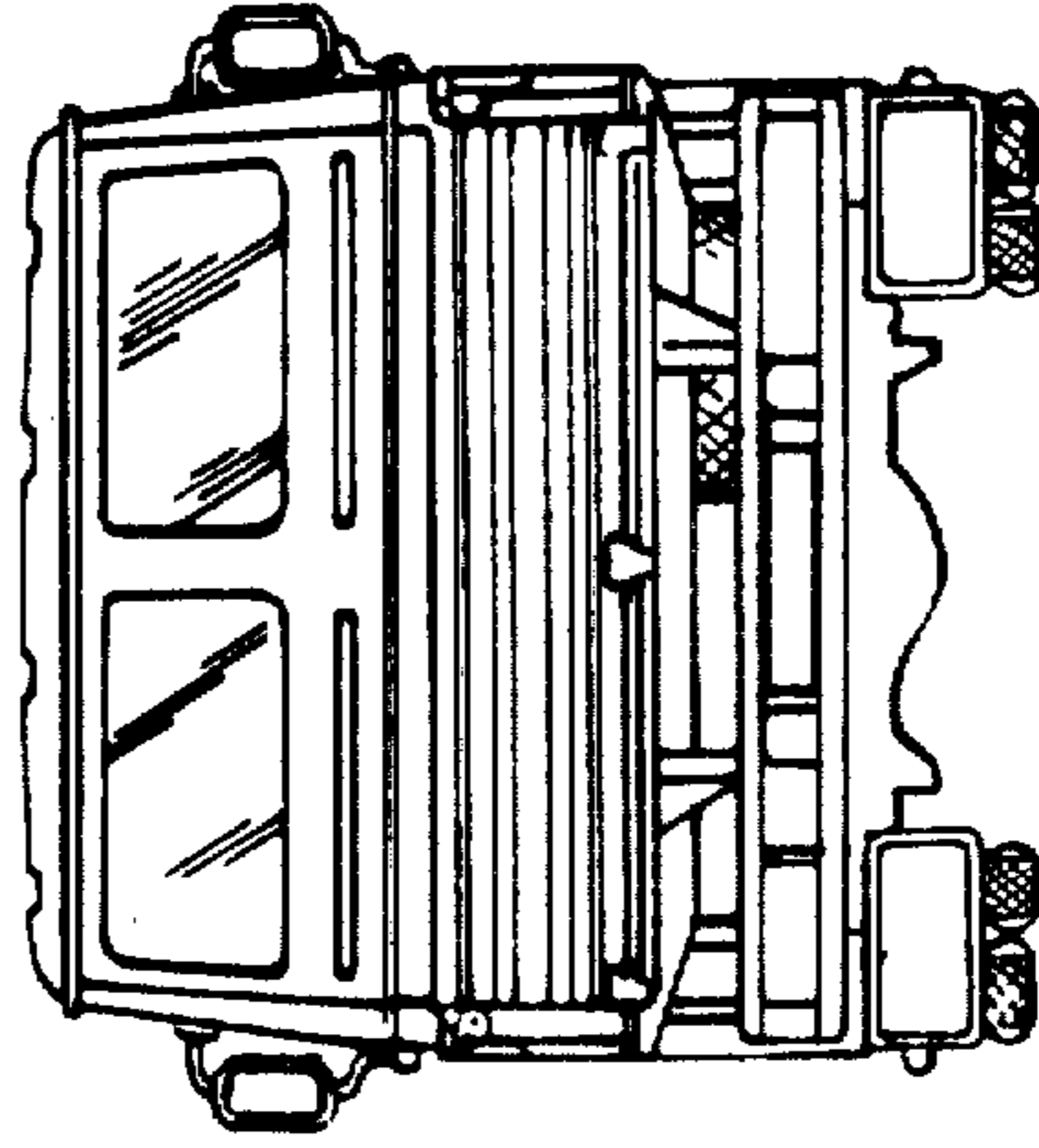

FIG. 4

