

[54] MOBILE WOOD CARRIER

[75] Inventor: Donald C. Jean, Palmer Township, Northampton County, Pa.

[73] Assignees: Earl C. Clymer, Jr., Phillipsburg; Thomas J. Middleton, Branchburg, both of N.J. ; a part interest to each

[\*\*] Term: 14 Years

[21] Appl. No.: 186,721

[22] Filed: Sep. 11, 1980

[51] Int. Cl. .... D12-02

[52] U.S. Cl. .... D34/24

[58] Field of Search ..... D34/24, 26; D7/212; 280/47.13, 47.17, 47.18, 47.24, 47.26, 47.28, 47.29; 211/60 R

[56] References Cited

U.S. PATENT DOCUMENTS

- D. 146,848 6/1947 Brickson ..... D34/24
- 2,881,007 4/1959 Karwatt et al. .... 280/47.13 R
- 4,294,364 10/1981 Bilbrey ..... 211/60 R

OTHER PUBLICATIONS

New Hampton General Store Spring 1980 Catalog, p. 41, Log Tram, Item F, center of page.

Primary Examiner—James M. Gandy

Attorney, Agent, or Firm—Joseph W. Molasky & Associates

[57] CLAIM

The ornamental design for a mobile wood carrier, substantially as shown and described.

DESCRIPTION

FIG. 1 is a perspective view of a mobile wood carrier showing my new design;

FIG. 2 is a side elevational view thereof, on a reduced scale;

FIG. 3 is a top plan view thereof on a reduced scale;

FIG. 4 is a bottom plan view thereof on a reduced scale;

FIG. 5 is an elevational view from the right end of FIG. 1 on a reduced scale;

FIG. 6 is an elevational view from the left end of FIG. 1 on a reduced scale;

FIG. 7 is a perspective view thereof with the handle removed and in an alternate condition of use;

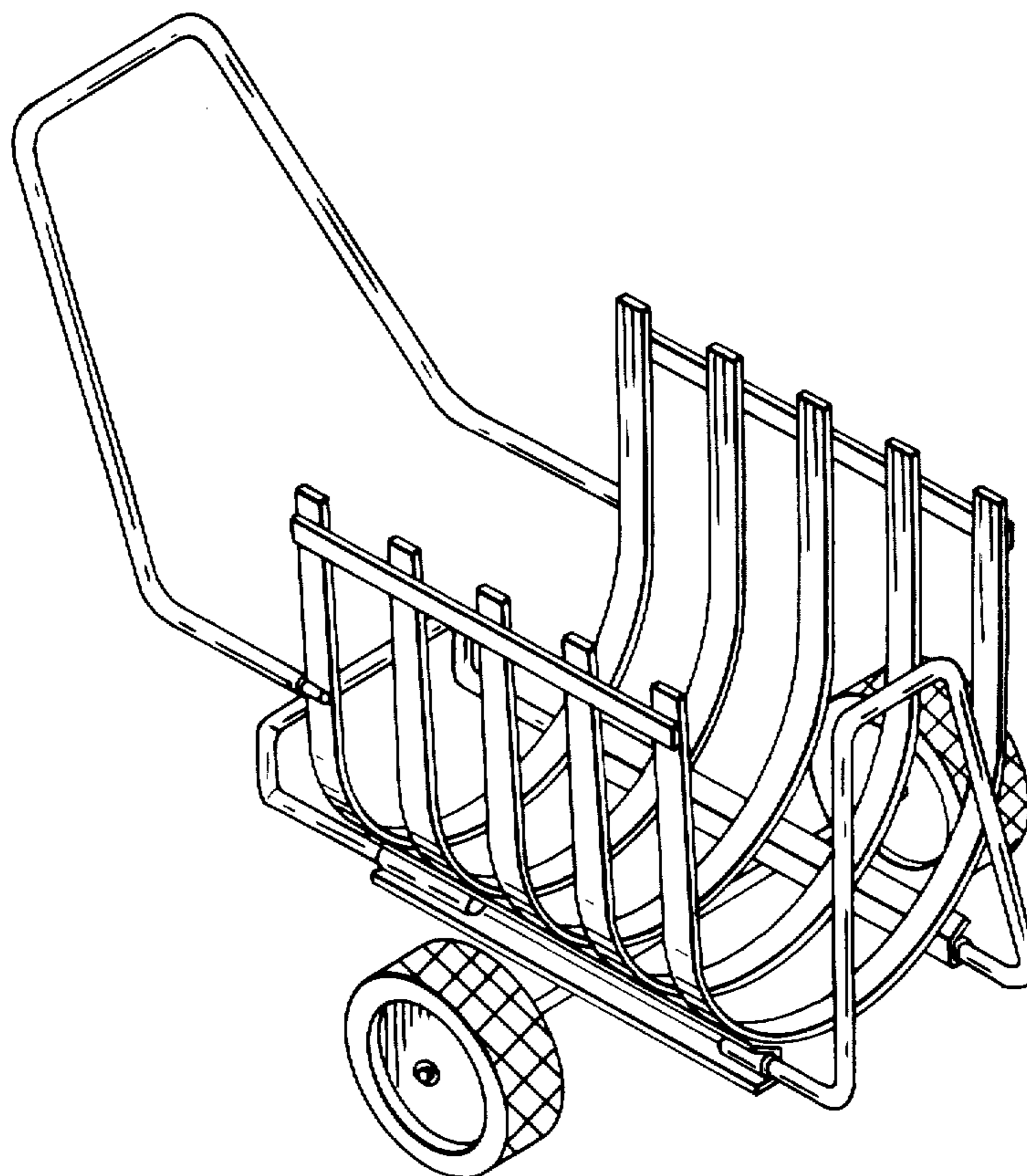
FIG. 8 is a side elevational view of FIG. 7, on a reduced scale;

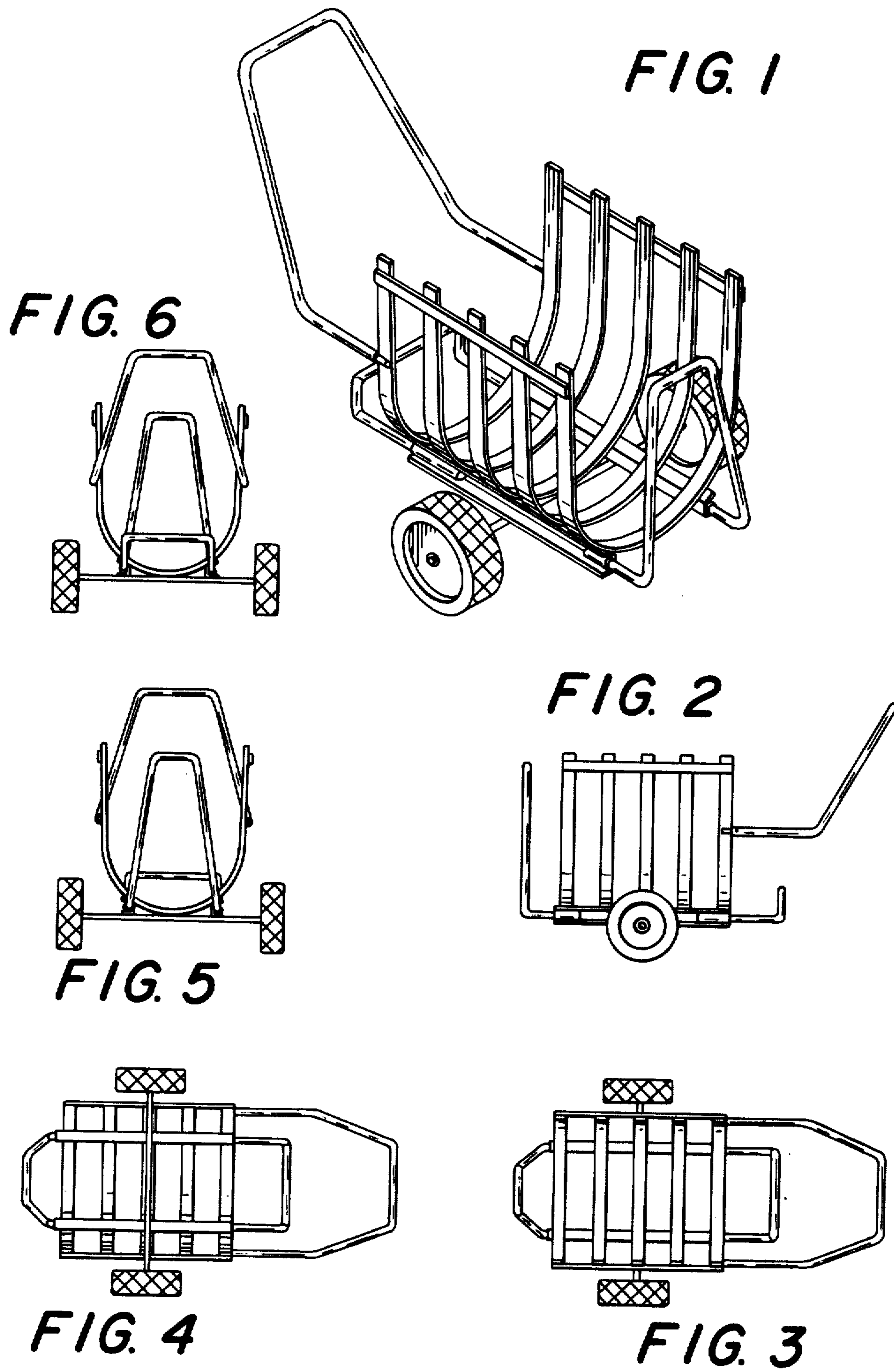
FIG. 9 is a top plan view of FIG. 7 on a reduced scale;

FIG. 10 is a bottom plan view of FIG. 7 on a reduced scale;

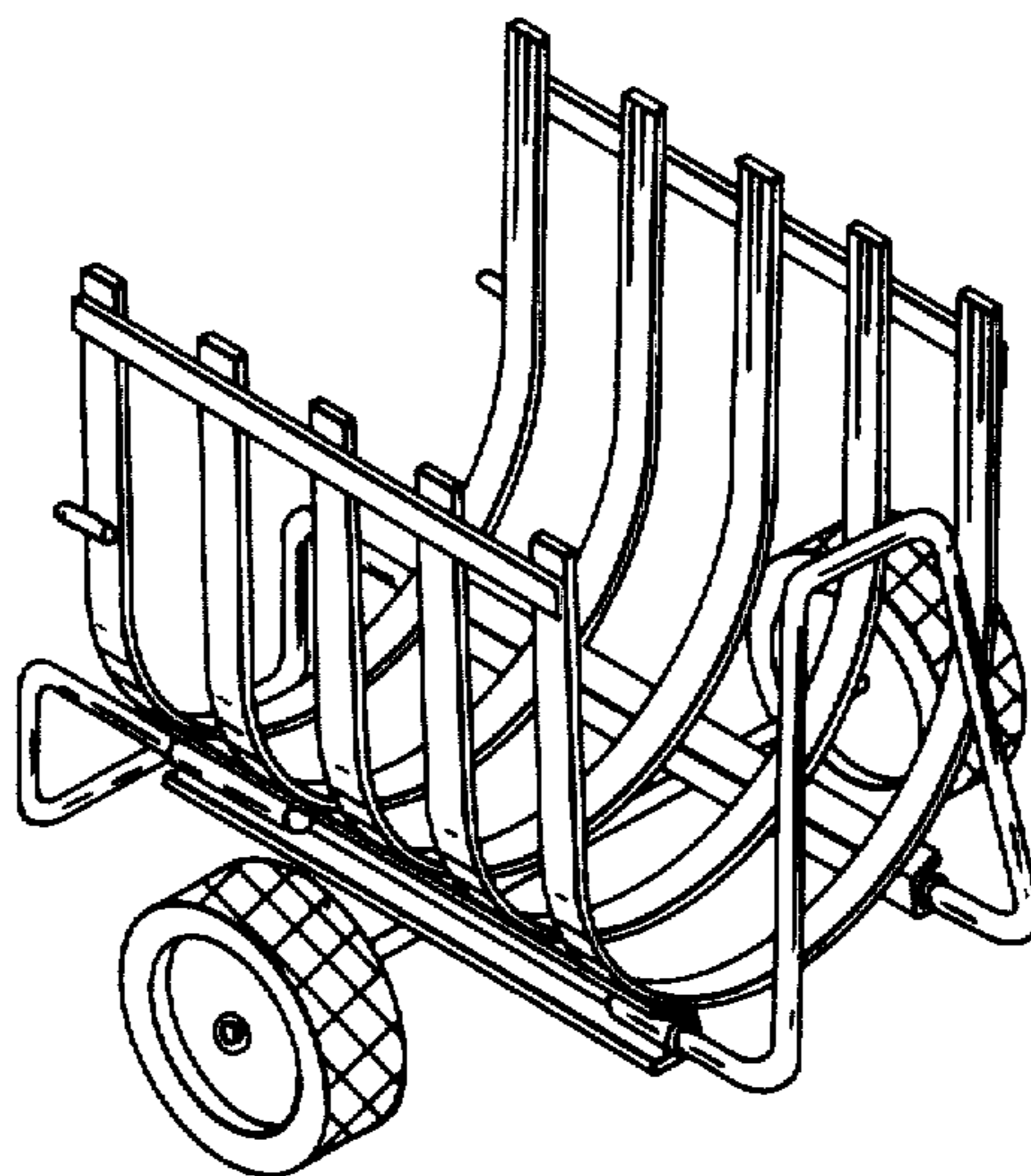
FIG. 11 is an elevational view from the right end of FIG. 7 on a reduced scale; and

FIG. 12 is an elevational view from the left end of FIG. 7 on a reduced scale.

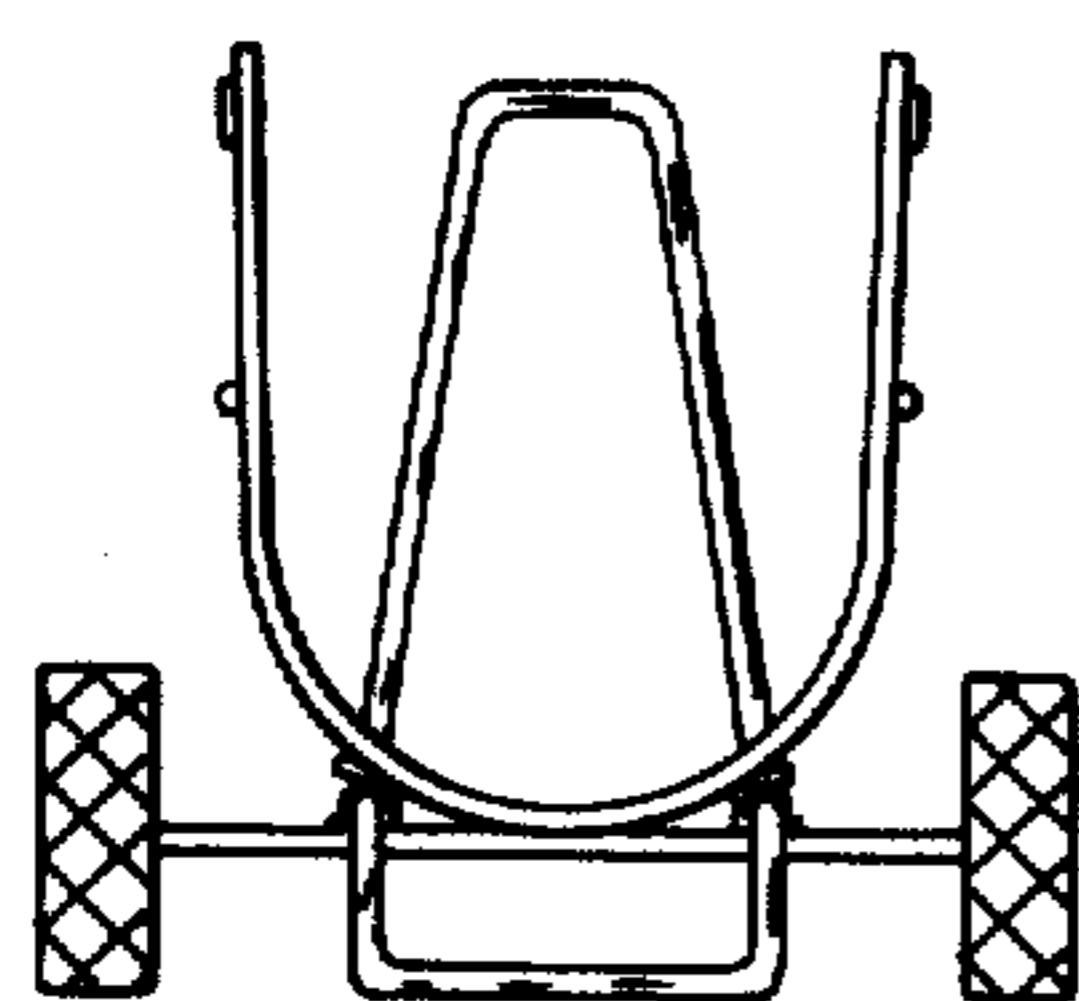




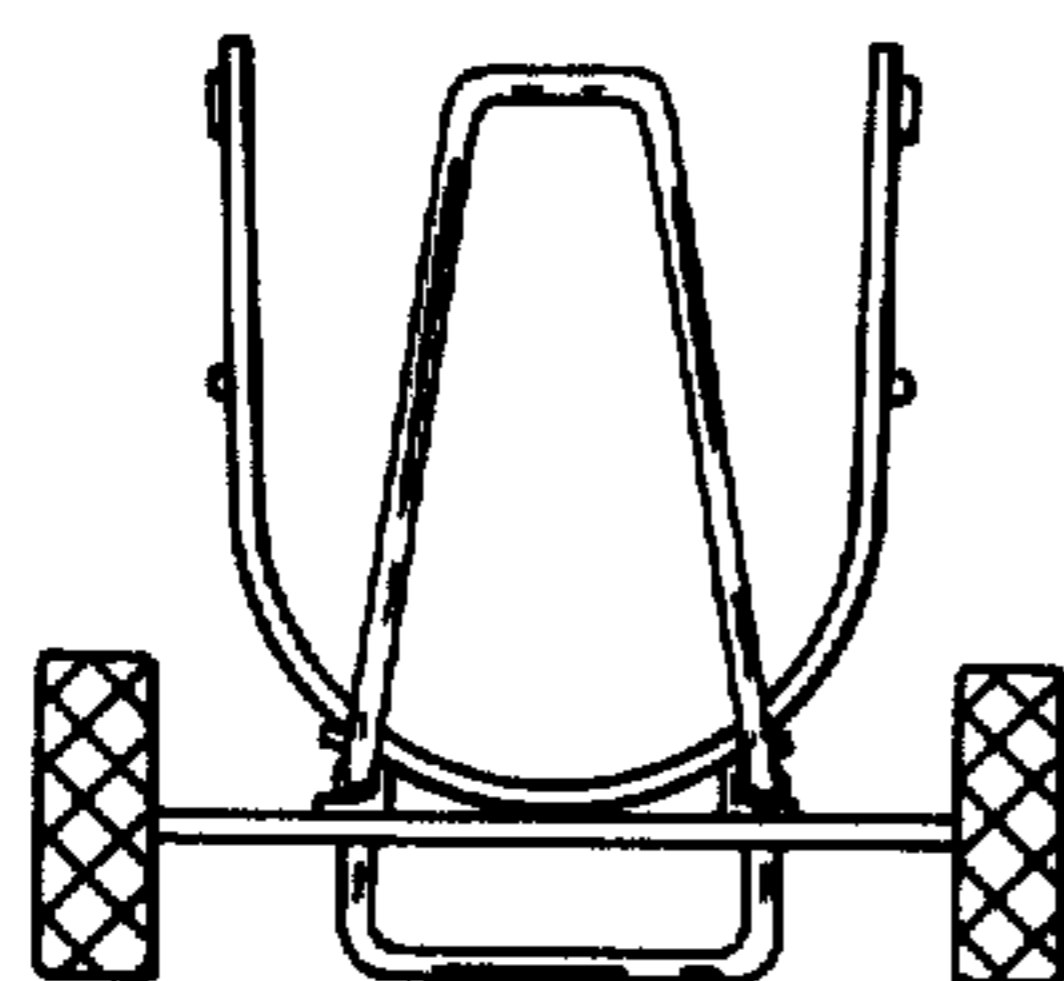
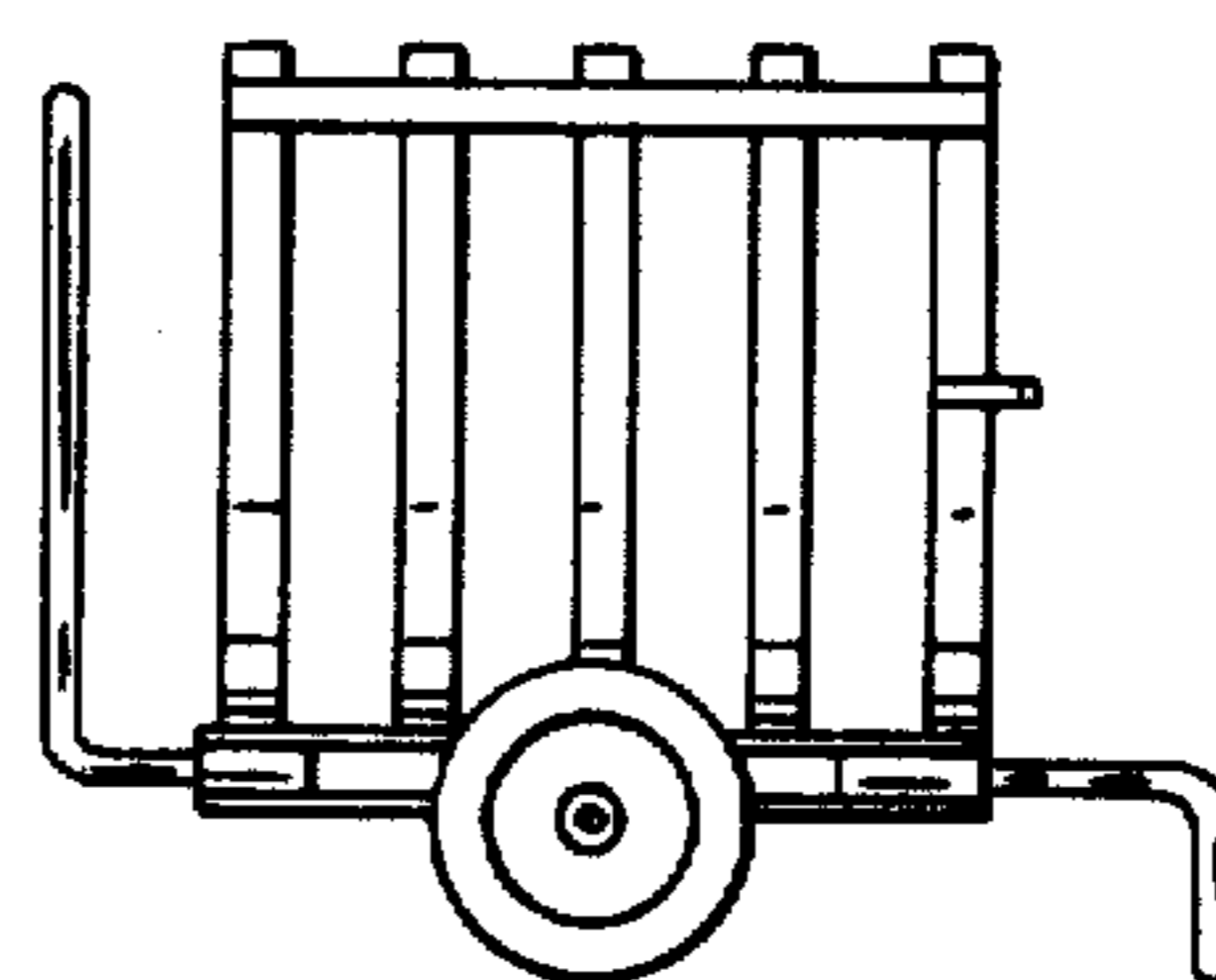
**FIG. 7**



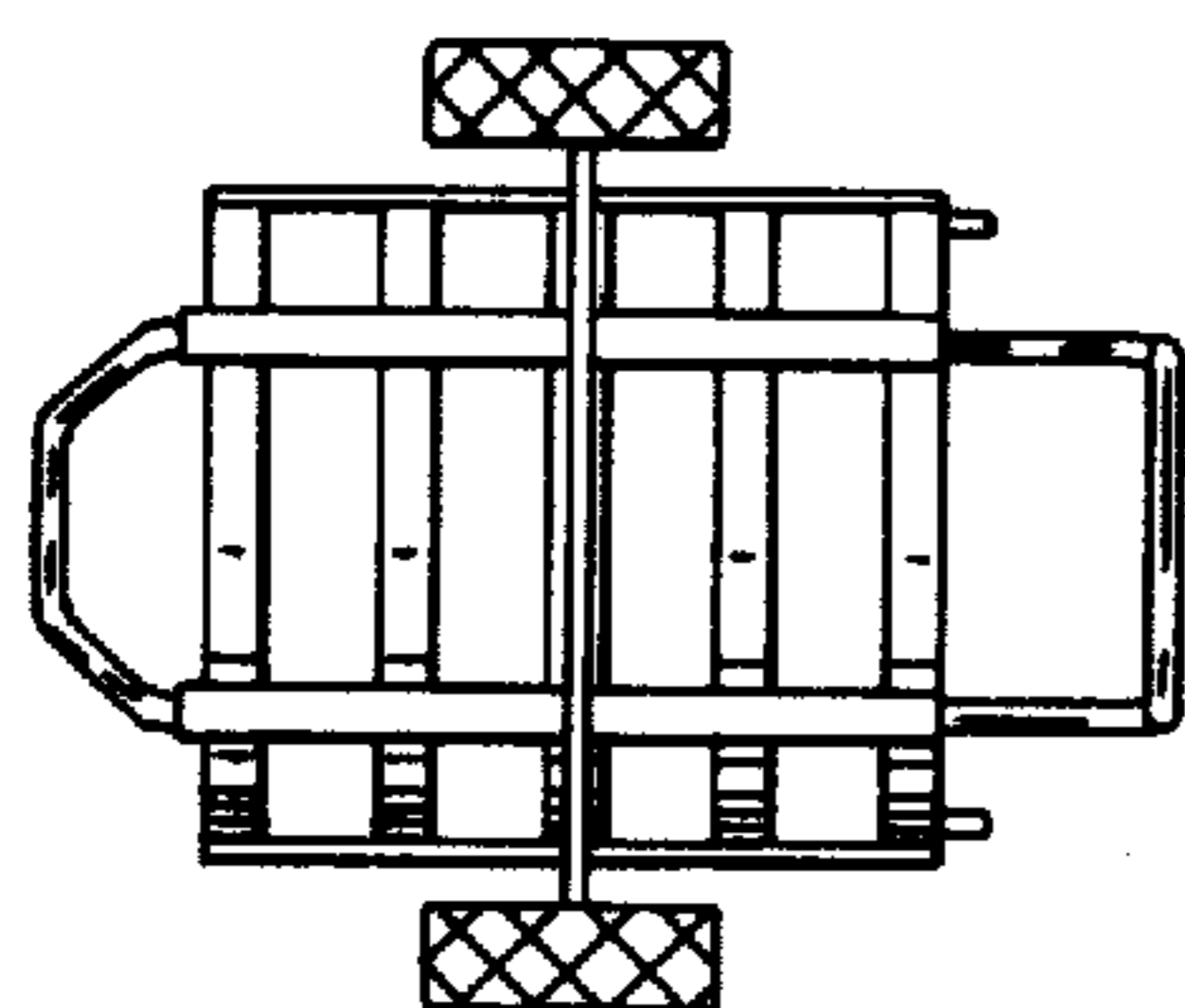
**FIG. 12**



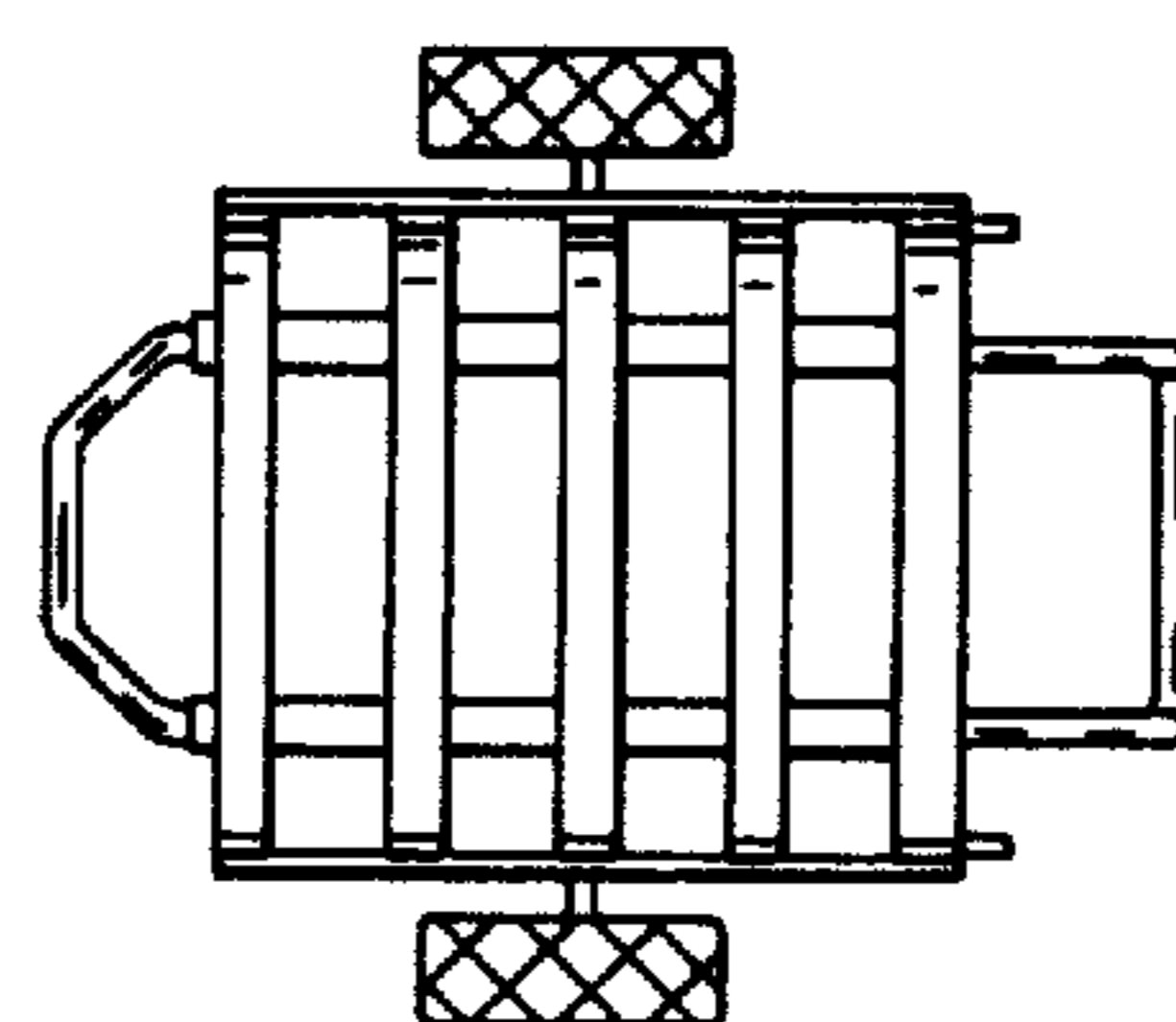
**FIG. 8**



**FIG. 11**



**FIG. 10**



**FIG. 9**