

[54] SPA TABLE

3,367,525 2/1968 Elder D7/71 X

[75] Inventors: Donald W. Doman, Janesville; Alfred W. Elsner, Plymouth, both of Wis.

[73] Assignee: Kohler Co., Kohler, Wis.

[**] Term: 14 Years

[21] Appl. No.: 172,458

[22] Filed: Jul. 25, 1980

[51] Int. Cl. D6-06

[52] U.S. Cl. D6/177; D6/146; D7/21; D7/37; D24/38

[58] Field of Search D24/38; D6/177, 146, D6/138, 199; D7/108, 109, 21, 37, 27

[56] References Cited

U.S. PATENT DOCUMENTS

D. 203,603	2/1966	Poletika	D6/177
D. 219,108	11/1970	Lange	D6/146
D. 232,793	9/1974	Marwood	D6/146
D. 239,673	4/1976	Zieler	D6/146

OTHER PUBLICATIONS

"Tub & Spa Gallery", p. 49, Gill Gillespie designed Spa.

Islander Spas flyer, 1979, "The Premier Sea Shell Collection".

Sunfloat Advertisement, 1979, "Now The Most Popular Game In The Country Can Be Played In The Water".

Primary Examiner—Bernard Ansher

Attorney, Agent, or Firm—Quarles & Brady

[57] CLAIM

The ornamental design for a spa table, as shown.

DESCRIPTION

FIG. 1 is a perspective view of a spa table showing our new design;

FIG. 2 is a side elevational view thereof;

FIG. 3 is a right end elevational view thereof;

FIG. 4 is a top plan view thereof; and

FIG. 5 is a bottom plan view thereof.

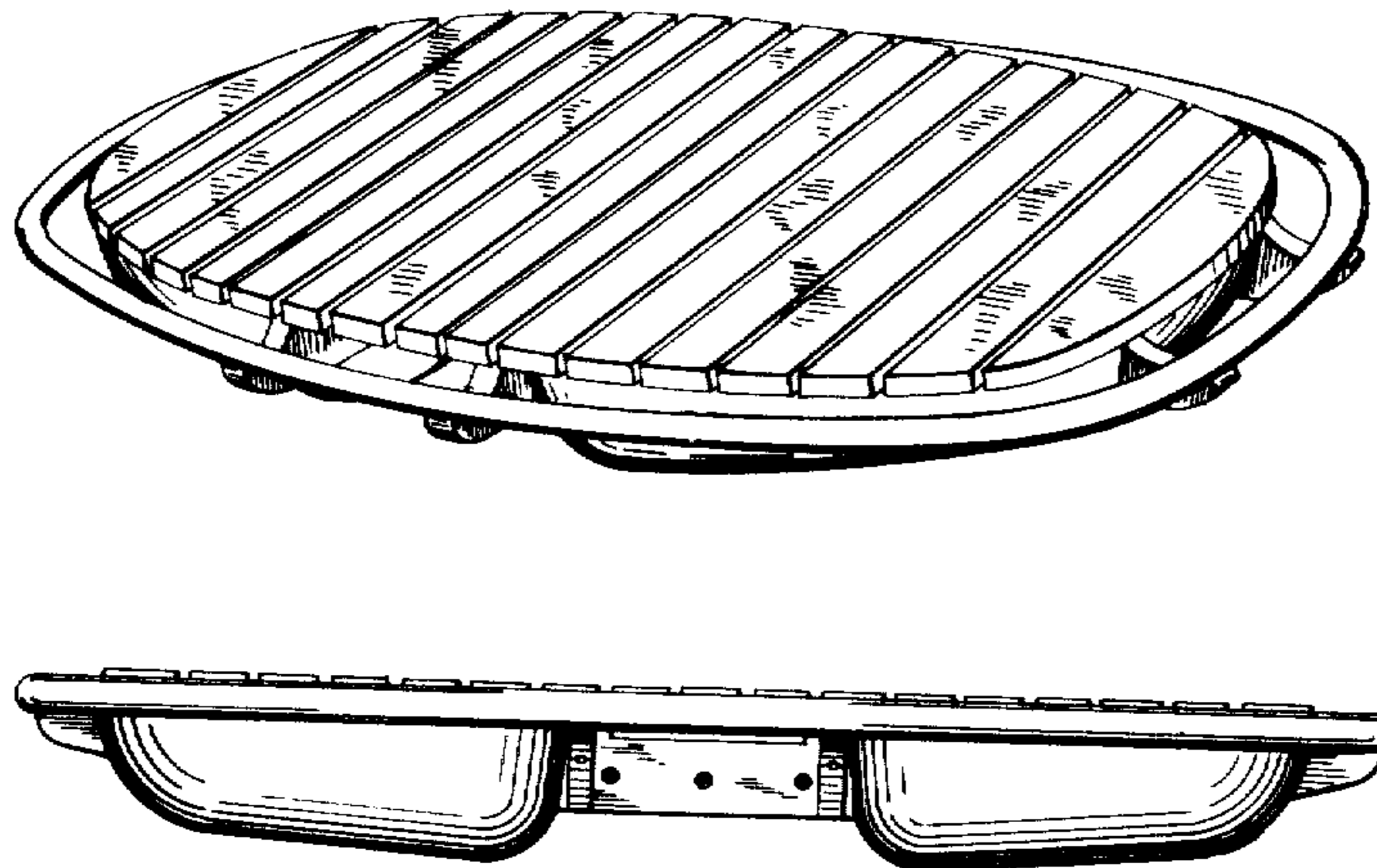

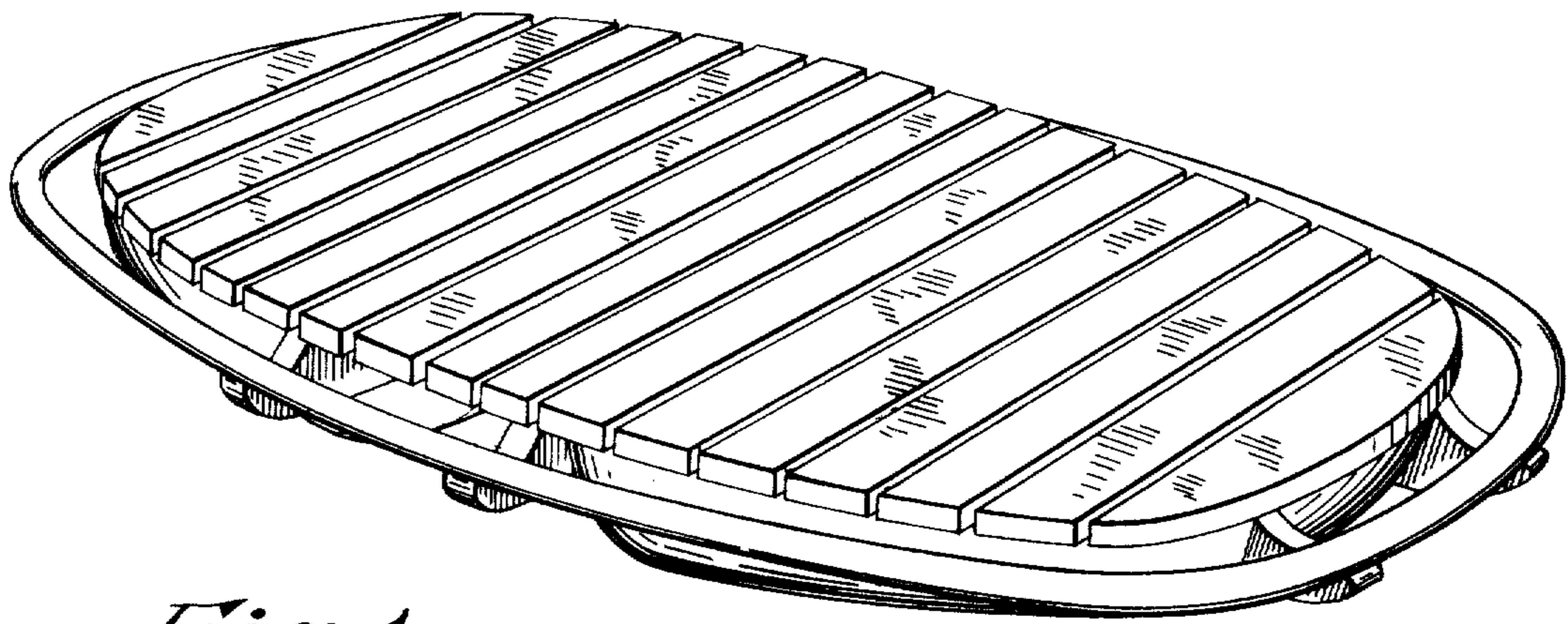

Fig. 1

Fig. 2

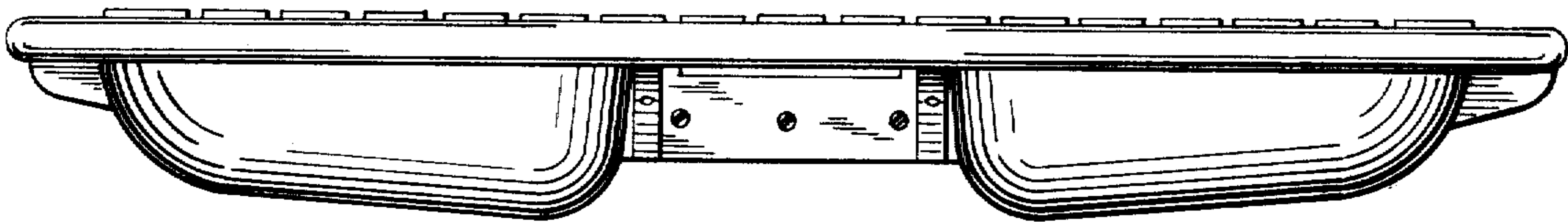
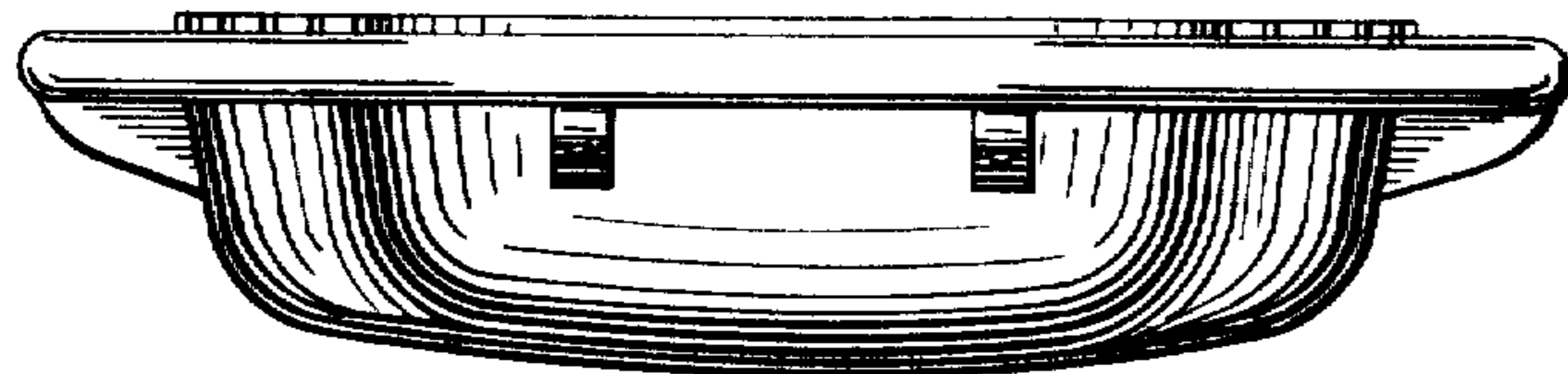

Fig. 3



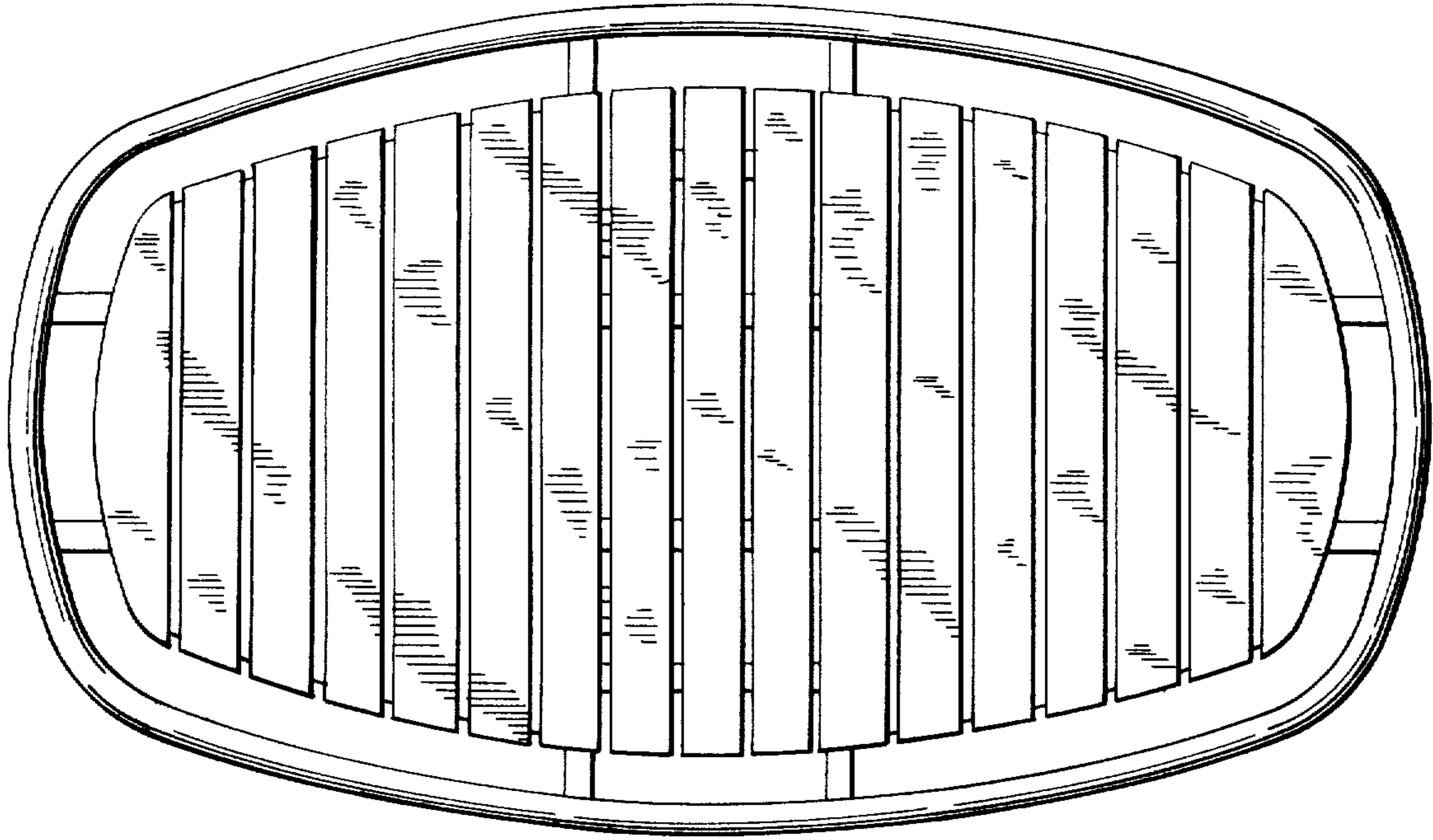

Fig. 4

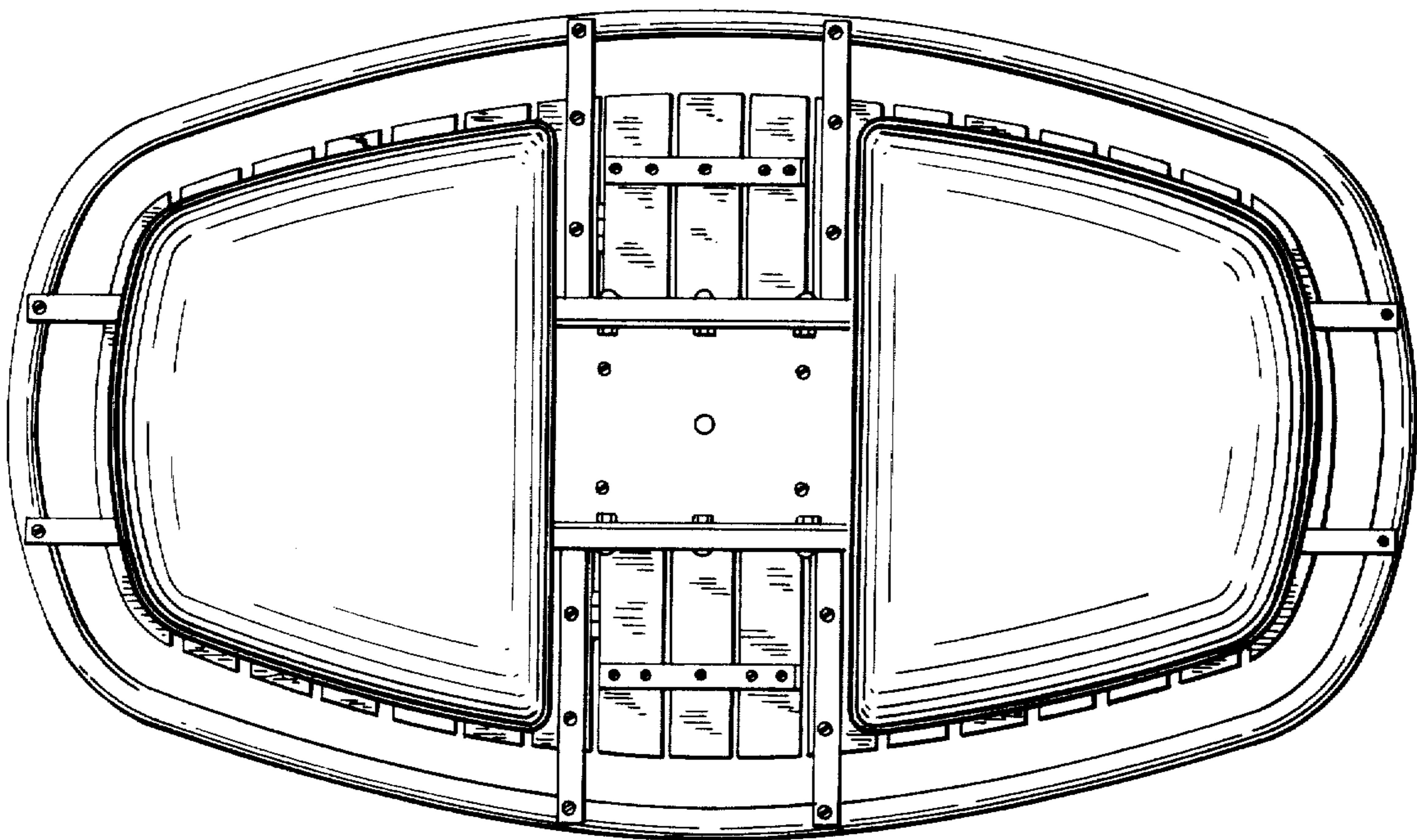

Fig. 5