

[54] AUTOMOBILE AUXILIARY LIGHT

[75] Inventor: Yoshikazu Suzuki, Yokohama, Japan

[73] Assignee: Ushio Denki Kabushiki Kaisha, Tokyo, Japan

[**] Term: 14 Years

[21] Appl. No.: 161,301

[22] Filed: Jun. 20, 1980

[51] Int. Cl. D26-06

[52] U.S. Cl. D26/28

[58] Field of Search D26/24, 28, 29, 30, D26/31, 34, 35, 36, 139; 362/61, 235, 250, 307, 310, 311, 341, 362, 363, 359, 369, 418, 419, 427

[56] References Cited

U.S. PATENT DOCUMENTS

- D. 258,692 3/1981 Ozeki D26/28
- 1,445,399 2/1923 Kilfoyle 362/359 X
- 2,713,114 7/1955 Boyd 362/359

FOREIGN PATENT DOCUMENTS

1334855 10/1973 United Kingdom 362/359

Primary Examiner—Susan J. Lucas
Attorney, Agent, or Firm—McCormick, Paulding & Huber

[57] CLAIM

The ornamental design for automobile auxiliary light, substantially as shown and described.

DESCRIPTION

FIG. 1 is a plan view of an automobile auxiliary light showing my new design;
 FIG. 2 is a front elevational view thereof;
 FIG. 3 is a right side elevational view thereof;
 FIG. 4 is a bottom view thereof;
 FIG. 5 is a rear elevational view thereof;
 FIG. 6 is a right side elevational view thereof with the cover in a closed position;
 FIG. 7 is a cross sectional view along the line 7—7 of FIG. 3; and
 FIG. 8 is a perspective view thereof.

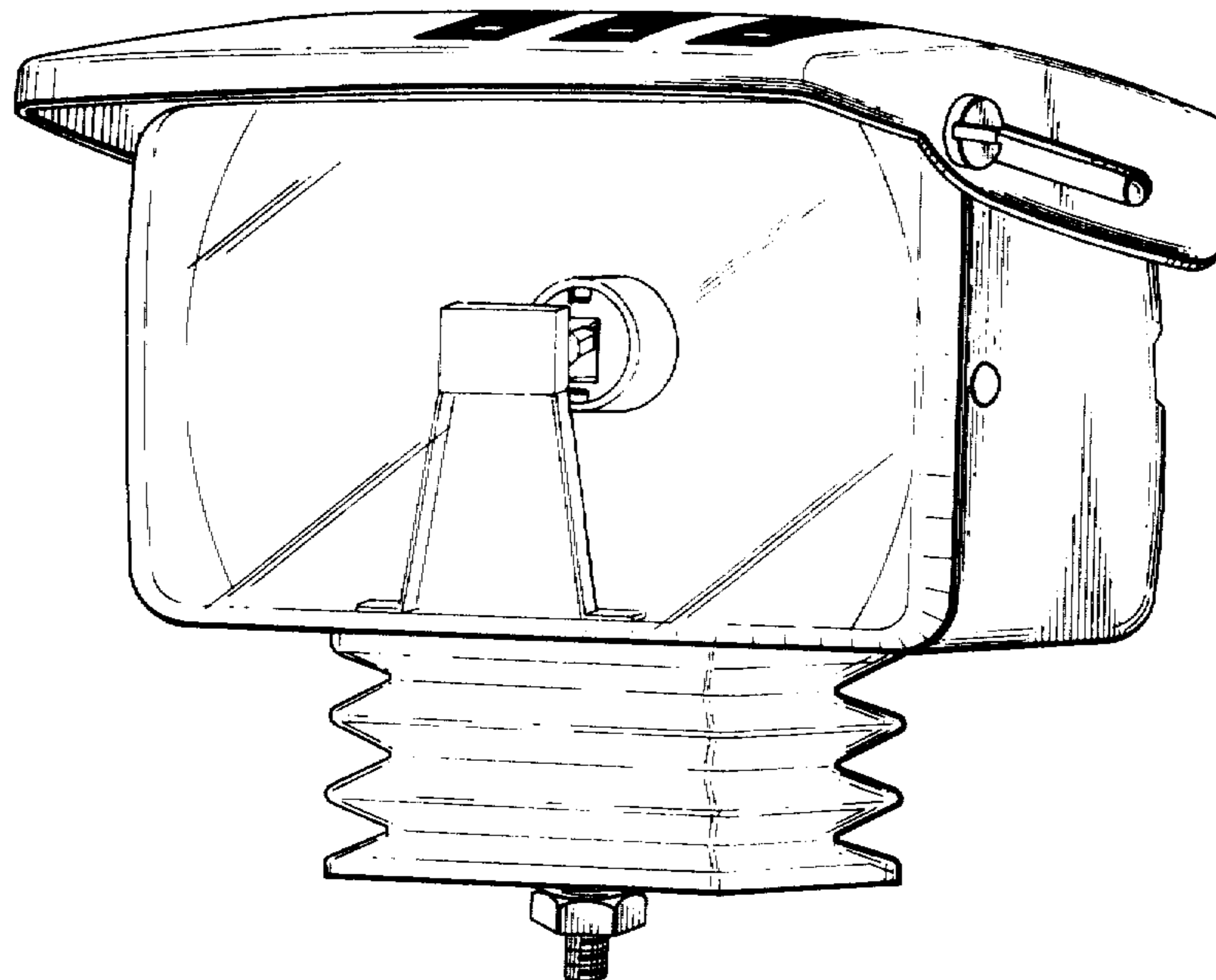

FIG. 1

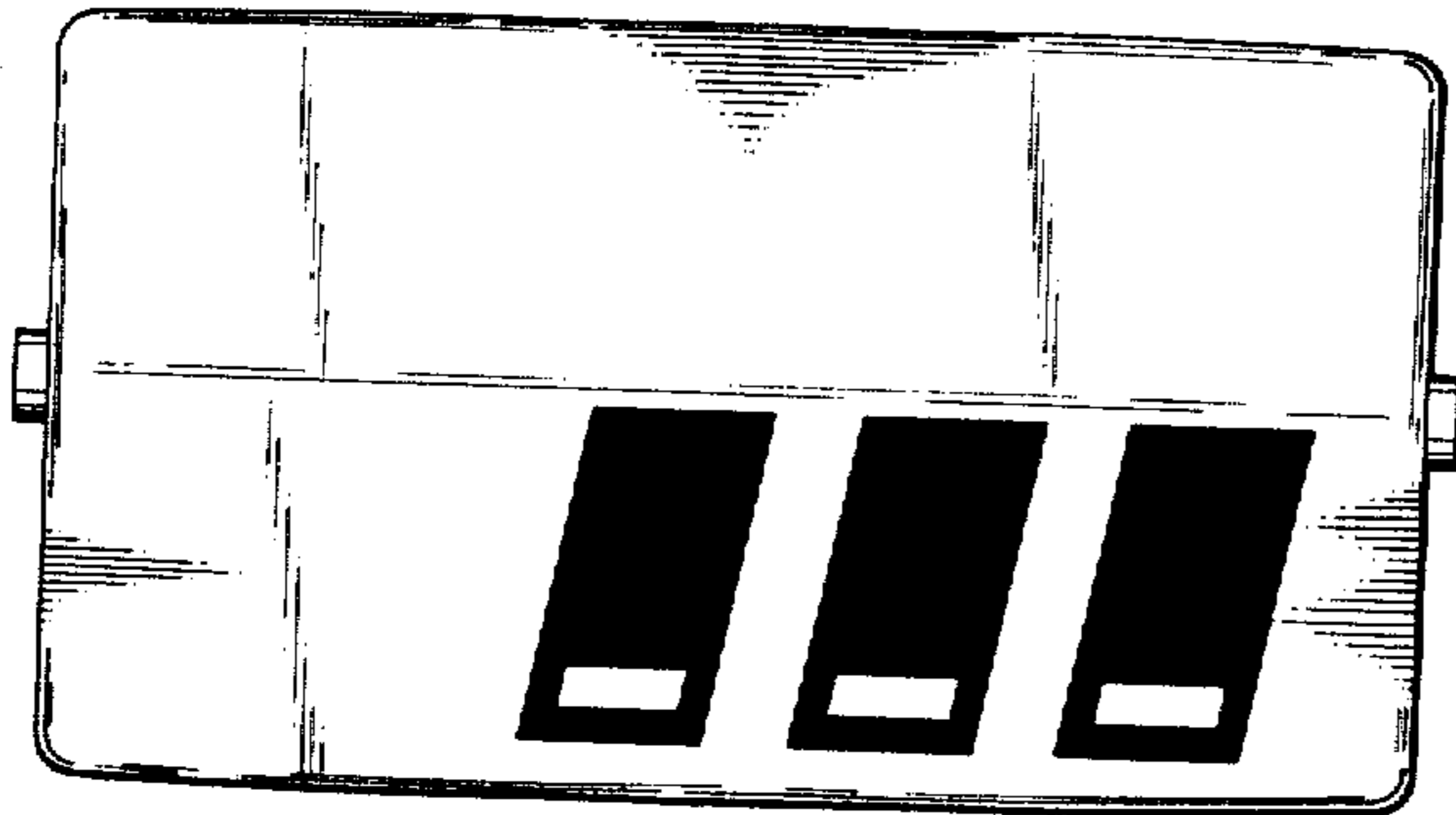

FIG. 2

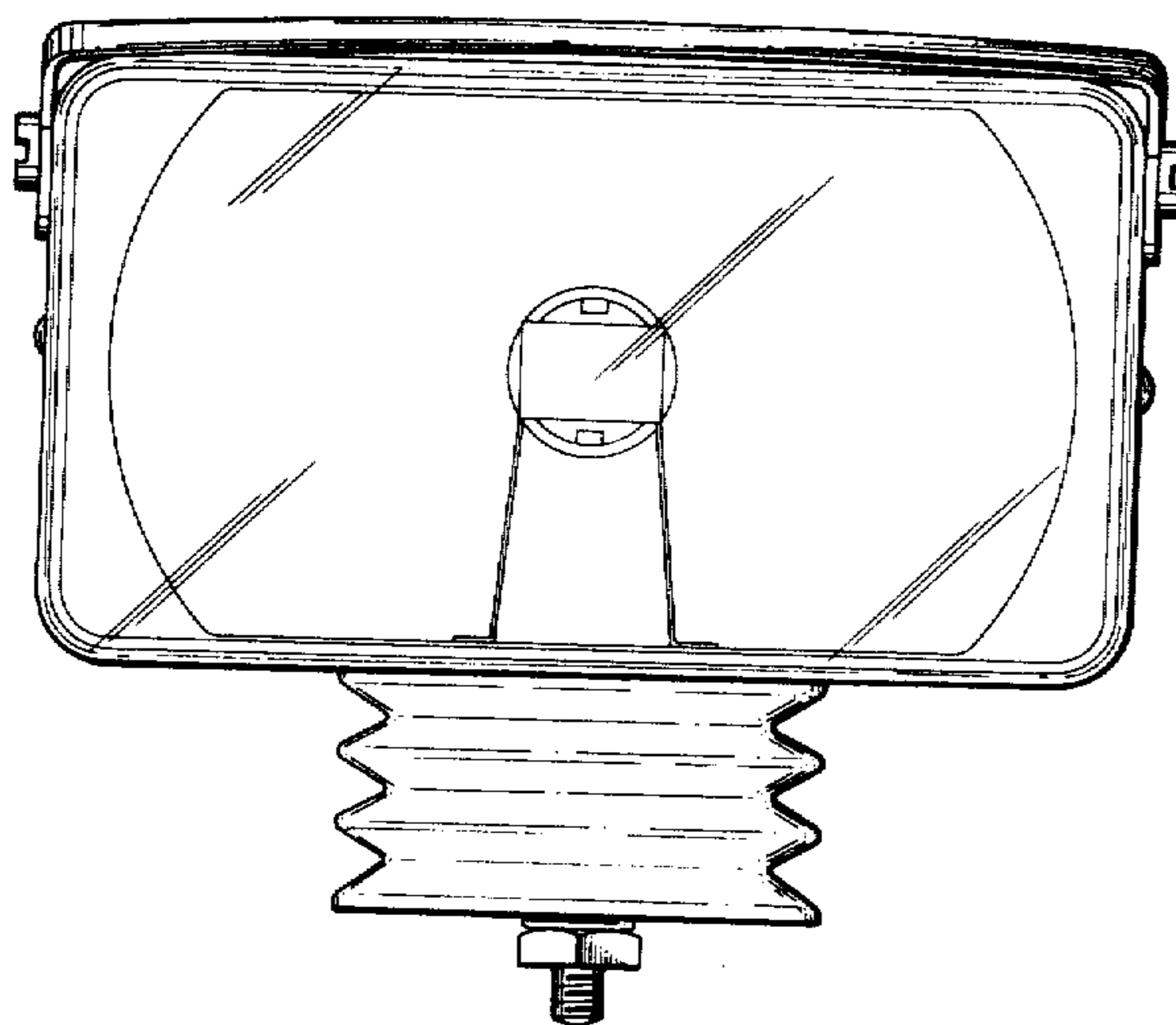

FIG. 3

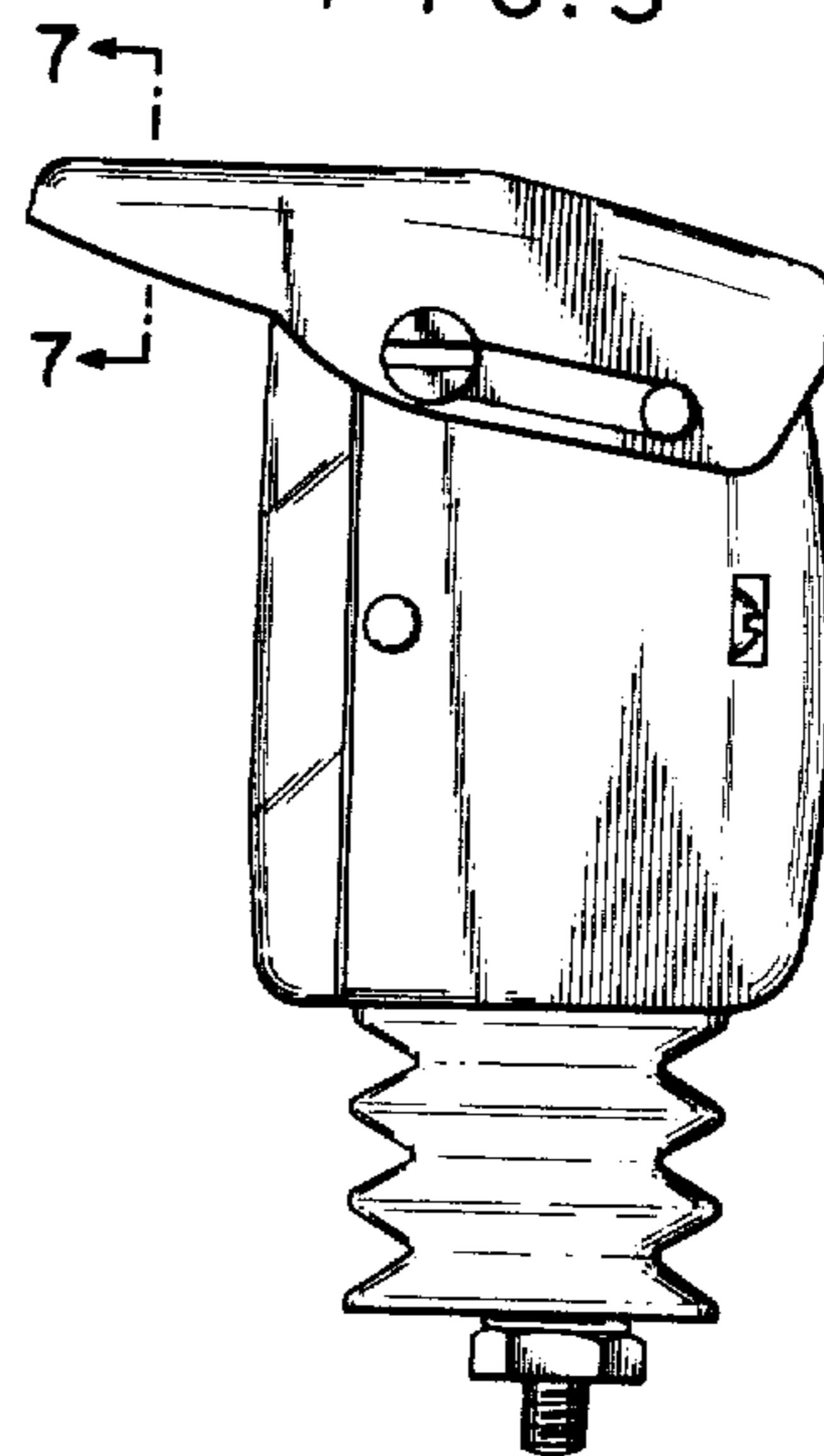

FIG. 4

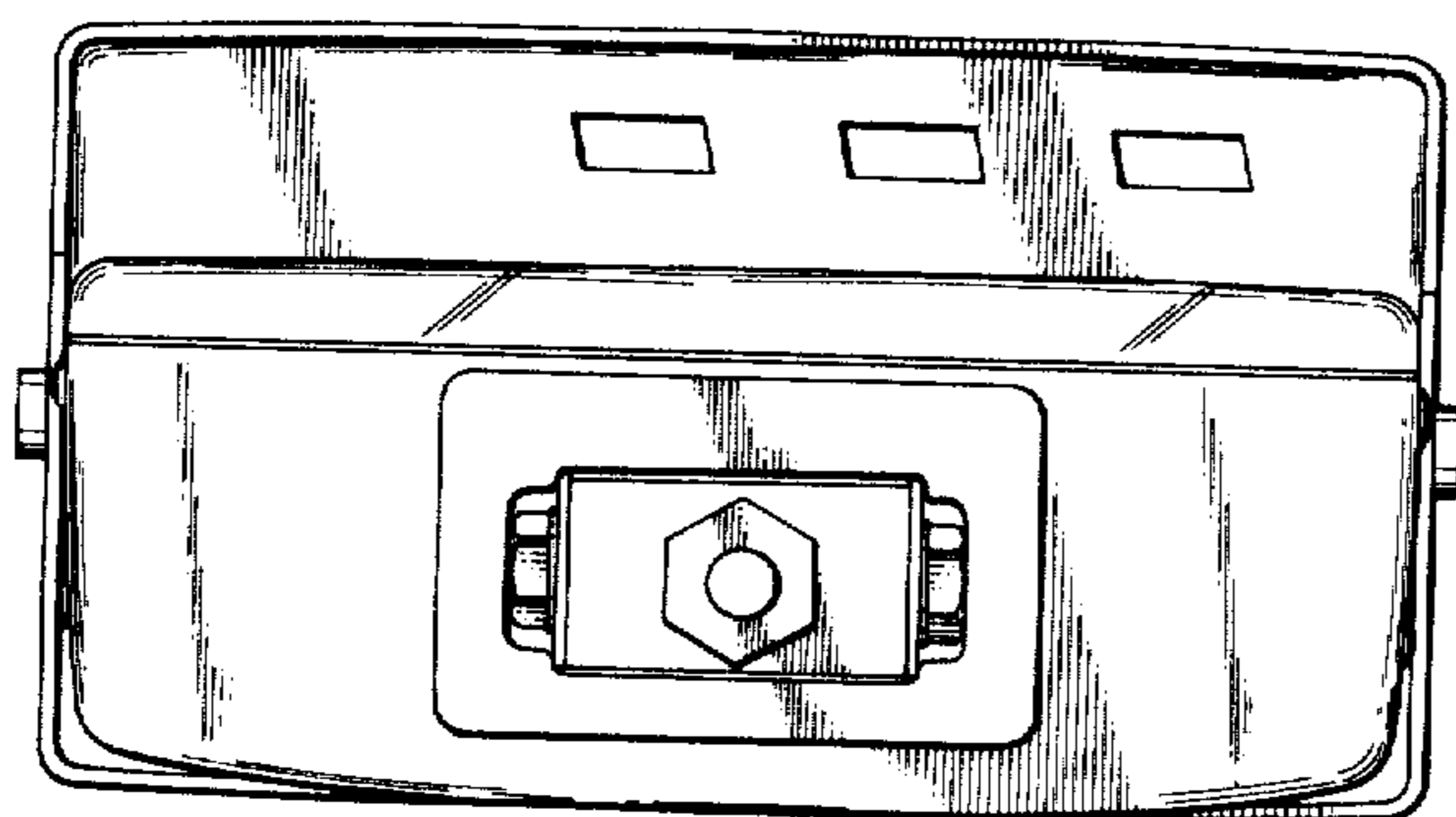

FIG. 5

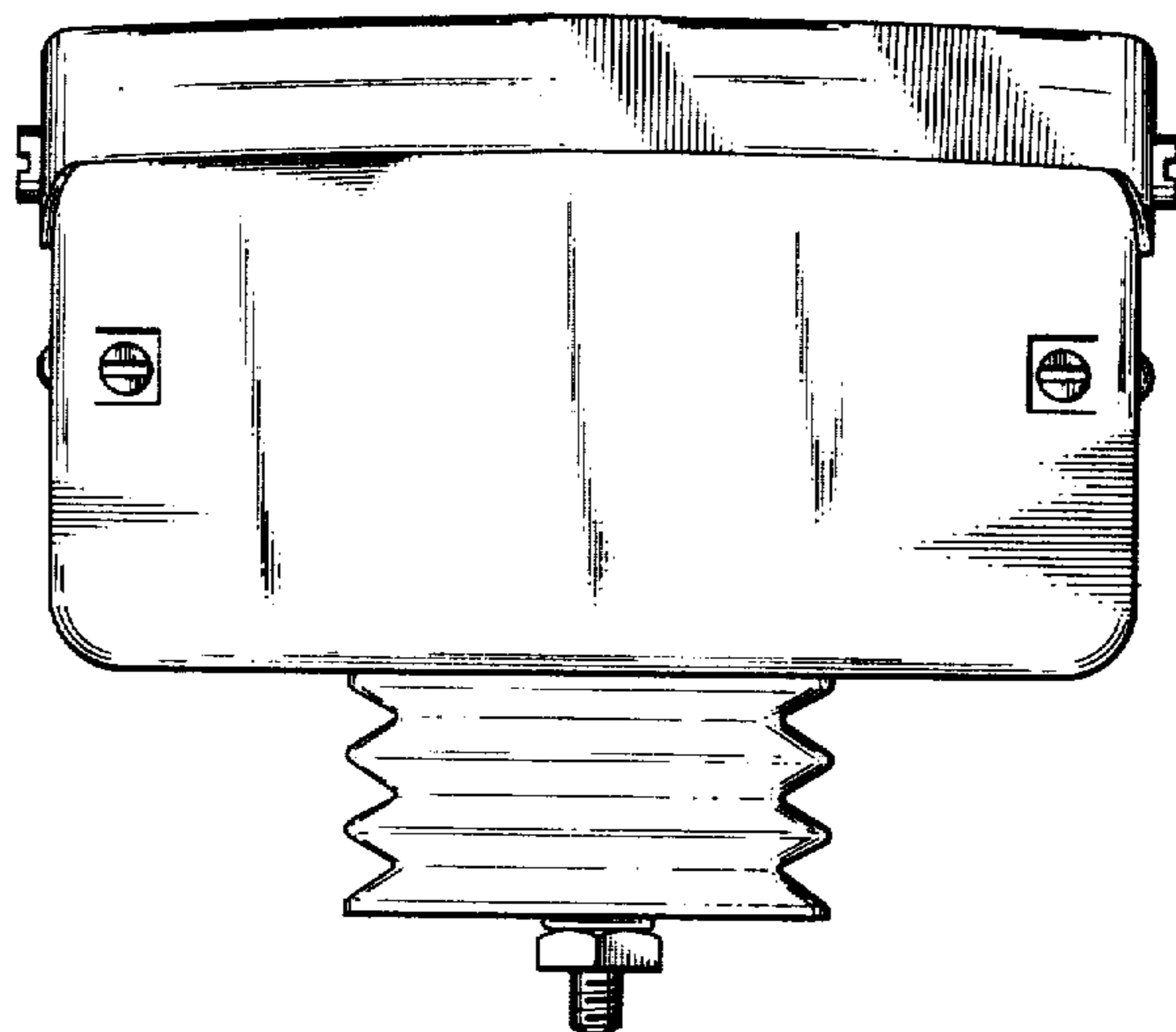

FIG. 6

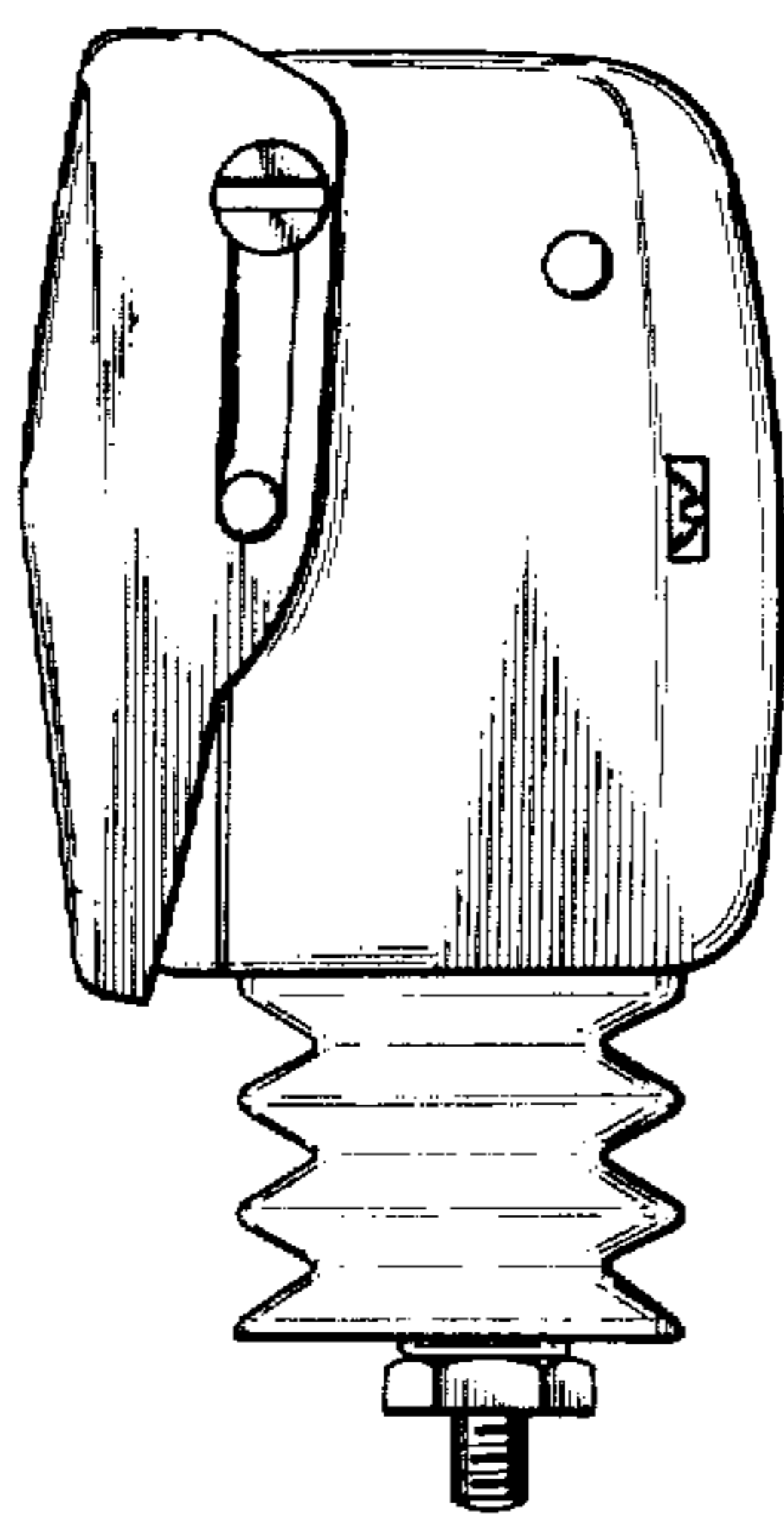

FIG. 7



FIG. 8

