

[54] LOG CART

[75] Inventor: Dudley K. Flanders, Fort Smith, Ark.

[73] Assignee: Flanders Industries, Inc., Fort Smith, Ark.

[**] Term: 14 Years

[21] Appl. No.: 245,380

[22] Filed: Mar. 19, 1981

[51] Int. Cl. D12-02

[52] U.S. Cl. D34/26; D34/24

[58] Field of Search D34/26, 24; D7/212;
280/47.13, 47.17, 47.23, 47.24, 47.26, 47.27,
47.28, 47.18; 211/60 R

[56] References Cited

U.S. PATENT DOCUMENTS

- D. 174,321 3/1955 Haynes, Sr. D34/24
- D. 184,752 3/1959 McVey D7/212
- D. 212,600 11/1968 Bequette, Jr. D34/24

FOREIGN PATENT DOCUMENTS

1106287 7/1955 France 280/47.24

OTHER PUBLICATIONS

New Hampton General Store Spring 1980 Catalog, p. 41, Log Tram, item F, center of page.

Primary Examiner—James M. Gandy
Attorney, Agent, or Firm—Orrin M. Haugen; Thomas J. Nikolai

[57] CLAIM

The ornamental design for a log cart, substantially as shown.

DESCRIPTION

FIG. 1 is a perspective view of the log cart of the present invention;
FIG. 2 is a front elevational view thereof;
FIG. 3 is a side elevational view thereof;
FIG. 4 is a rear elevational view thereof;
FIG. 5 is a top plan view thereof;
FIG. 6 is a bottom plan view thereof; and
FIG. 7 is a perspective view thereof in exploded condition.

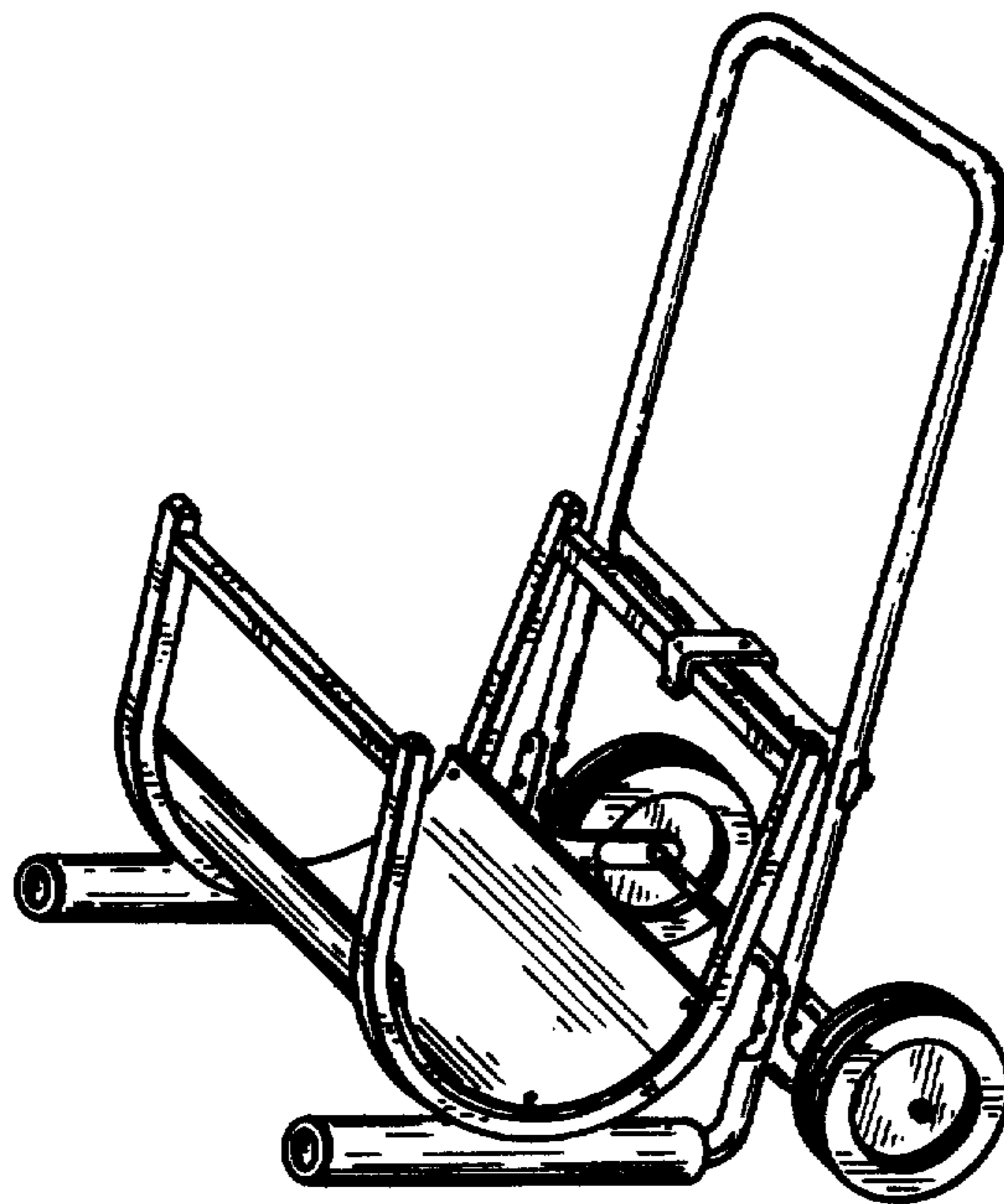

Fig. 1

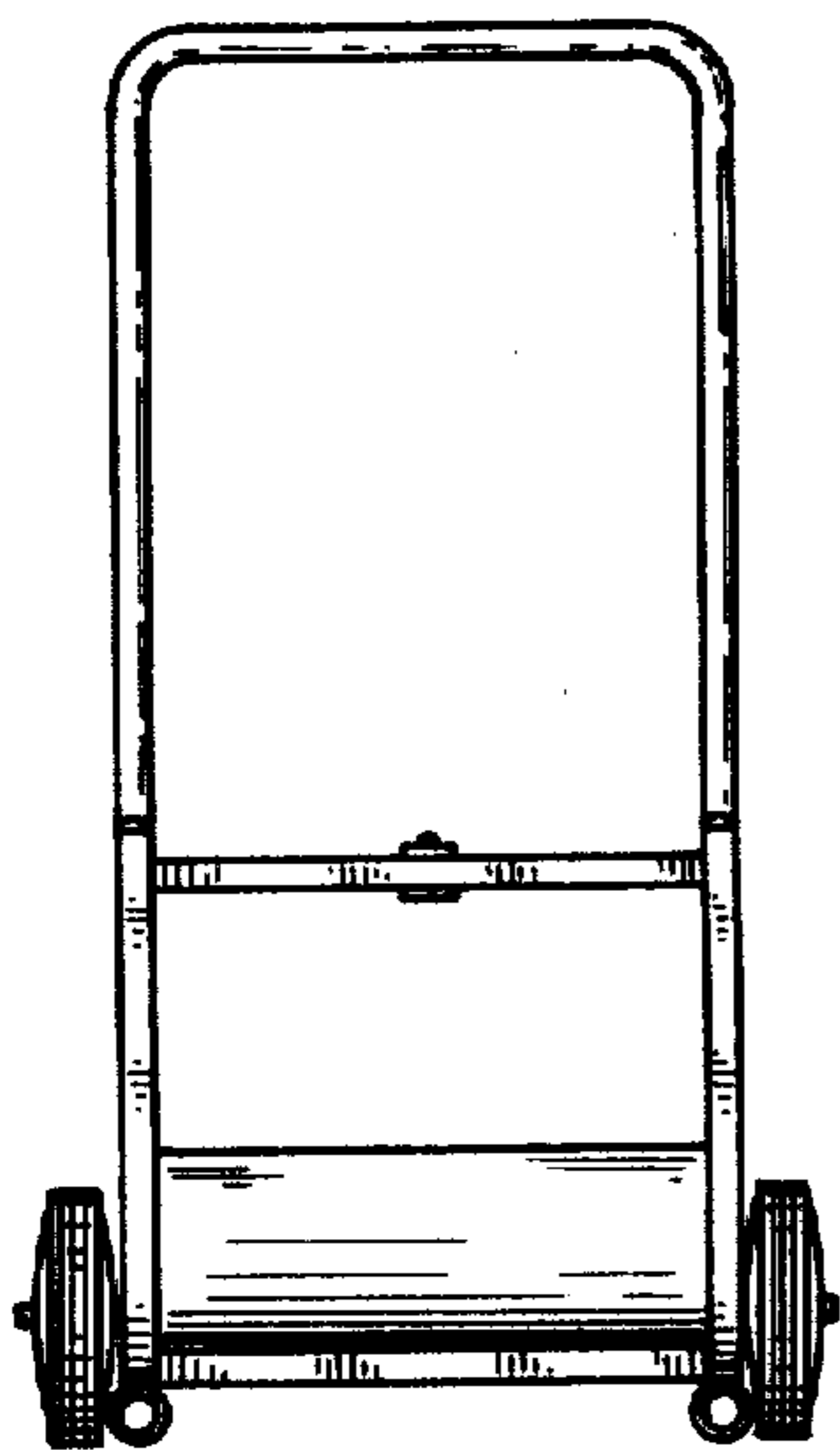
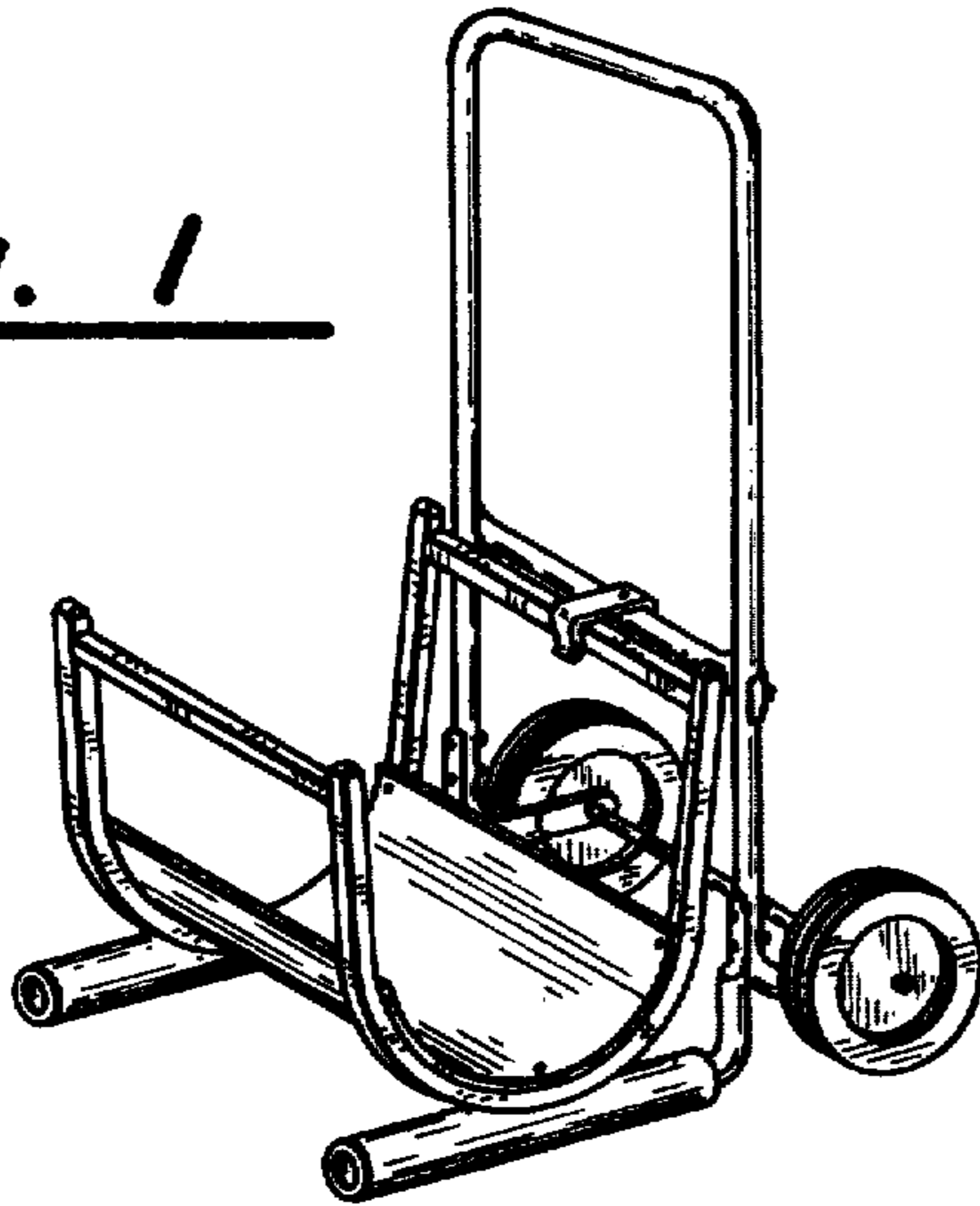

Fig. 2

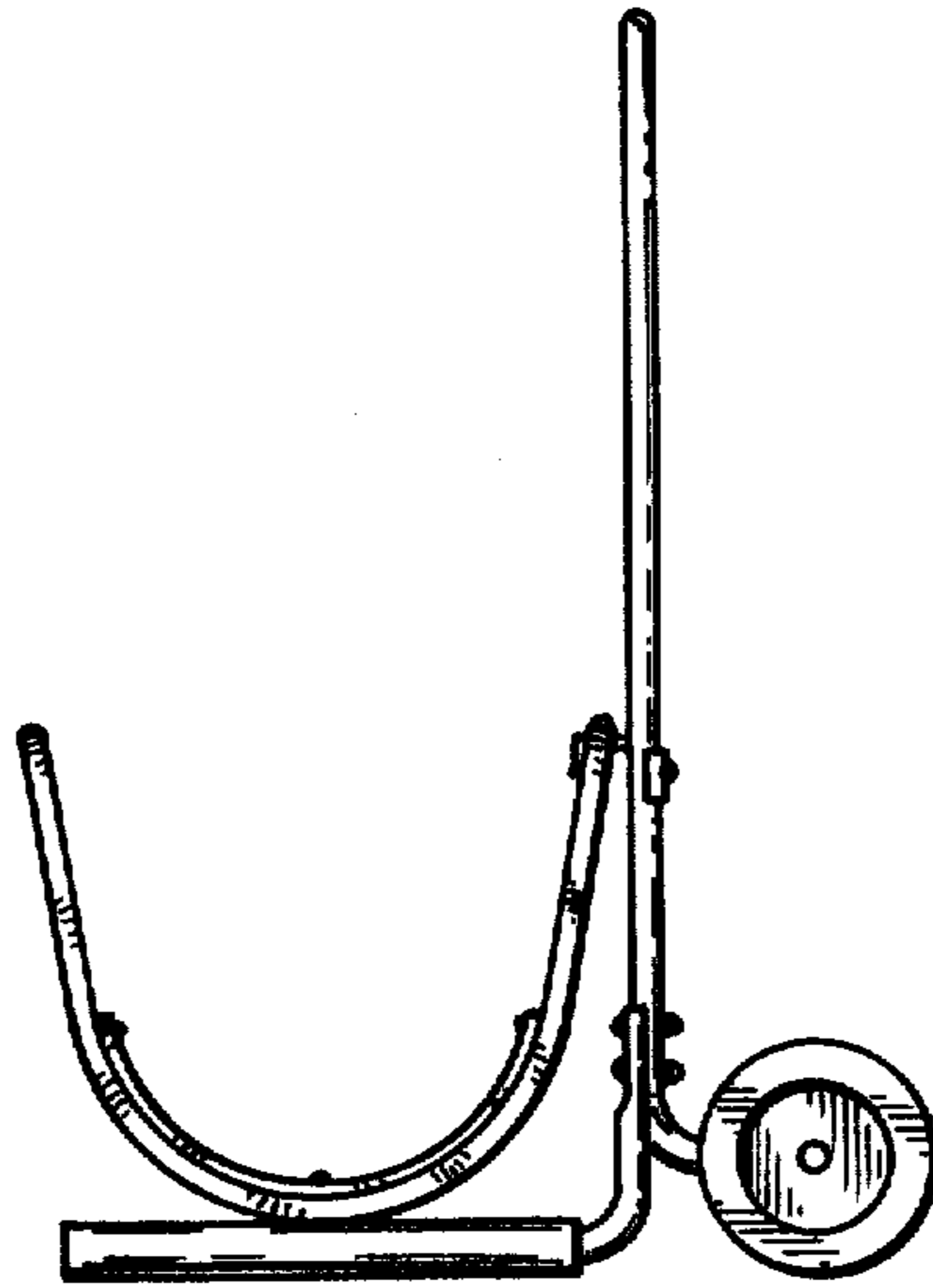

Fig. 3

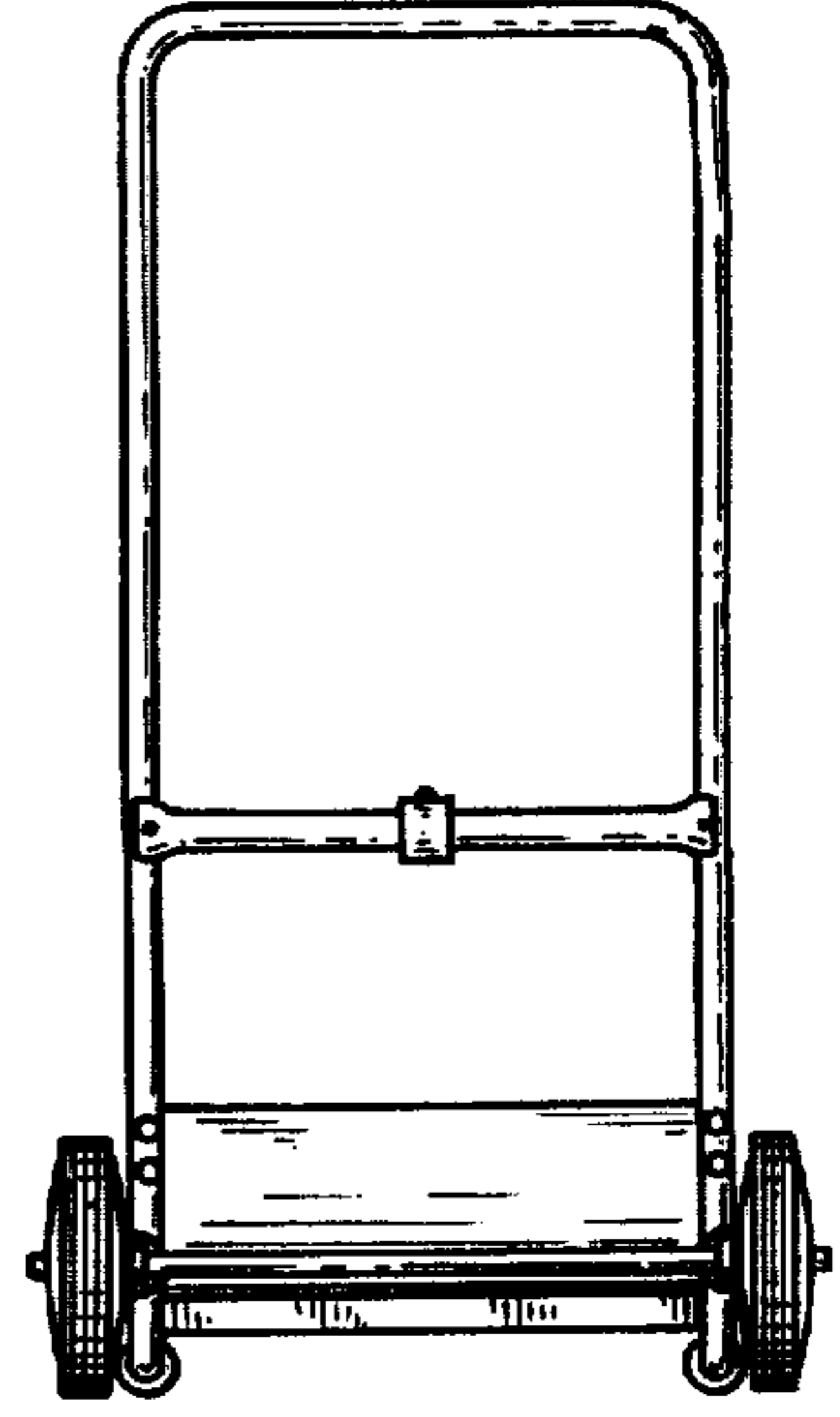

Fig. 4

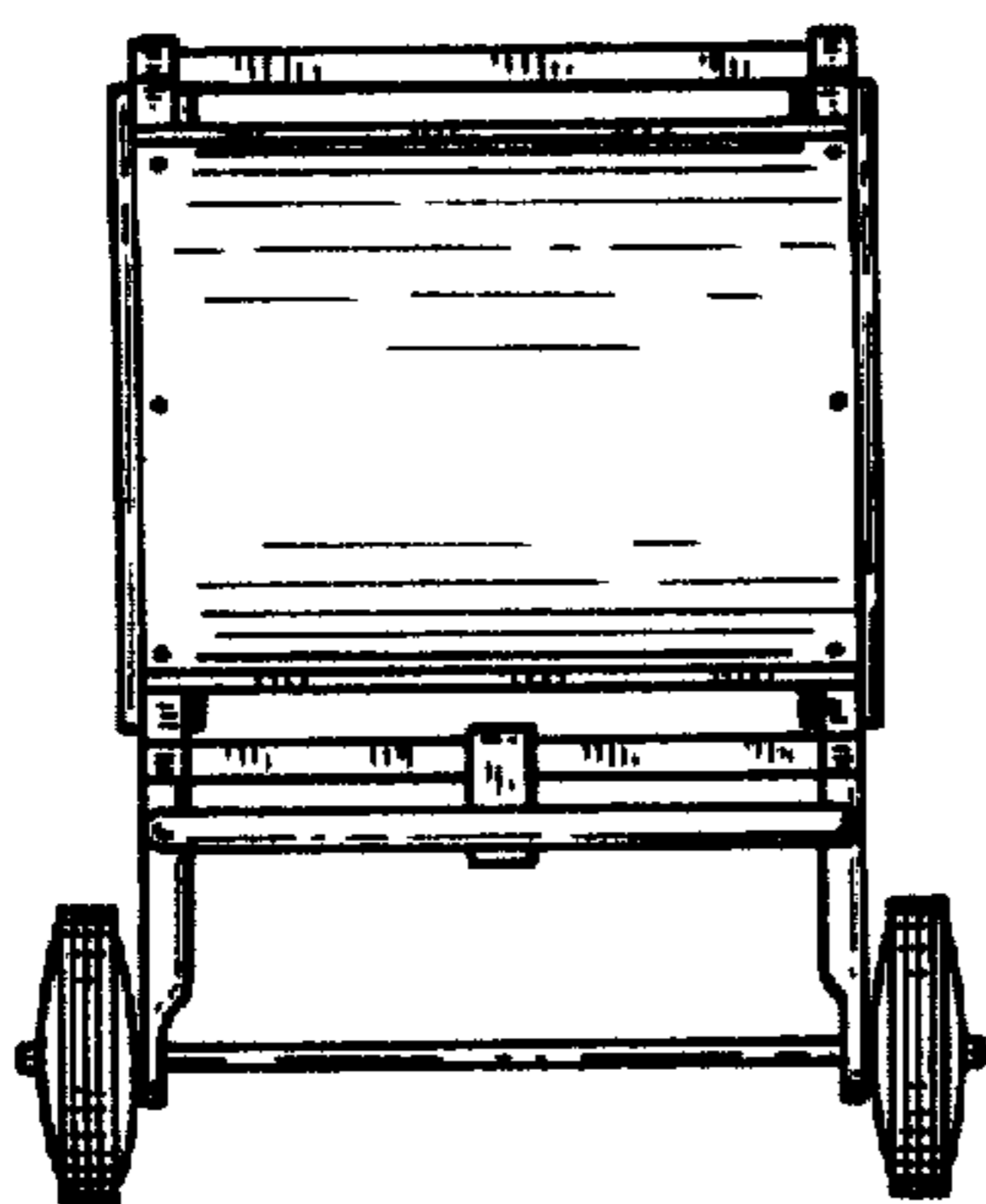

Fig. 5

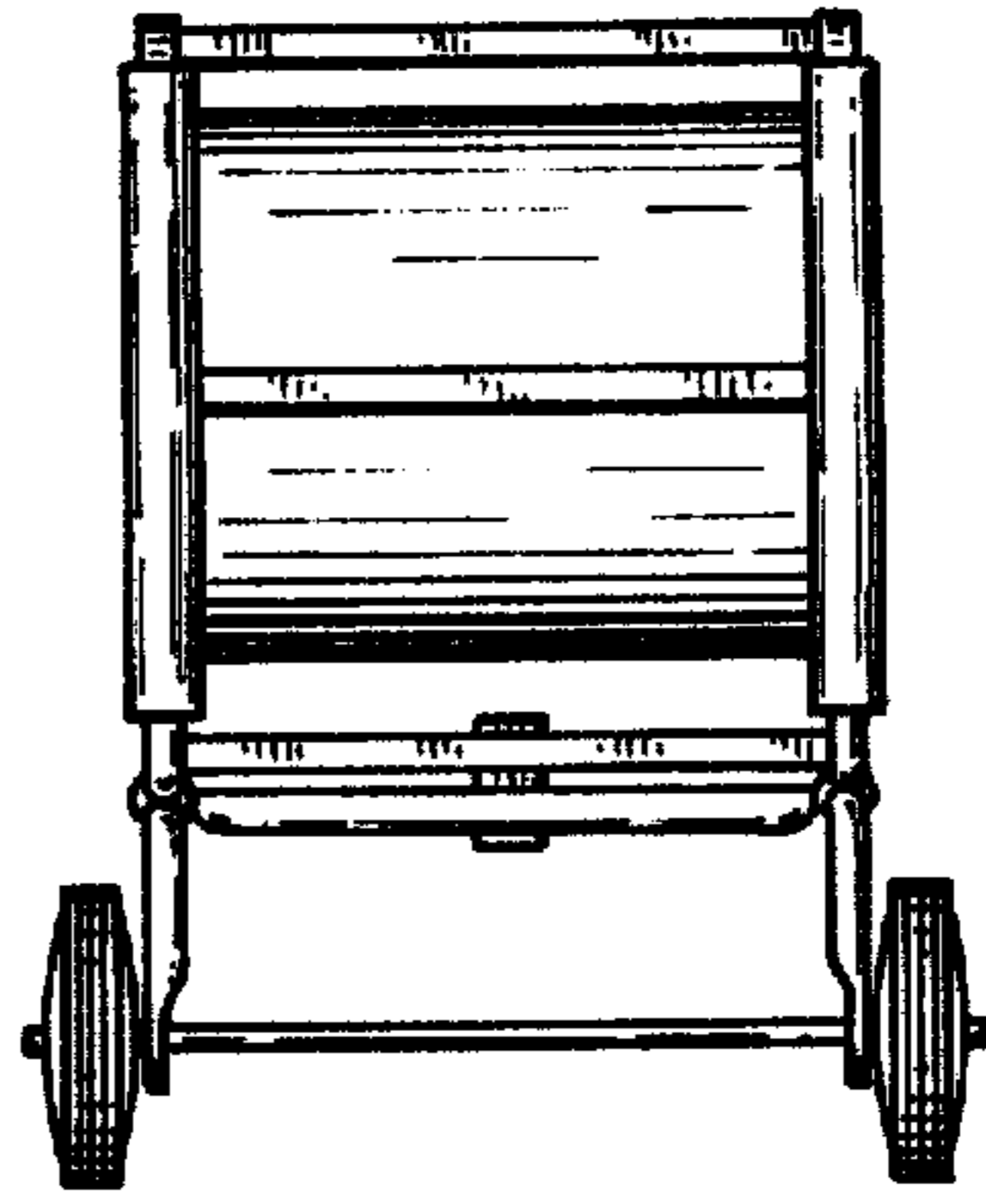

Fig. 6

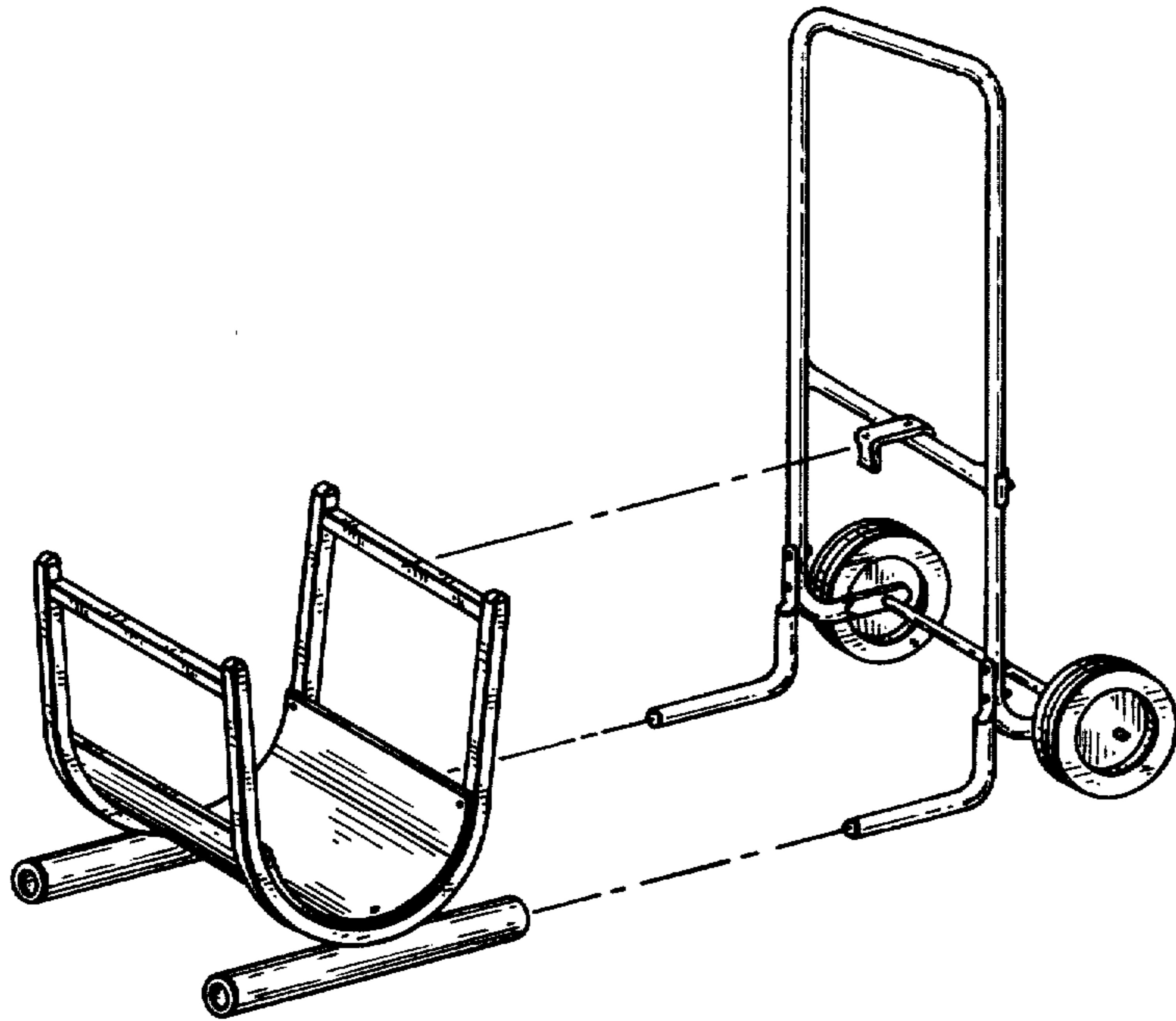

Fig. 7