

[54] TOY DRAGSTER

[75] Inventor: Steven E. Hilko, East Aurora, N.Y.

[73] Assignee: The Quaker Oats Company, Chicago, Ill.

[**] Term: 14 Years

[21] Appl. No.: 216,265

[22] Filed: Dec. 15, 1980

[51] Int. Cl. D21-01
[52] U.S. Cl. D21/137
[58] Field of Search D21/124, 128, 132, 134, D21/135-137, 140, 76, 79, 81; 46/103, 105, 201, 202, 204, 206, 210, 211, 212, 213; 280/87.01, 87.02 R

[56] References Cited

U.S. PATENT DOCUMENTS

D. 219,525 12/1970 Tauranac D21/137
D. 223,542 5/1972 Terry D21/137
D. 227,385 6/1973 Wood D21/137

OTHER PUBLICATIONS

Road & Track Catalog, 1972-1973 Catalog, p. 9, "JA 943A Matra V8 F.1" Vehicle.

Primary Examiner—Charles A. Rademaker
Attorney, Agent, or Firm—Cumpston & Shaw

[57] CLAIM

The ornamental design for a toy dragster, substantially as shown.

DESCRIPTION

FIG. 1 is a right-side perspective view of a toy dragster showing my new design;
FIG. 2 is a top plan view thereof;
FIG. 3 is a left-side elevational view thereof;
FIG. 4 is a rear elevational view thereof; and
FIG. 5 is a bottom plan view thereof.

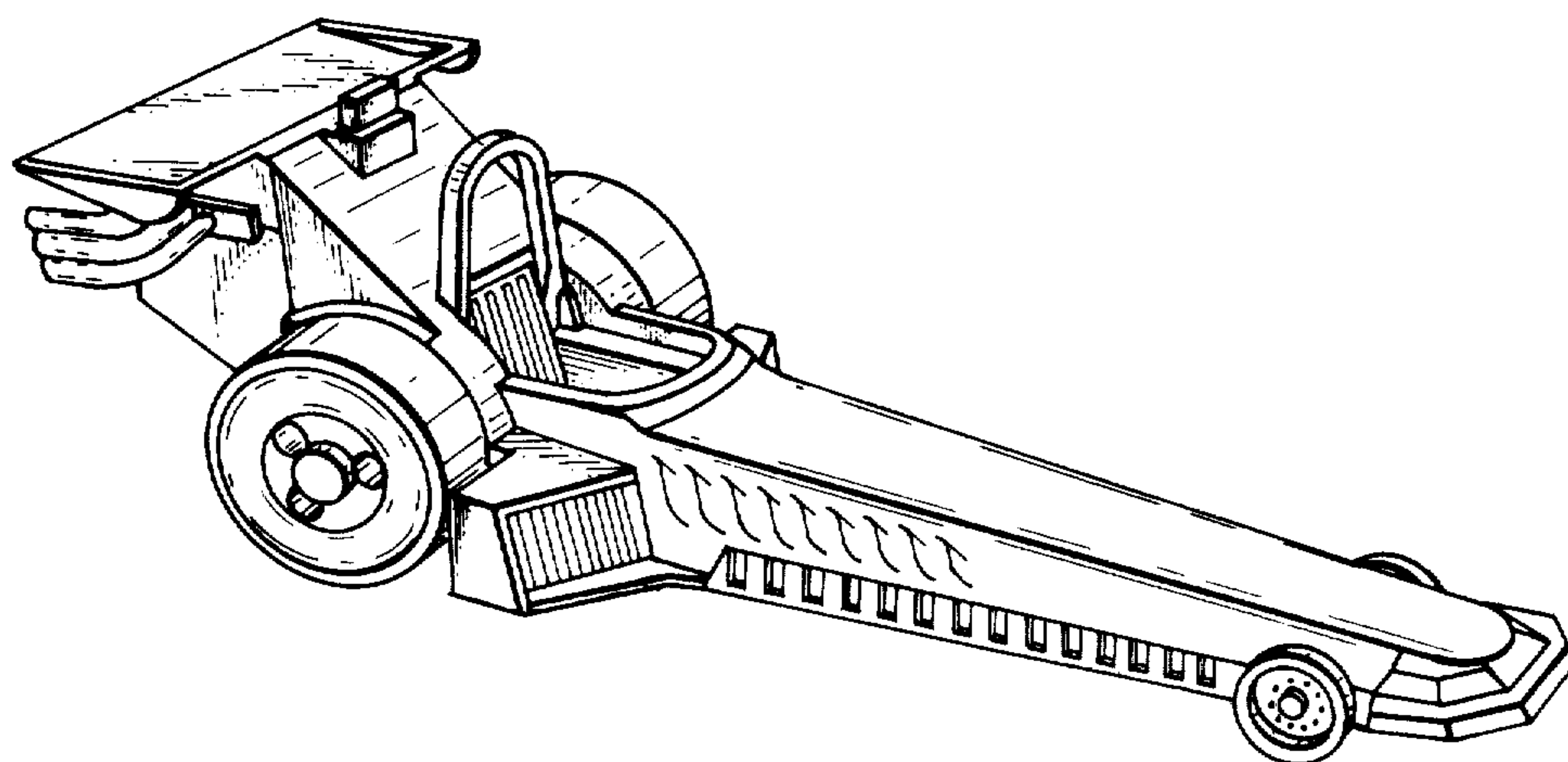

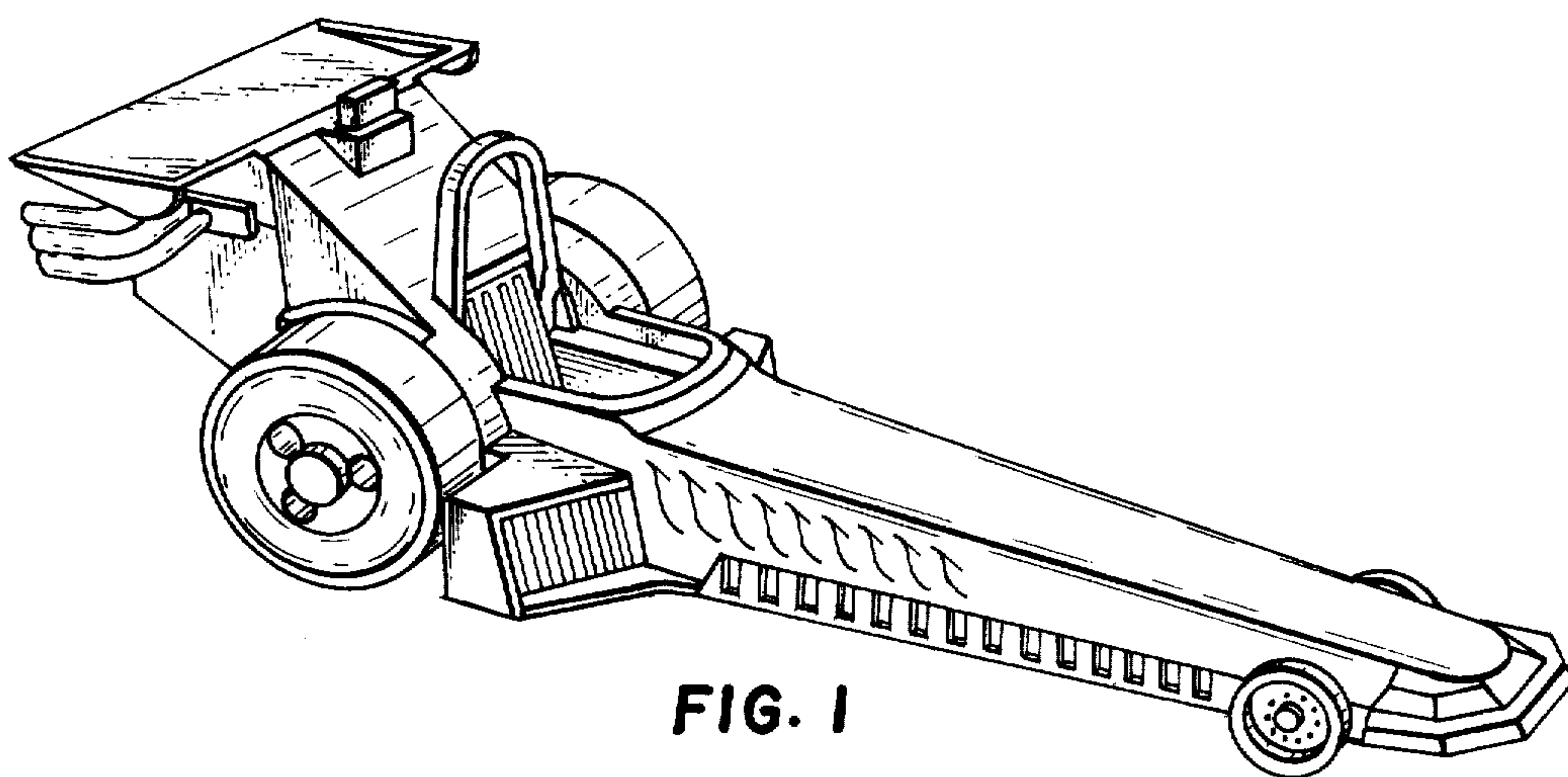

FIG. 1

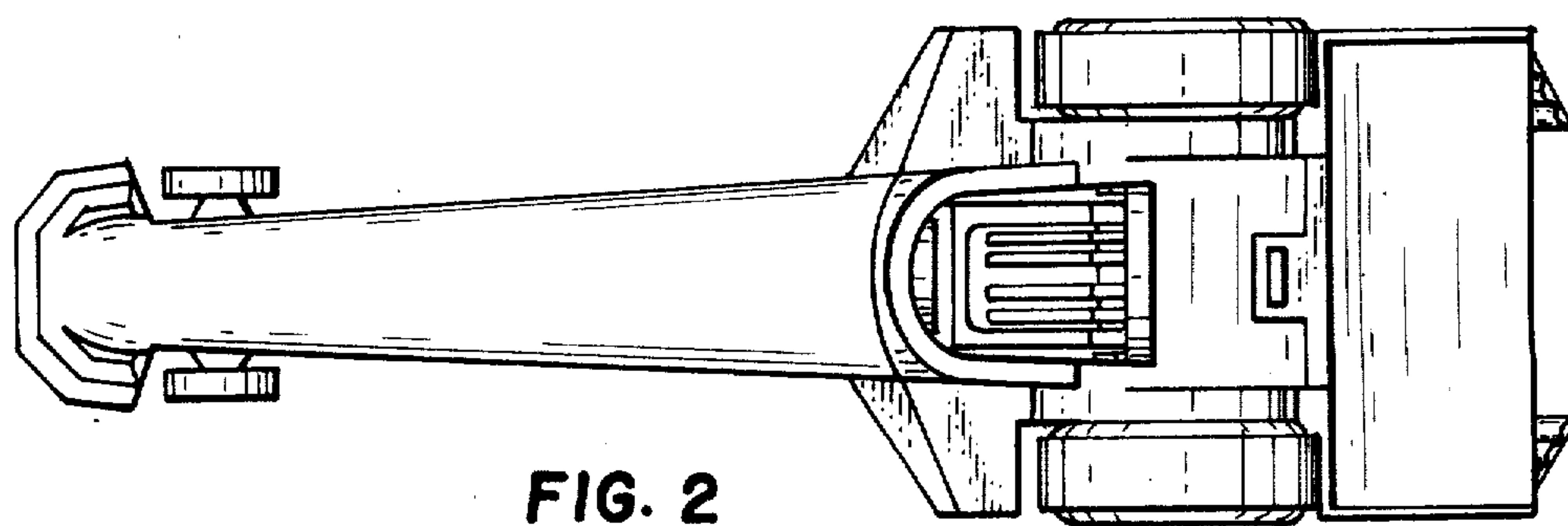

FIG. 2

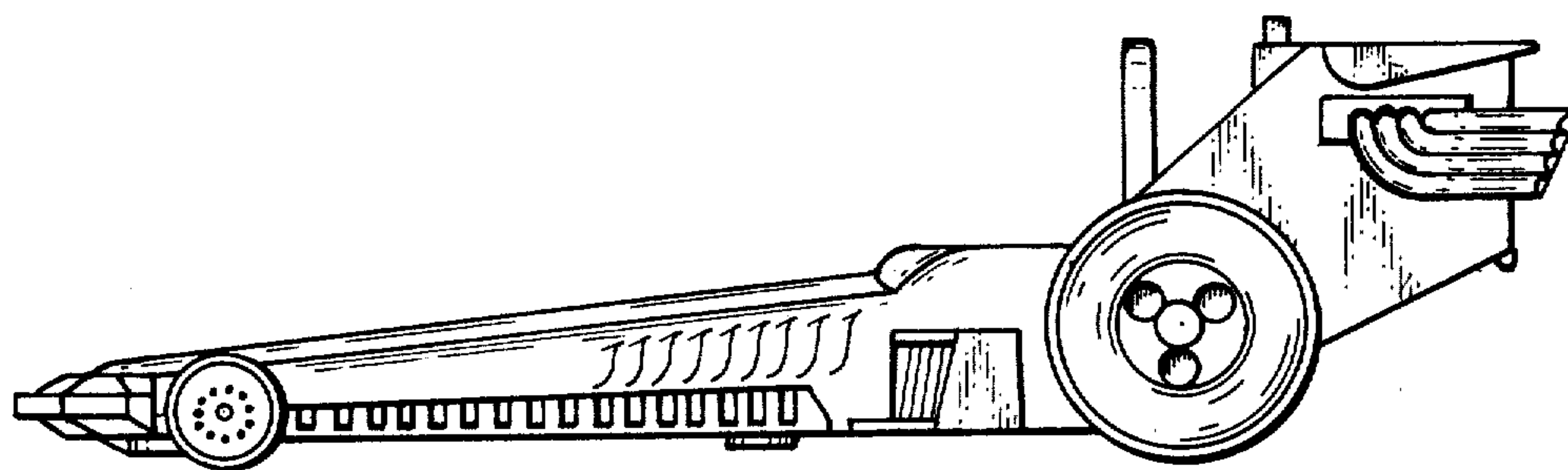

FIG. 3

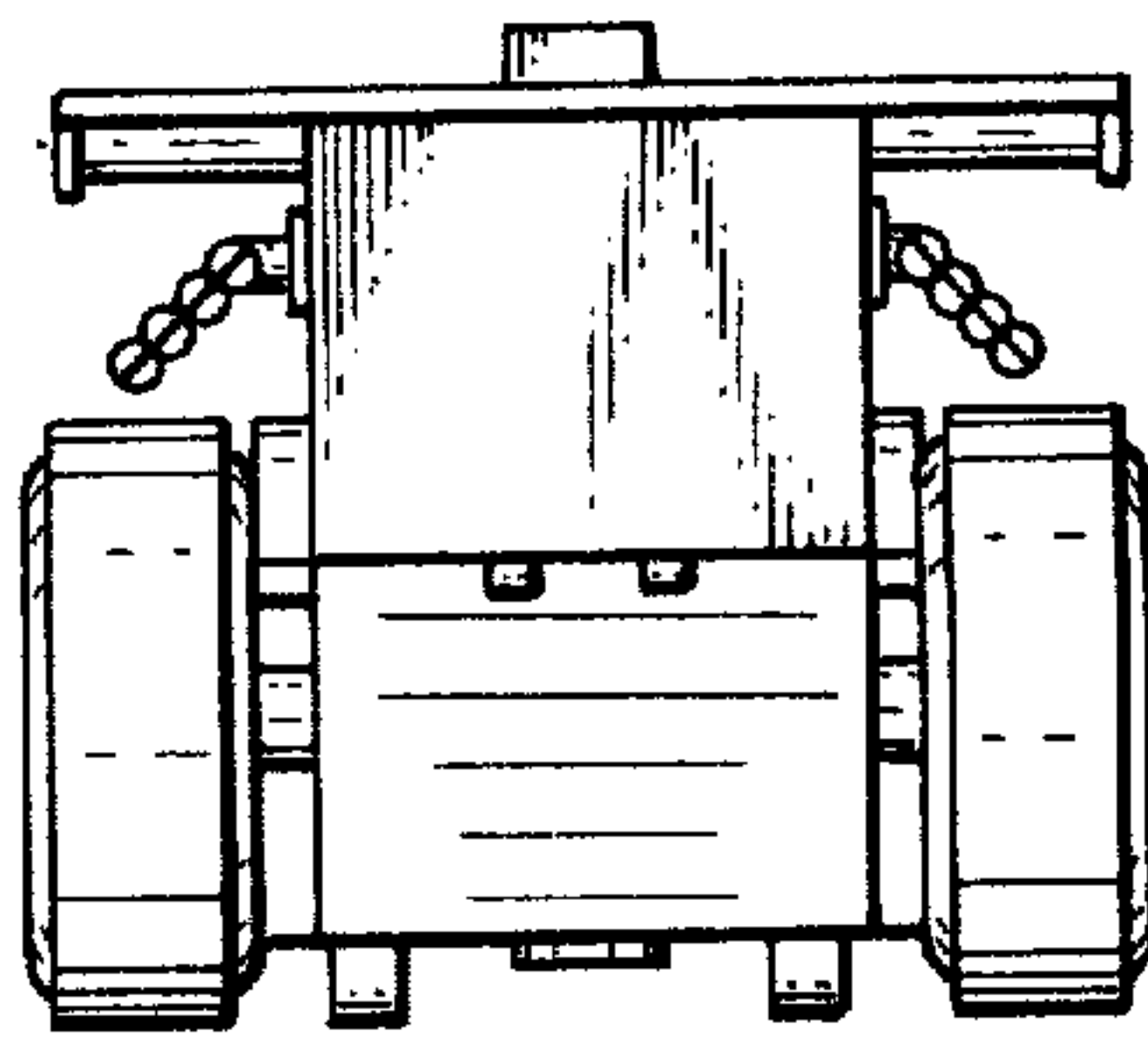

FIG. 4

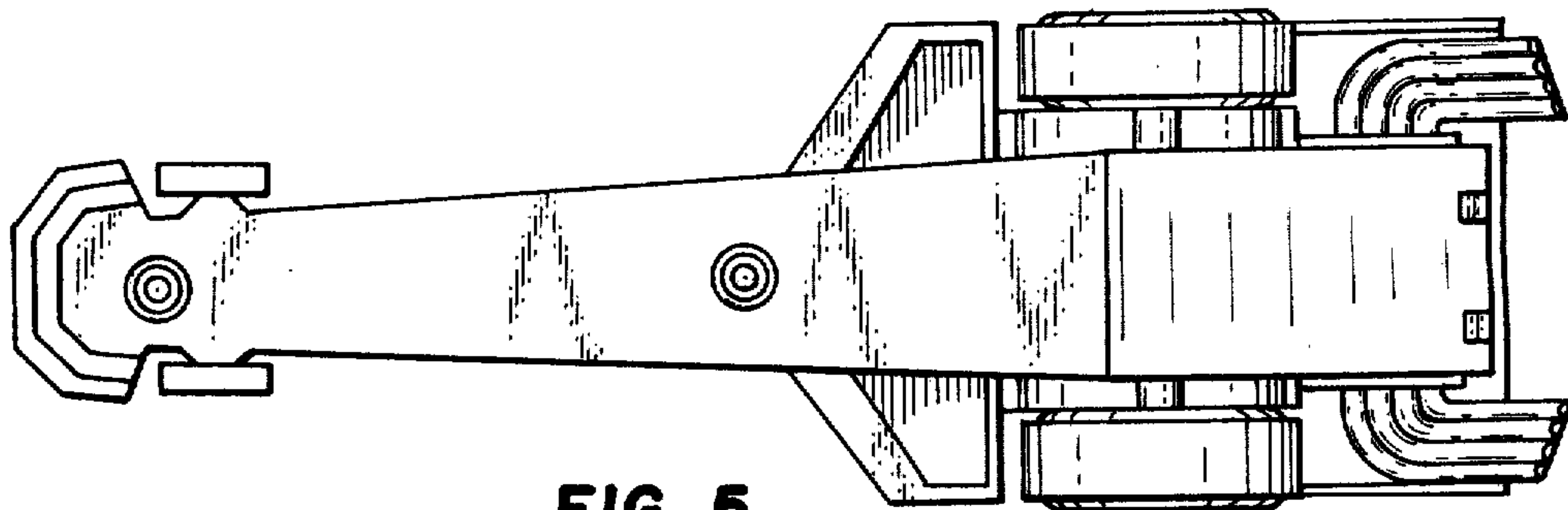

FIG. 5