

[54] MINIATURE LAMPHOLDER

[75] Inventor: David Partridge, West Wickham,
England

[73] Assignee: Starpoint Electrics Limited, Surrey,
England

[**] Term: 14 Years

[21] Appl. No.: 133,449

[22] Filed: Mar. 24, 1980

[30] Foreign Application Priority Data
Oct. 1, 1979 [GB] United Kingdom 991791

[51] Int. Cl. D13-03
[52] U.S. Cl. D13/25
[58] Field of Search D13/25; 339/59 L, 61 L,
339/97 L, 99 L, 119 L, 125 L, 144 R, 176 L,
191 L, 195 L, 128; 362/396

[56] References Cited

U.S. PATENT DOCUMENTS

D. 203,503 1/1966 Dell D13/25
3,366,727 1/1968 Rueger 339/128 X
3,614,713 10/1971 Heath 339/128
4,114,972 9/1978 Kraus et al. 339/176 L X

FOREIGN PATENT DOCUMENTS

1323601 7/1973 United Kingdom 339/128

Primary Examiner—Susan J. Lucas
Attorney, Agent, or Firm—Larson & Taylor

[57] CLAIM

The ornamental design for a miniature lampholder, as shown.

DESCRIPTION

FIG. 1 is a perspective view from one side and one end of the miniature lampholder showing my new design; FIG. 2 is a perspective view from the other side and other end thereof; FIG. 3 is a side view thereof. FIG. 4 is a right hand end elevational view thereof.

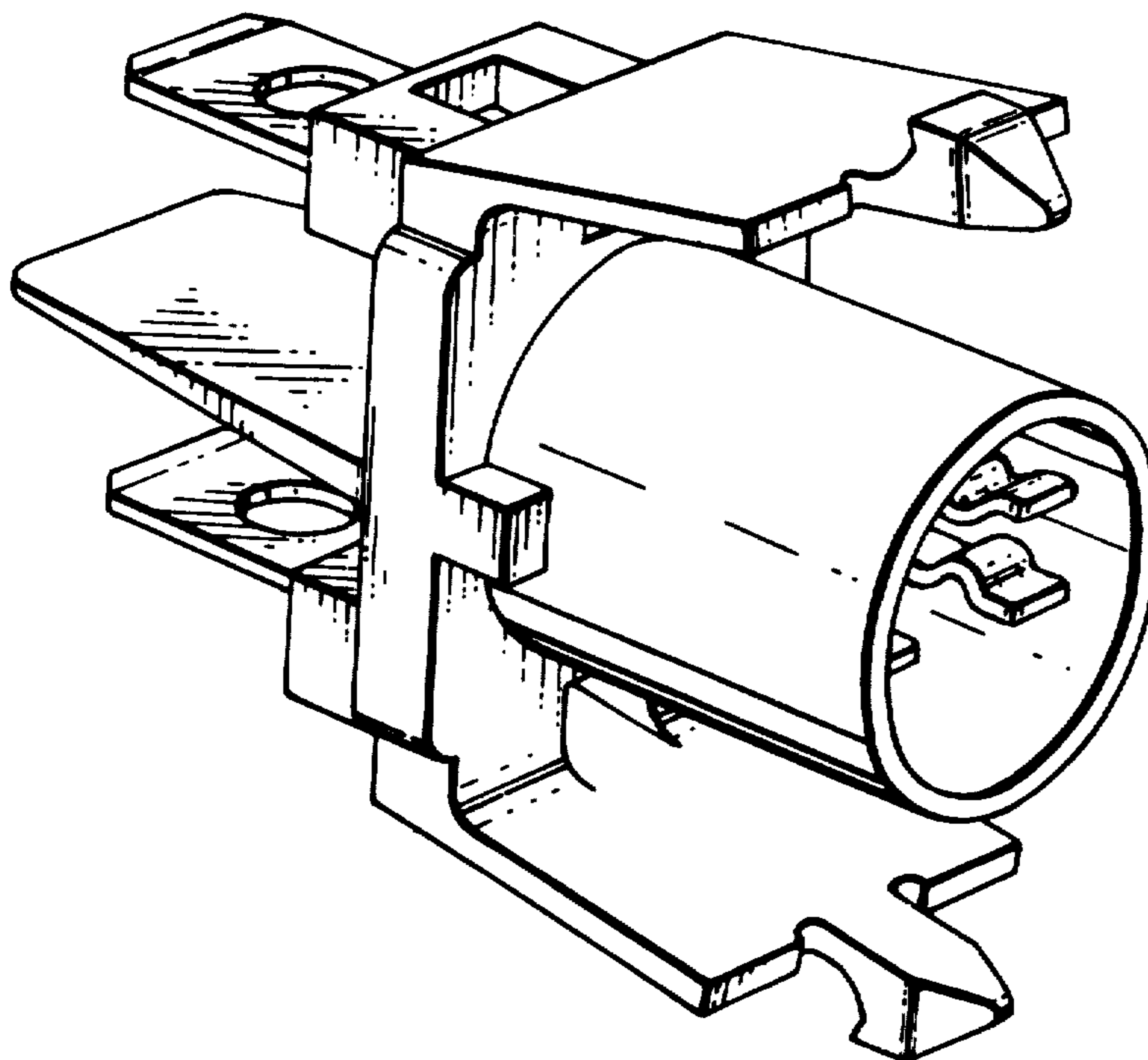

Fig. 1.

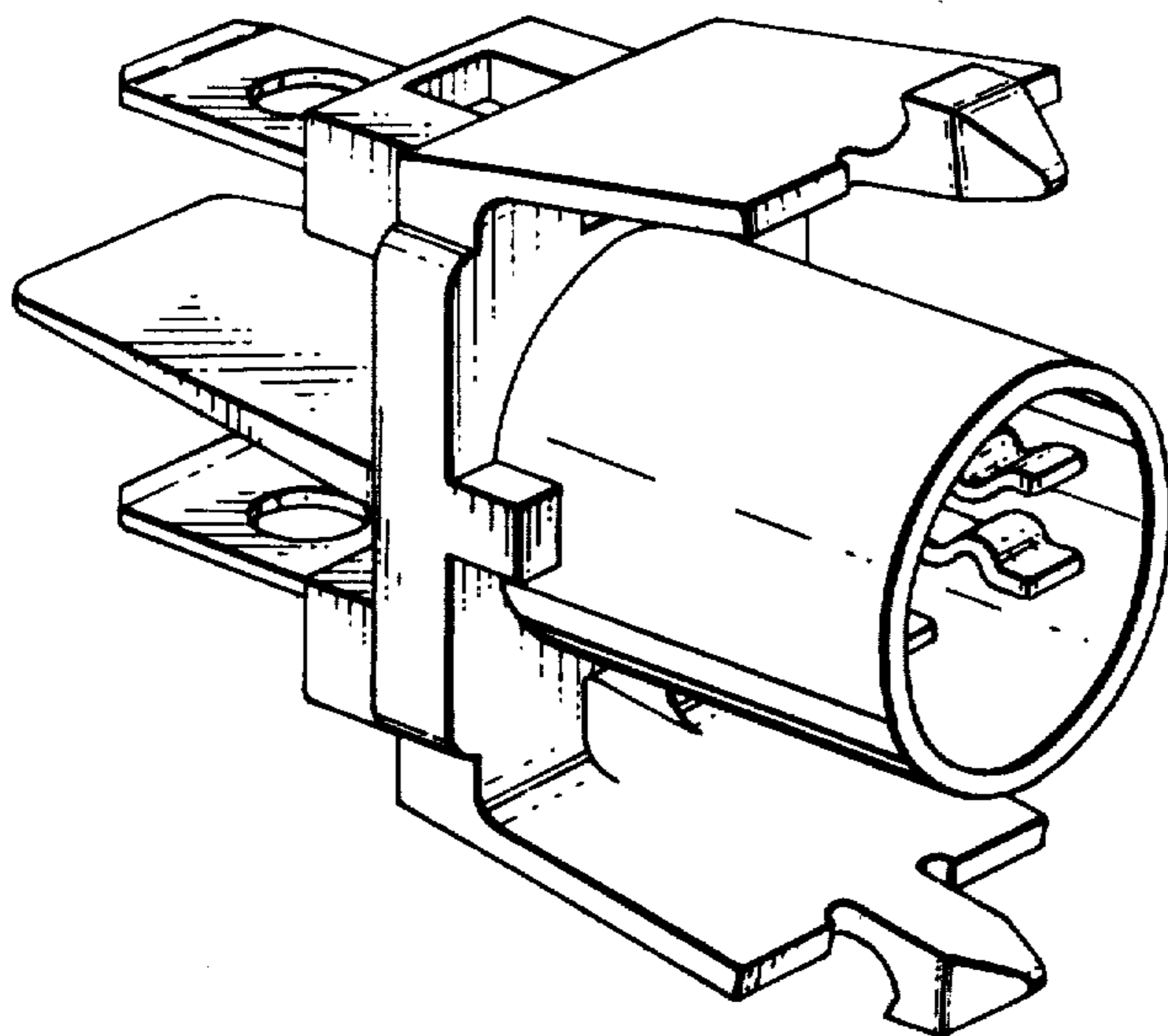

Fig. 2.

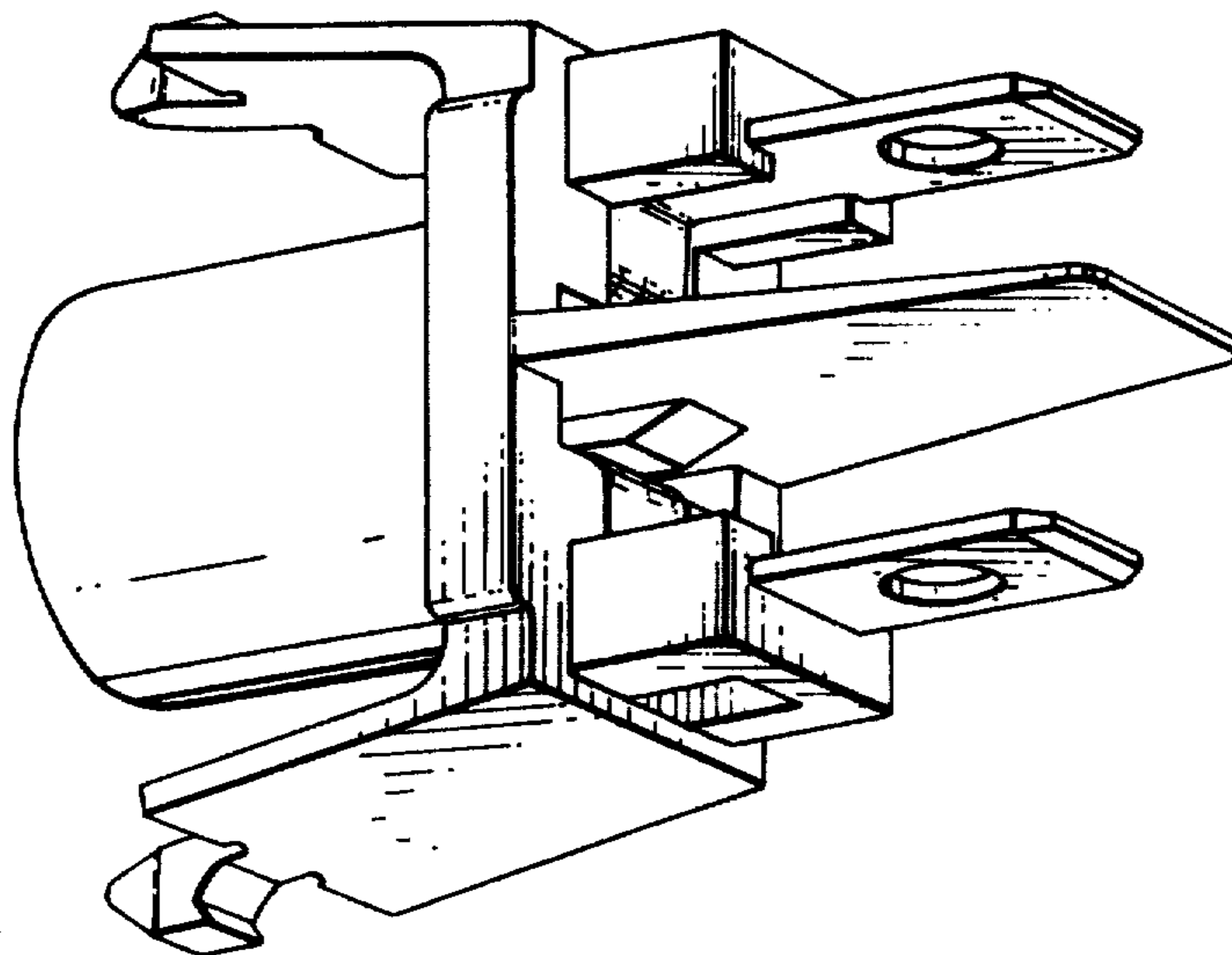

Fig. 3.

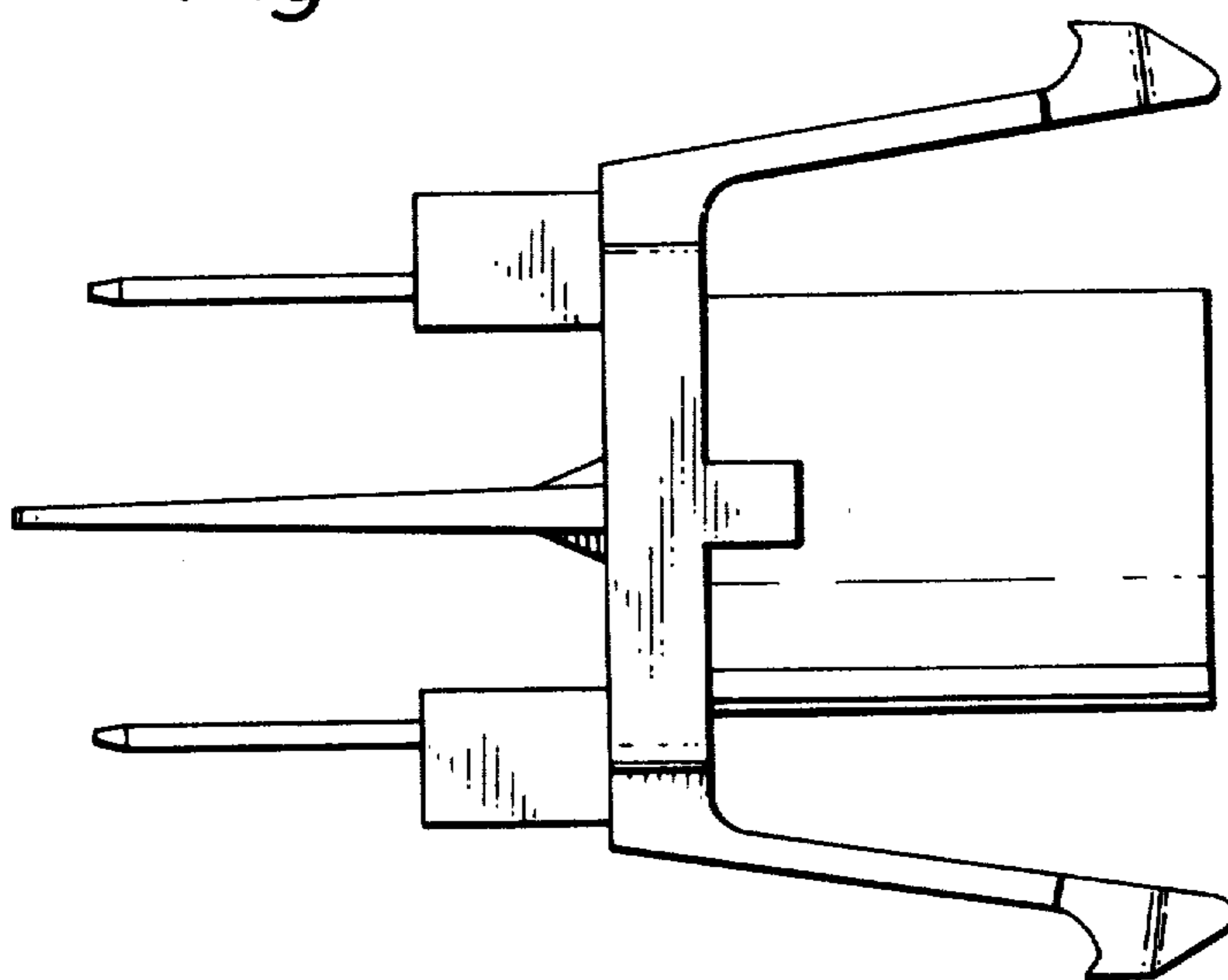

Fig.4.

