

[54] MOTOR VEHICLE JACK

[75] Inventor: **Graham H. Colton**, Rise Park, England

[73] Assignee: **Metallifactory Limited**, Redhill, England

[\*\*] Term: **14 Years**

[21] Appl. No.: **101,430**

[22] Filed: **Dec. 10, 1979**

[51] Int. Cl. .... **D12-05**

[52] U.S. Cl. .... **D34/31**

[58] Field of Search ..... **D12/55; 254/86 R, 85, 254/13**

[56] **References Cited**

**U.S. PATENT DOCUMENTS**

1,549,810 8/1925 Sauer ..... 254/86 R

3,345,038 10/1967 Taylor ..... 254/86 R  
3,565,396 2/1971 Spear ..... 254/86 R  
4,146,250 3/1979 Den Herder ..... 254/86 R

**FOREIGN PATENT DOCUMENTS**

438214 7/1948 Italy ..... 254/86 R

*Primary Examiner*—James M. Gandy

[57] **CLAIM**

The ornamental design for a motor vehicle jack, substantially as shown and described.

**DESCRIPTION**

FIG. 1 is a side elevational view of a motor vehicle jack showing my new design, the opposite side being substantially a mirror image thereof;

FIG. 2 is a left end elevational view thereof;

FIG. 3 is a right end elevational view thereof; and

FIG. 4 is a sectional view taken along line 4—4 in FIG. 1.

1.

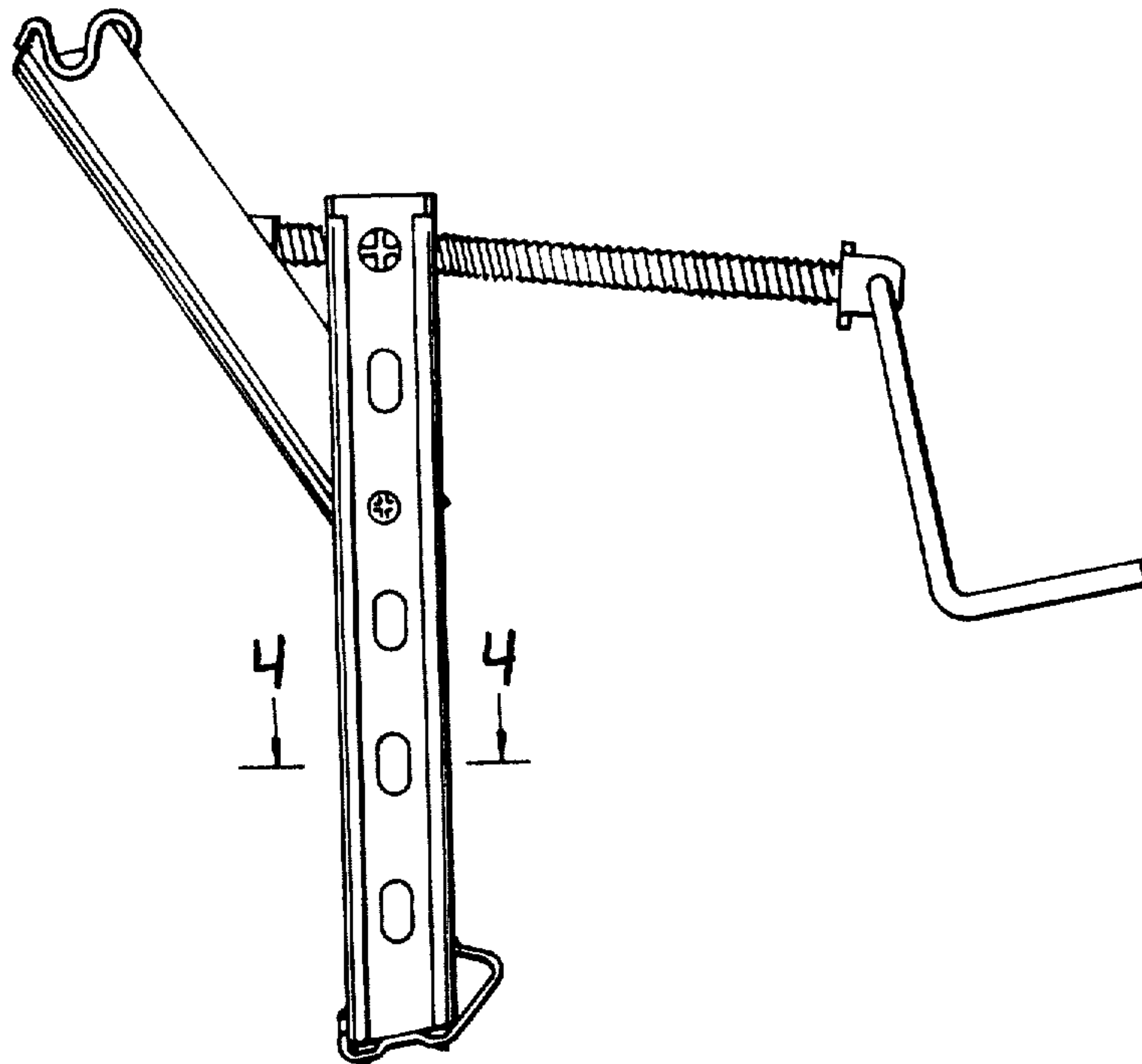

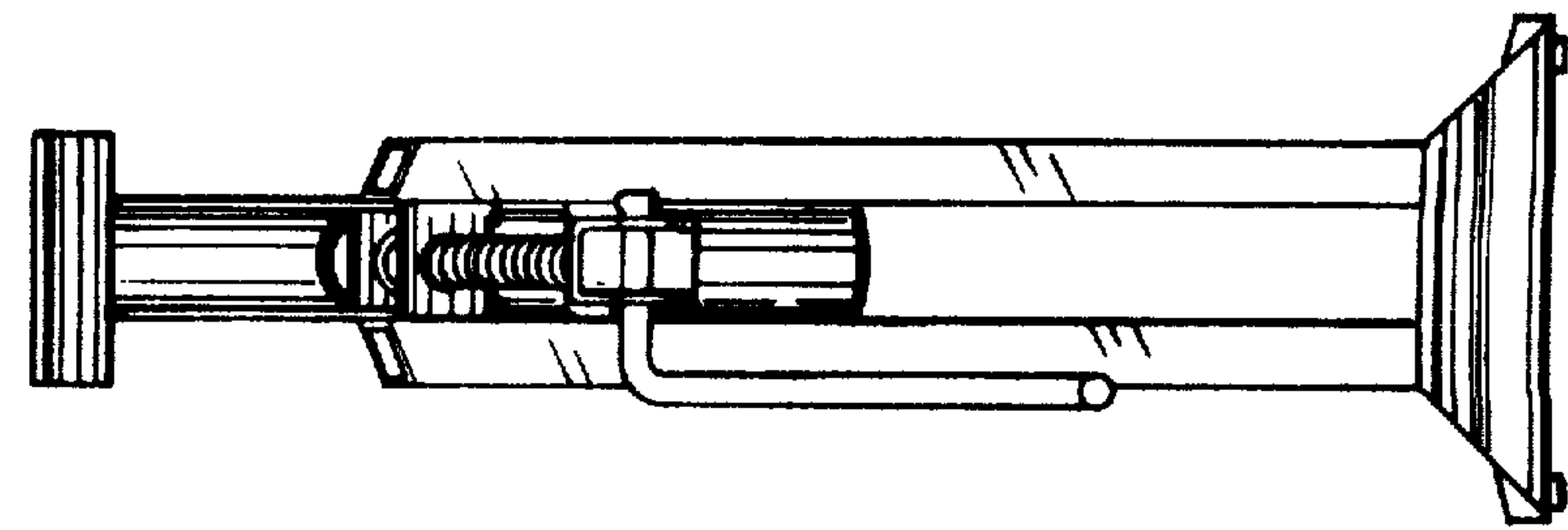

FIG. 3

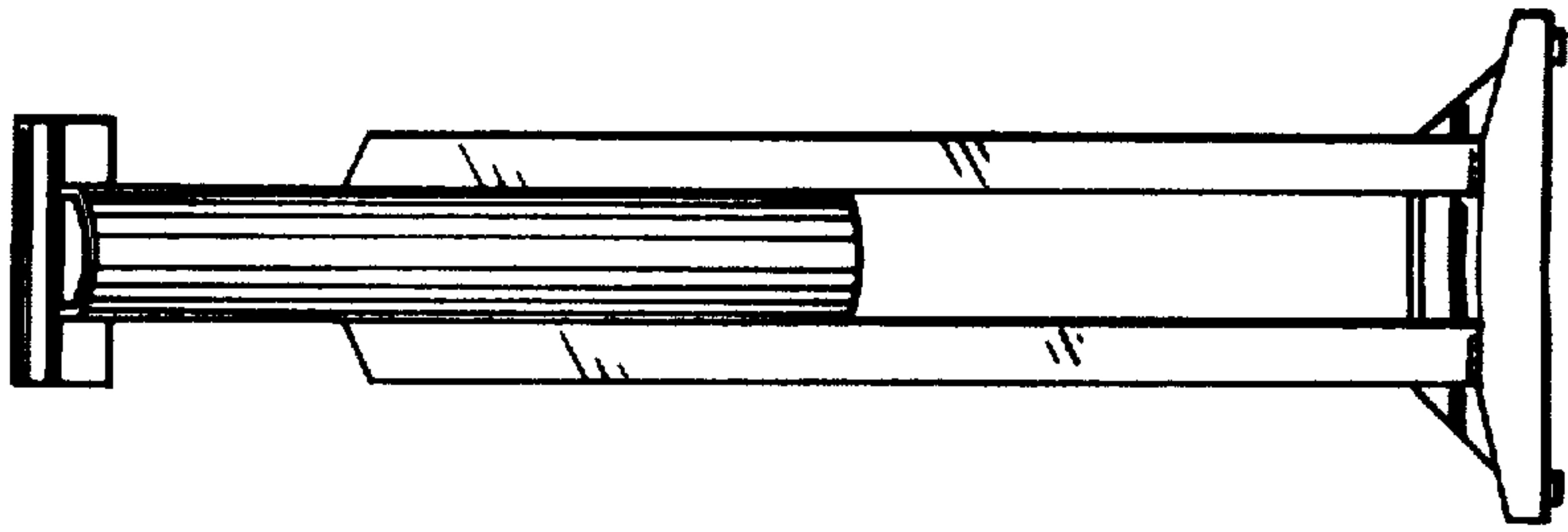

FIG. 2

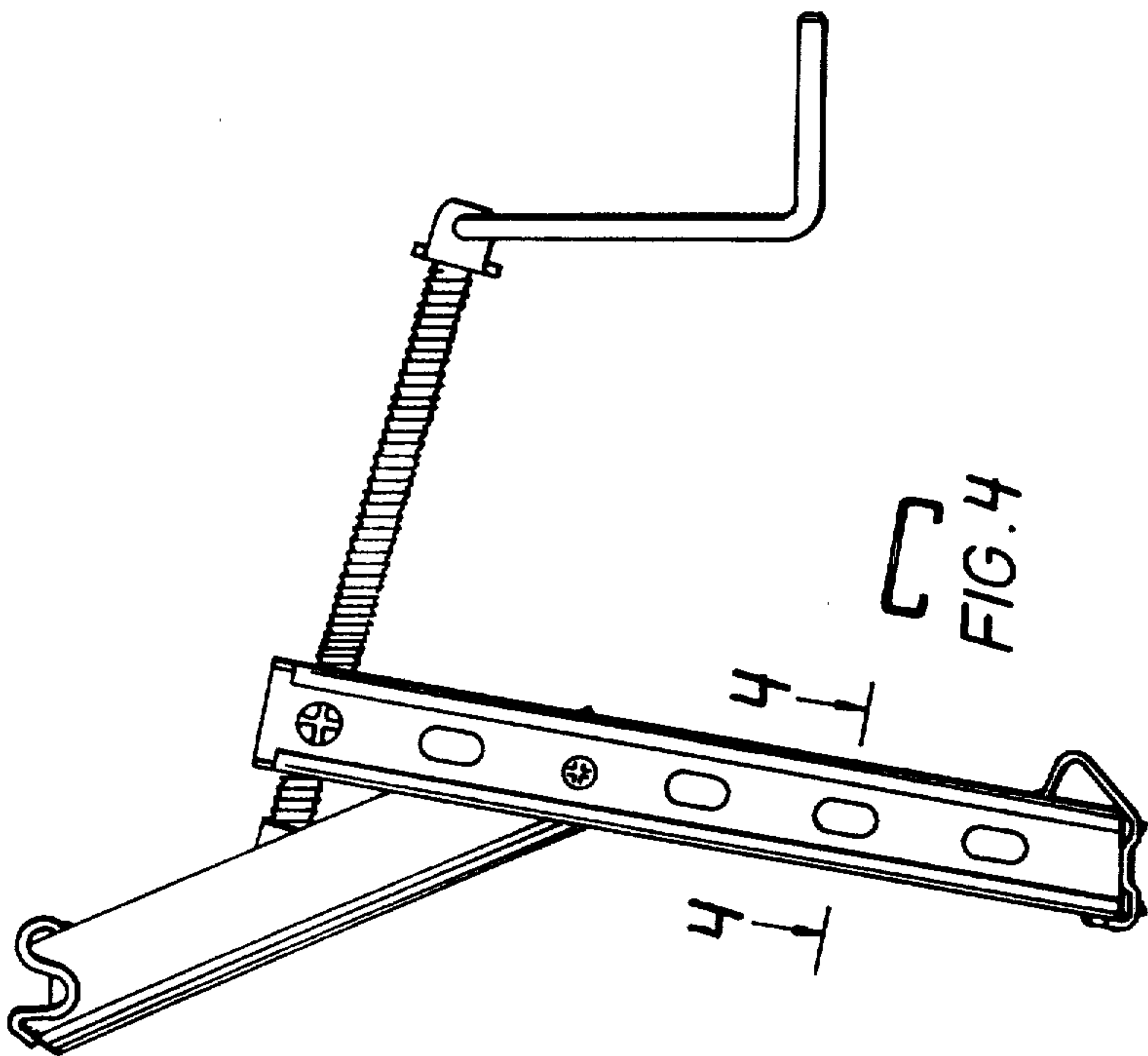

FIG. 1

FIG. 4