

[54] AUTOMOBILE MANIFOLDS

[76] Inventor: Benny Lindbrandt, Tidaholmsvägen 37A, 121 48 Johanneshov, Sweden

[\*\*] Term: 14 Years

[21] Appl. No.: 152,504

[22] Filed: May 22, 1980

[30] Foreign Application Priority Data

Nov. 30, 1979 [SE] Sweden ..... 792642

[51] Int. Cl. .... D15-1

[52] U.S. Cl. .... D15/5

[58] Field of Search ..... D15/5; 123/52 M; 261/DIG. 36

[56] References Cited

U.S. PATENT DOCUMENTS

1,512,961 10/1924 Weil ..... 123/52 M  
4,013,049 3/1977 Dilgard et al. .... D15/5

FOREIGN PATENT DOCUMENTS

473597 10/1937 United Kingdom ..... 123/52 M

Primary Examiner—James M. Gandy  
Attorney, Agent, or Firm—Pasquale A. Razzano

[57] CLAIM

The ornamental design for automobile manifolds, as shown.

DESCRIPTION

FIG. 1 is a top perspective view of an automobile manifold embodying my design;  
FIG. 2 is a bottom perspective view;  
FIG. 3 is a top plan view on a reduced scale;  
FIG. 4 is a right side elevational view on a reduced scale;  
FIG. 5 is a bottom plan view on a reduced scale;  
FIG. 6 is a left side elevational view on a reduced scale;  
FIG. 7 is a front end elevational view on a reduced scale; and  
FIG. 8 is a rear end elevational view on a reduced scale.

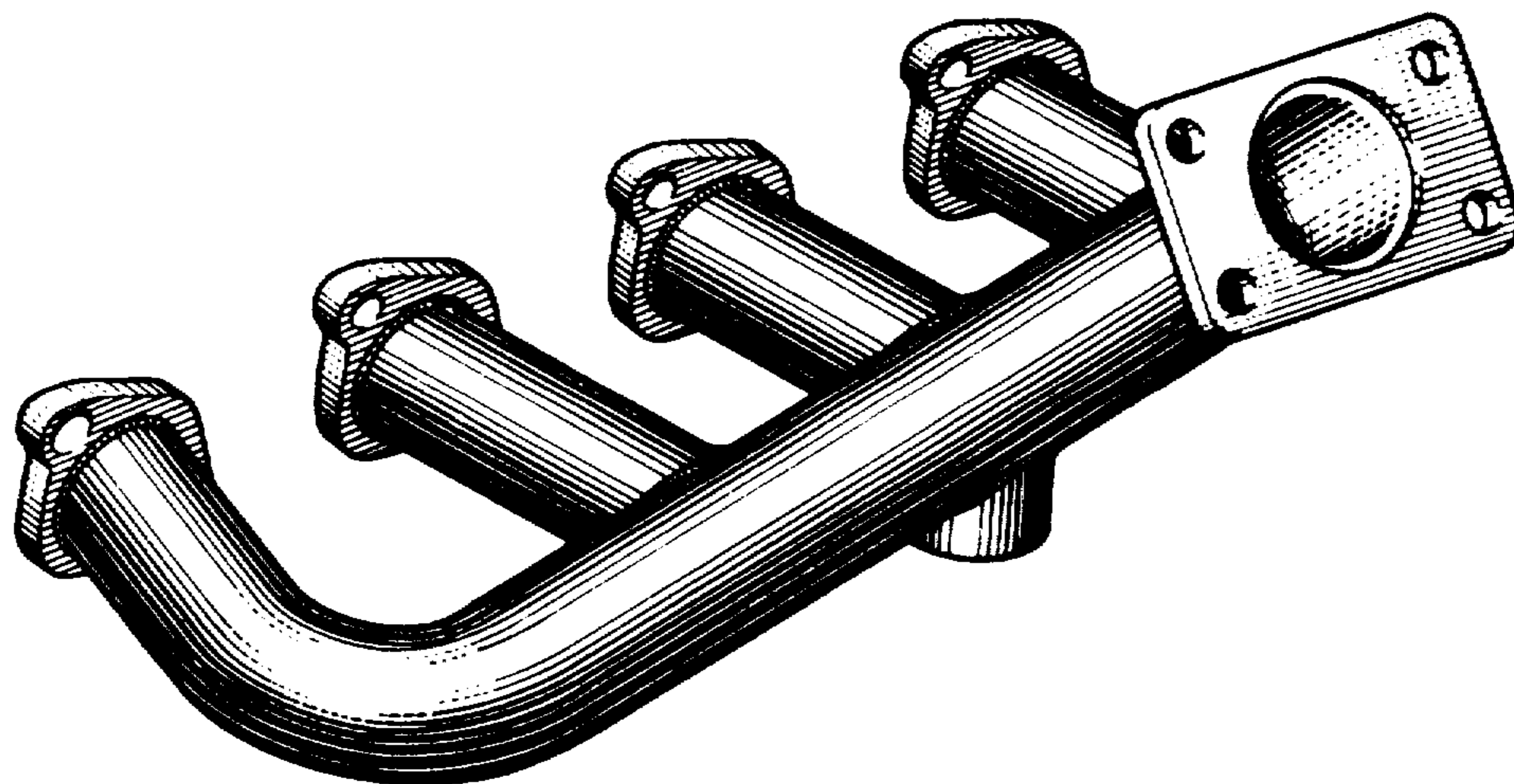

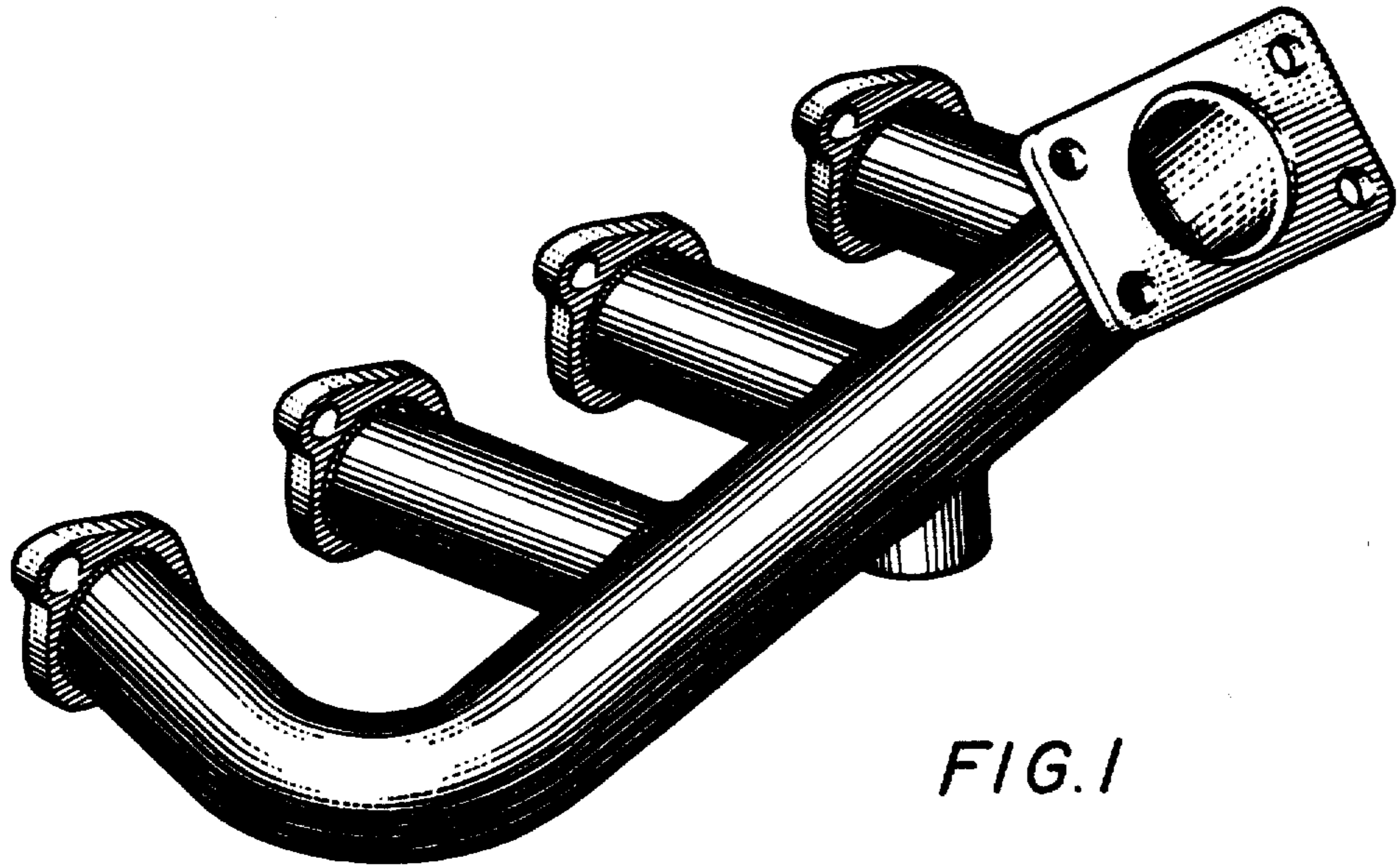

FIG. 1

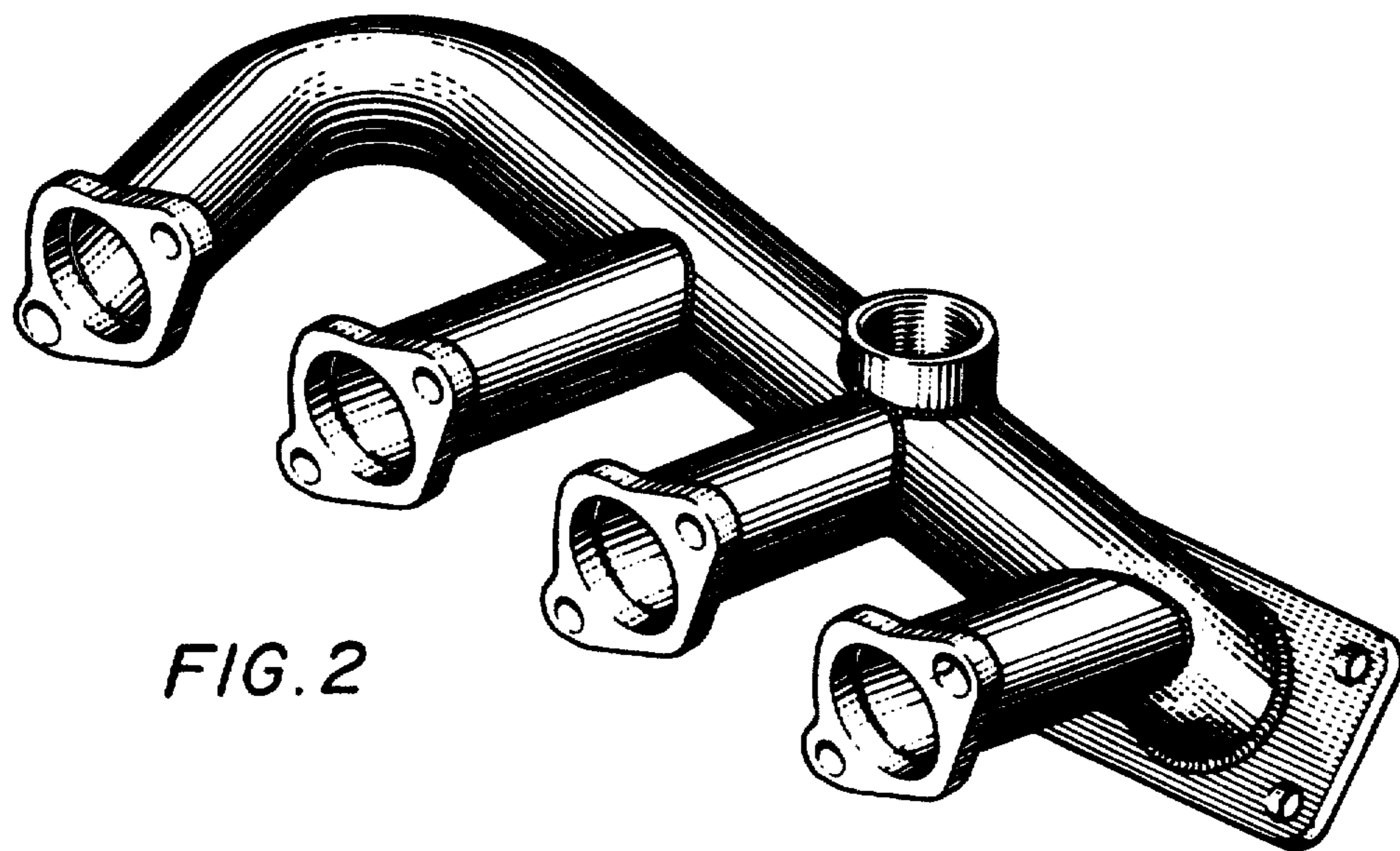

FIG. 2

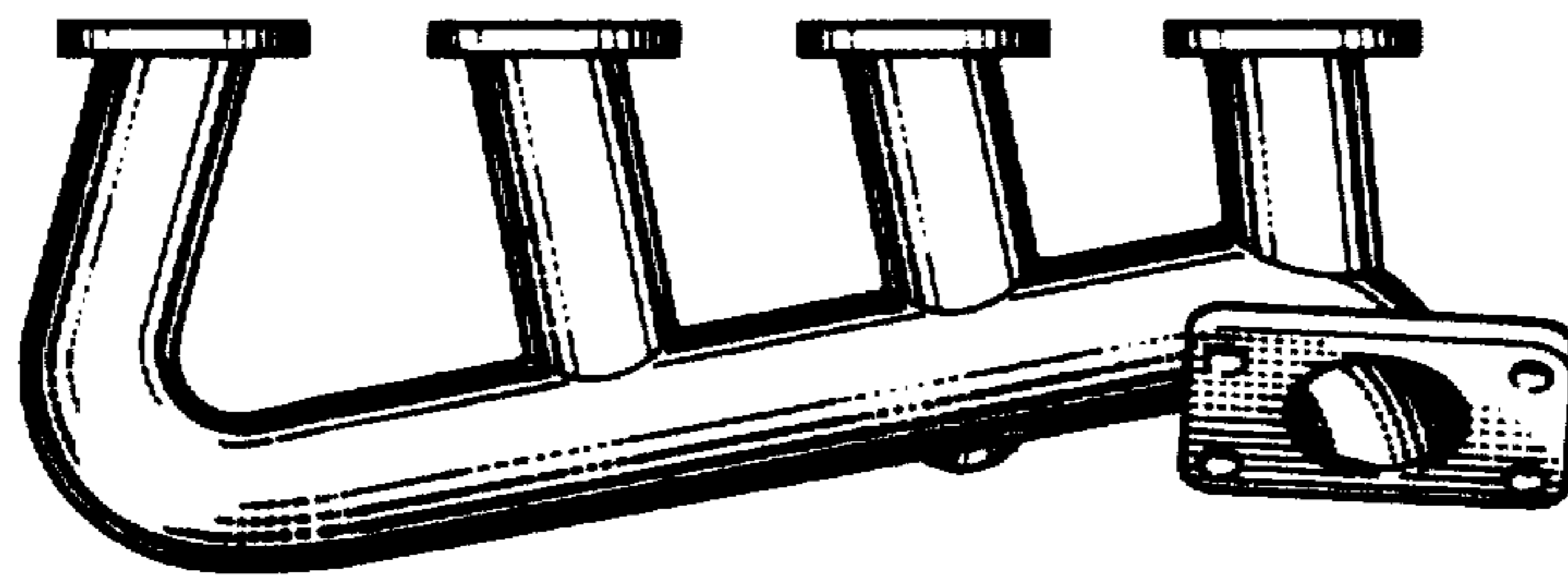

FIG. 3

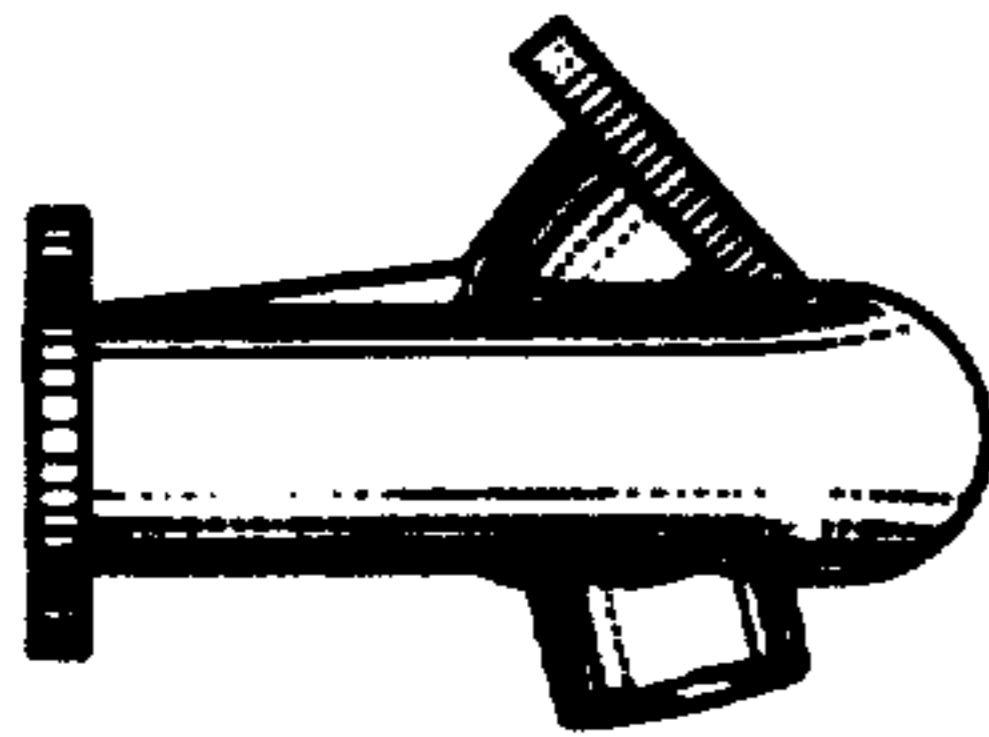

FIG. 7

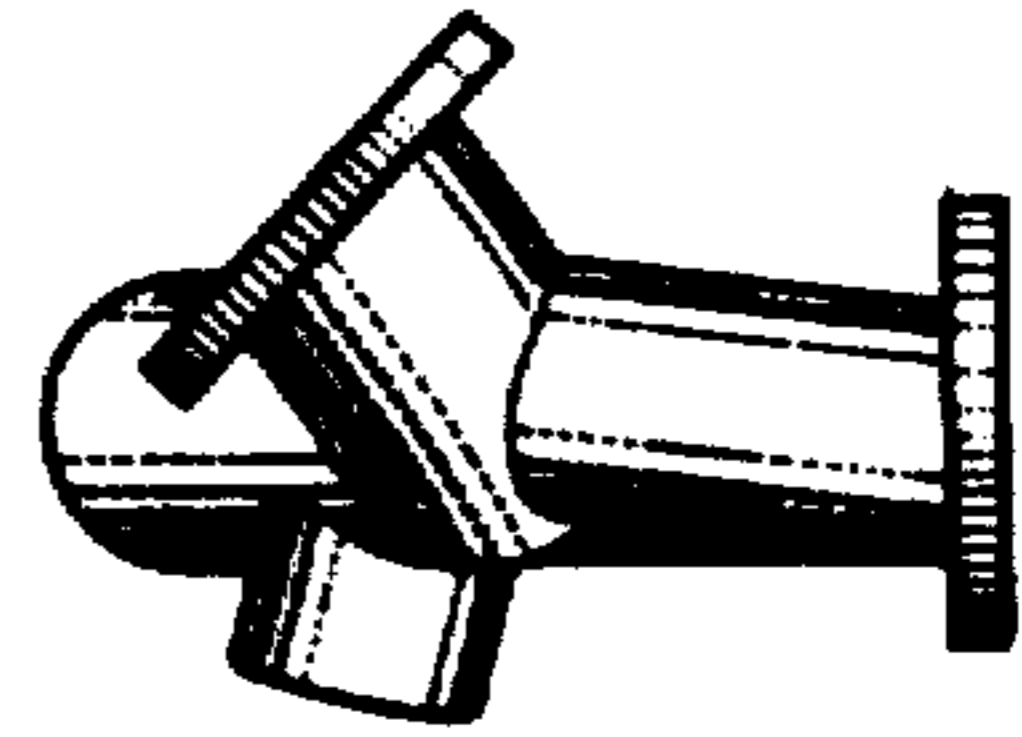

FIG. 8

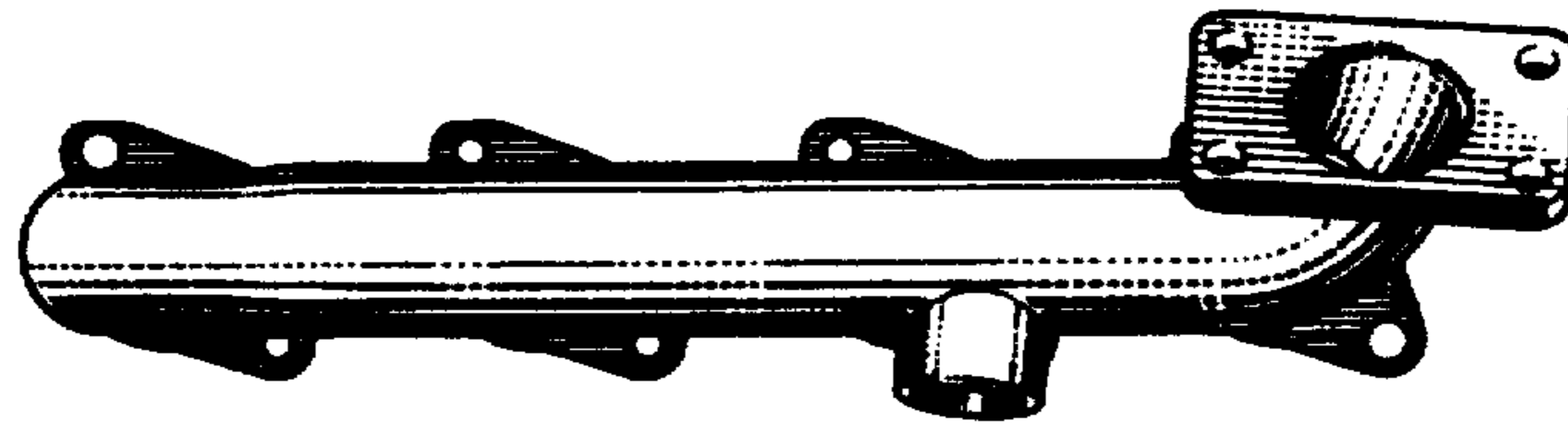

FIG. 4

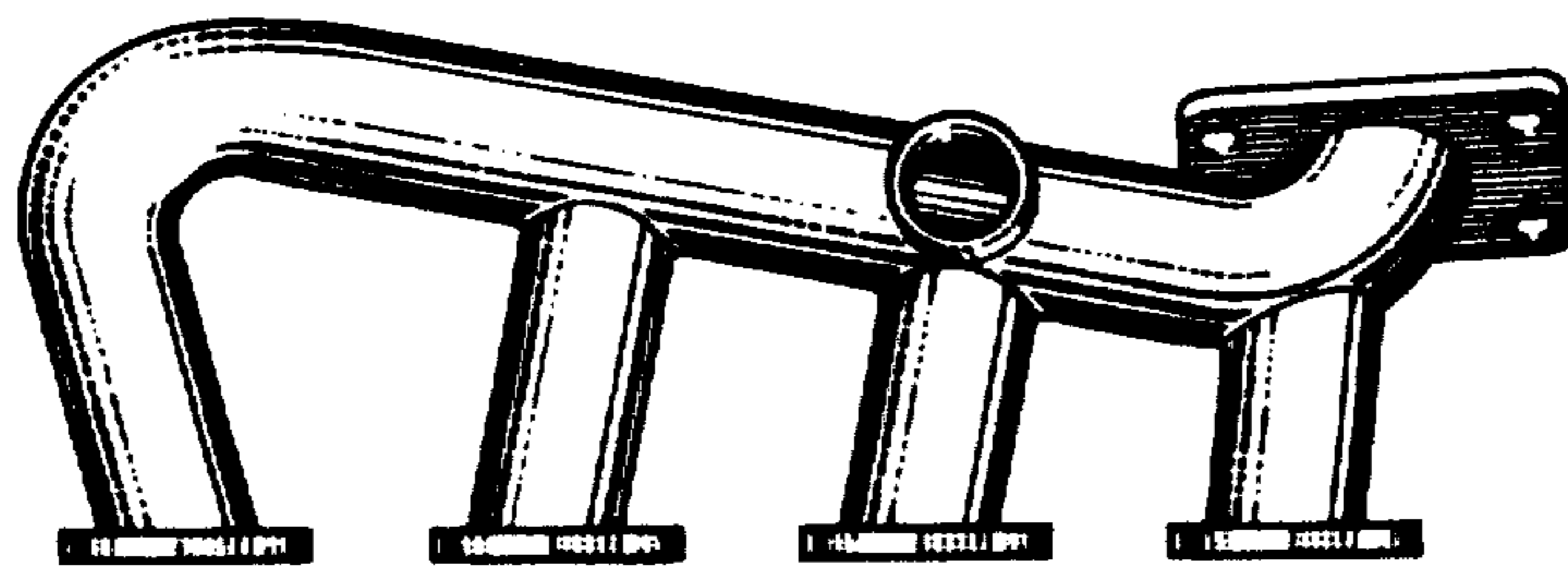

FIG. 5

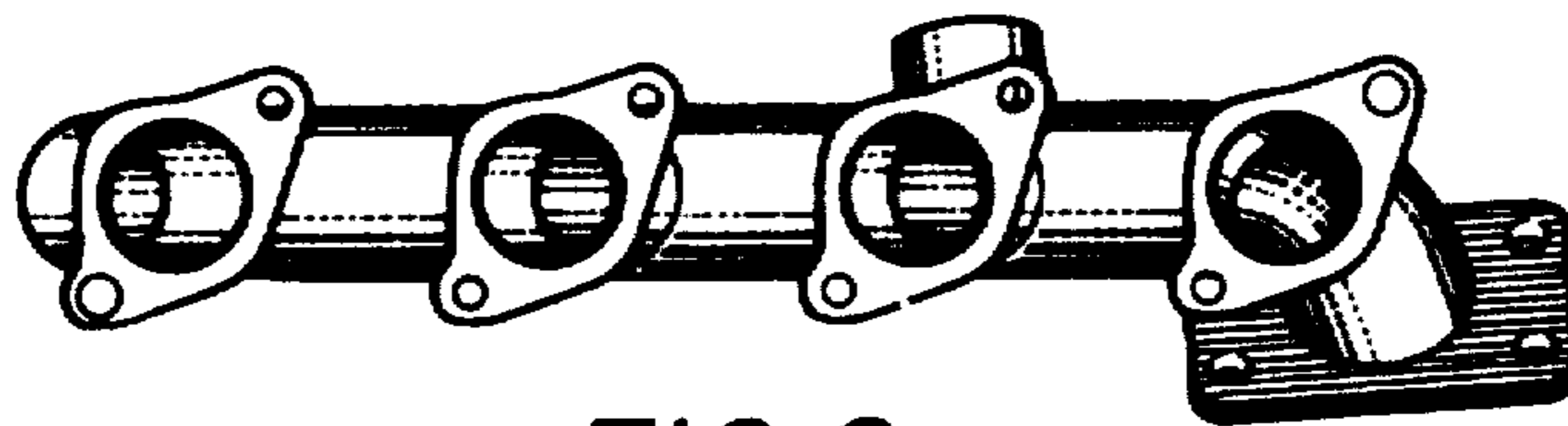

FIG. 6