

[54] AIRCRAFT

[75] Inventor: Gordon Rosenthal, Jericho, N.Y.

[73] Assignee: Fairchild Industries, Inc.,
Germantown, Md.

[**] Term: 14 Years

[21] Appl. No.: 80,801

[22] Filed: Oct. 1, 1979

[51] Int. Cl. D12-07

[52] U.S. Cl. D12/332; D12/338;
D12/340; D12/343

[58] Field of Search D12/319, 331, 332, 338,
D12/340, 343; 244/45 A, 45 R, 15, 91

[56] References Cited

U.S. PATENT DOCUMENTS

- D. 177,547 4/1956 Wen D12/332
- D. 193,161 7/1962 LeVeille D12/332

- D. 213,735 4/1969 Rollis D12/332
- D. 220,982 6/1971 Webb D12/334
- D. 232,710 9/1974 Moore D12/340
- D. 256,347 8/1980 McComas D12/333
- D. 257,338 10/1980 McComas D12/332

Primary Examiner—T. Tung
Attorney, Agent, or Firm—Michael W. York

[57] CLAIM

The ornamental design for an aircraft, substantially as shown and described.

DESCRIPTION

FIG. 1 is a top plan view of an aircraft showing my new design;

FIG. 2 is an elevational view of one side of said aircraft, the elevational view of the other side being substantially a mirror image thereof;

FIG. 3 is a bottom plan view of said aircraft;

FIG. 4 is an elevational view of the front of said aircraft;

FIG. 5 is an elevational view of the rear of said aircraft.

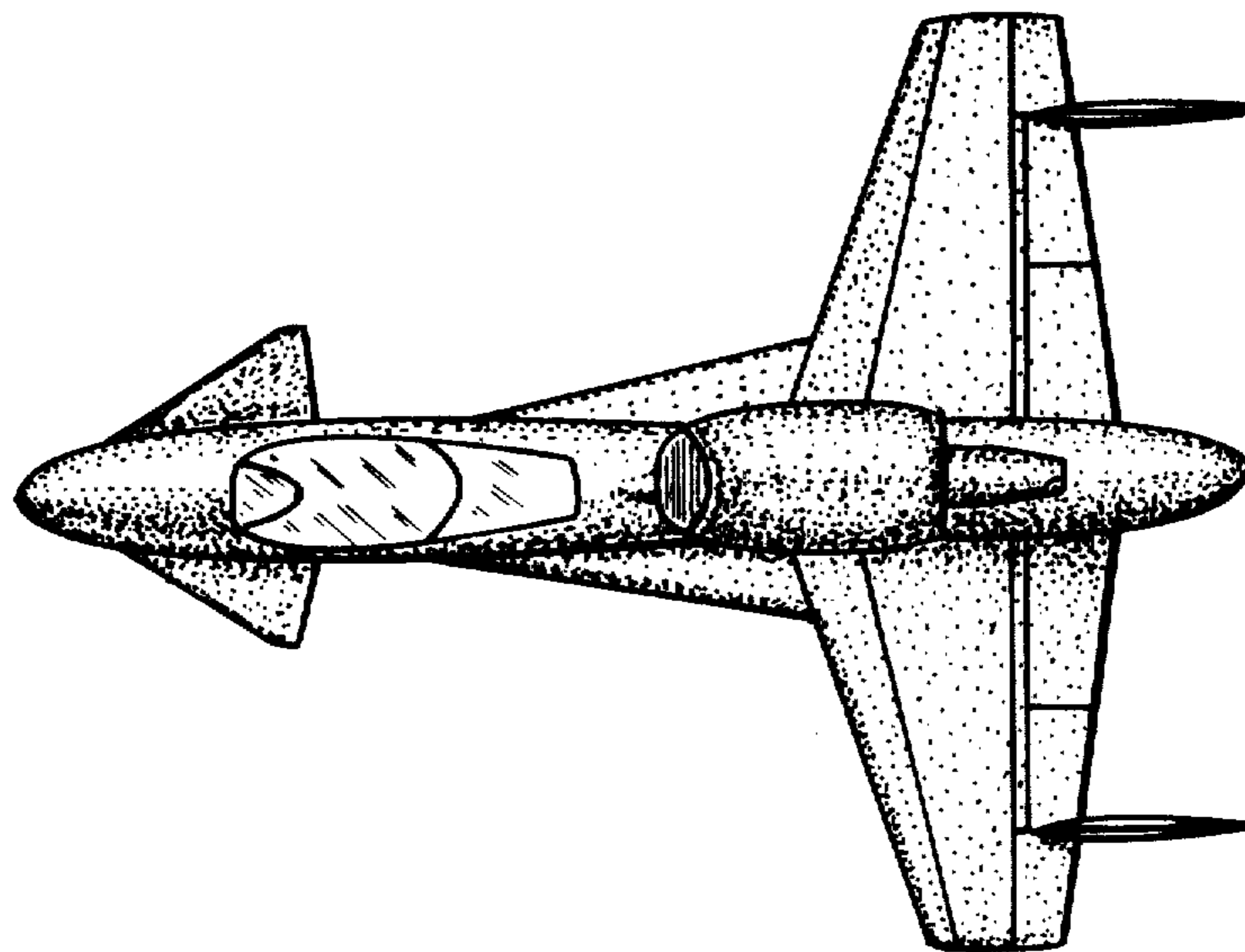

Fig. 1

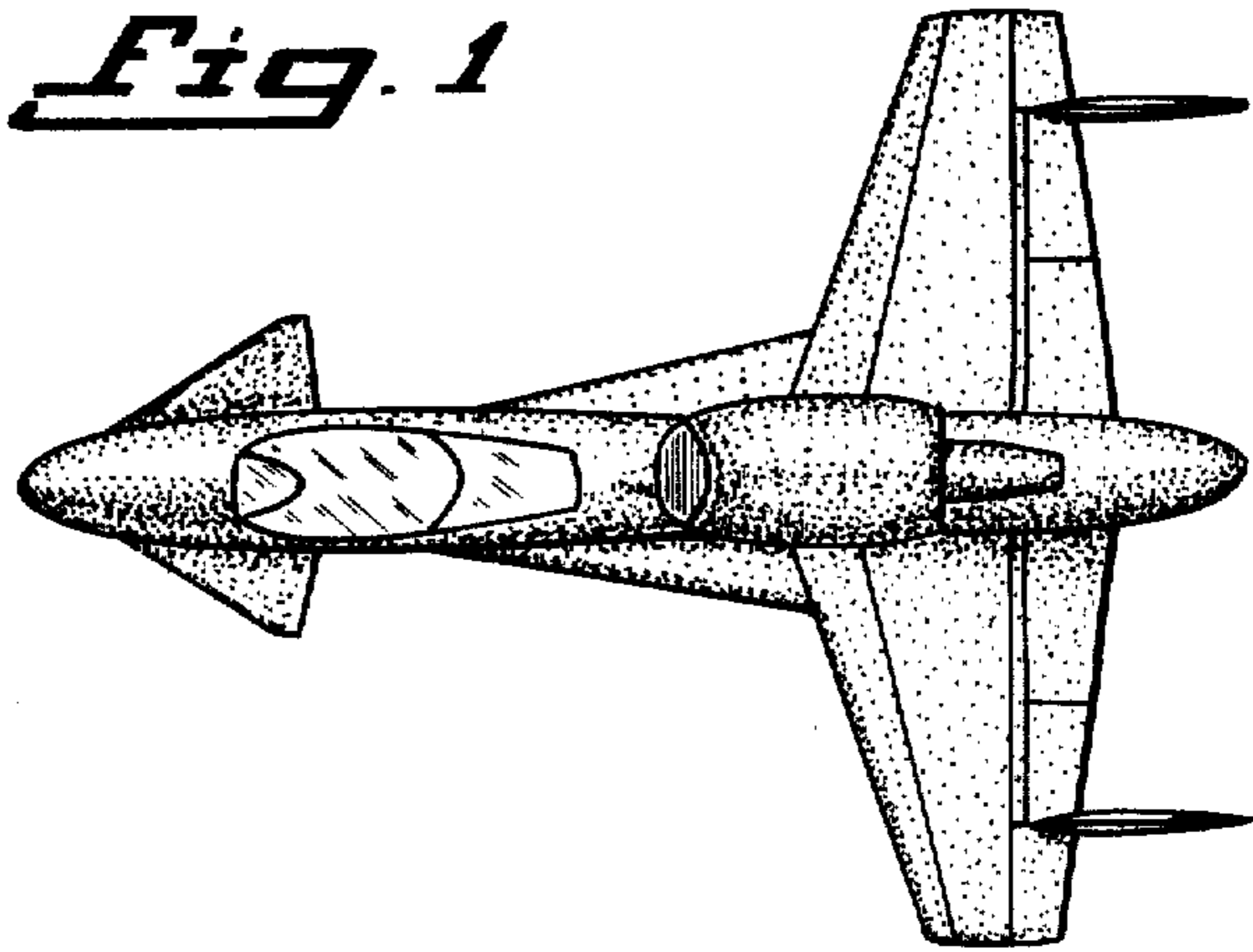

Fig. 2

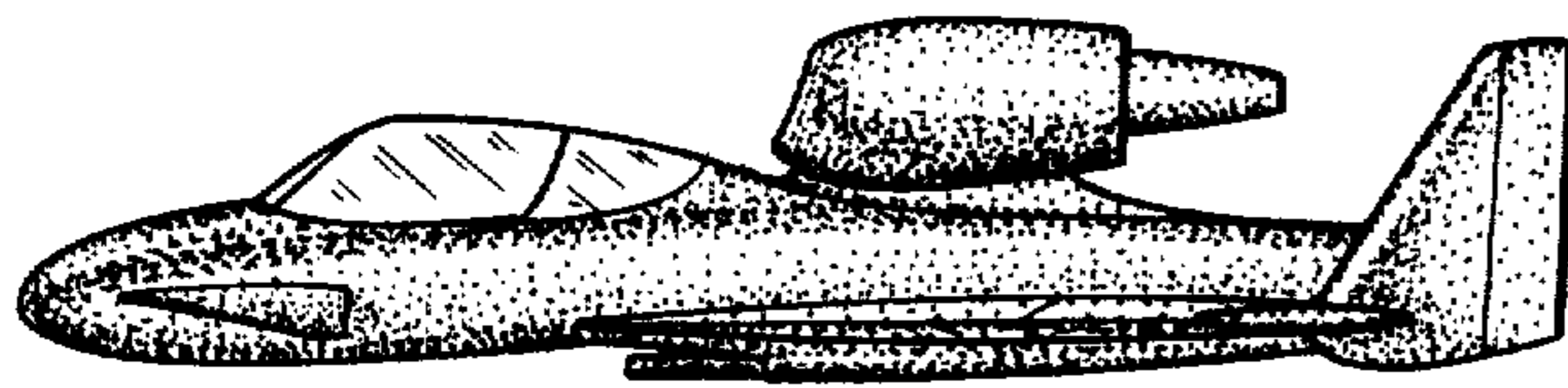

Fig. 3

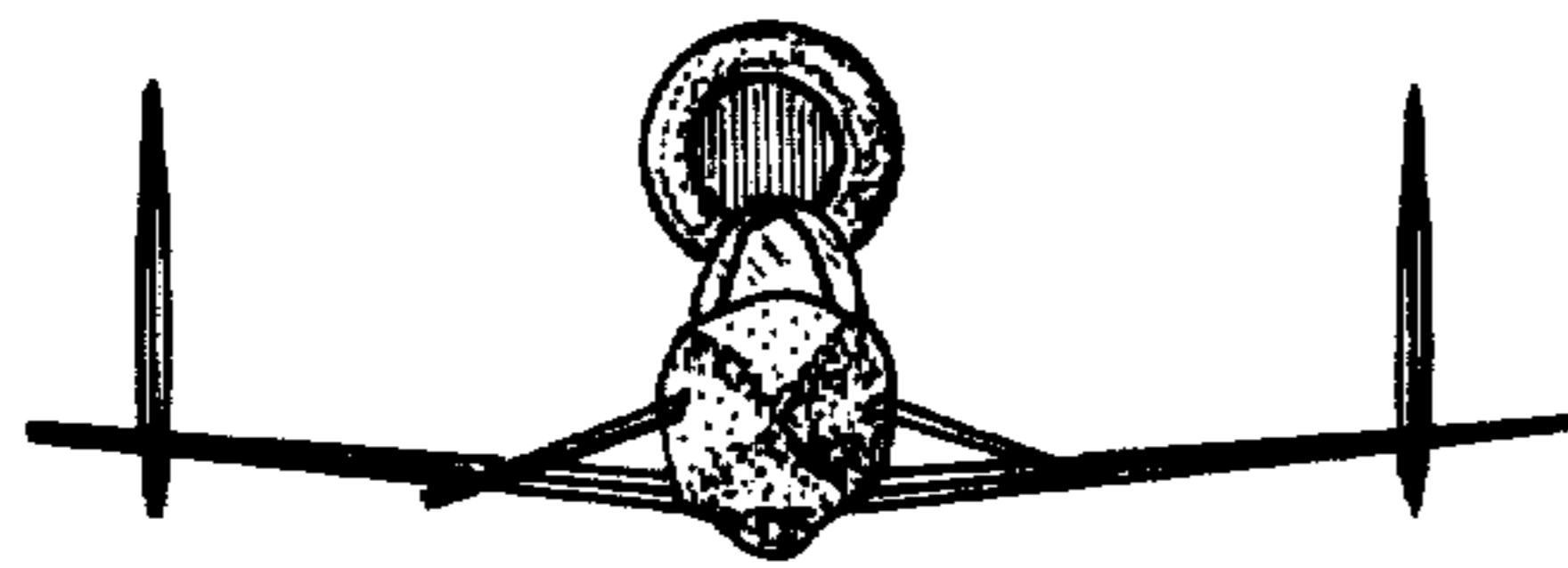
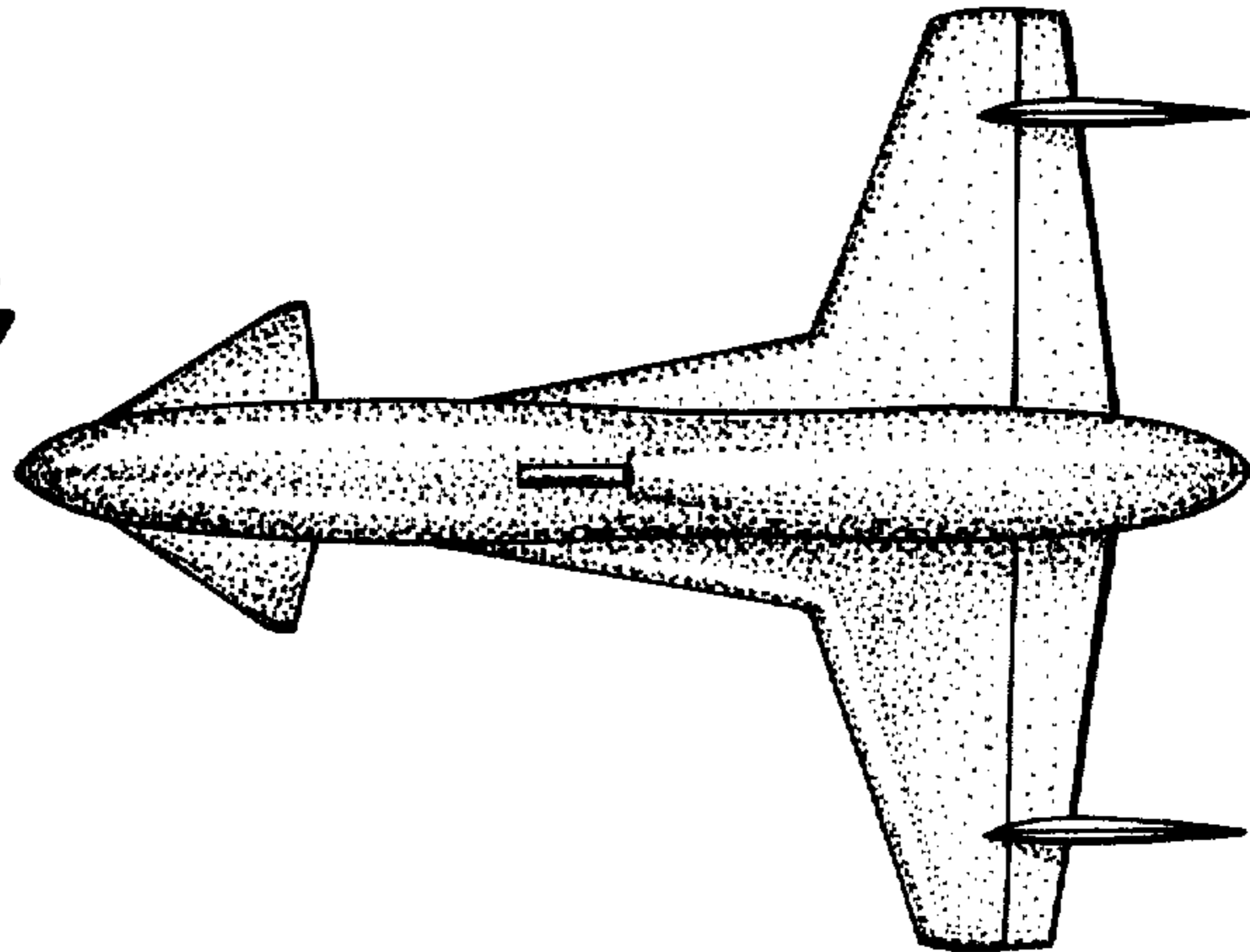

Fig. 4

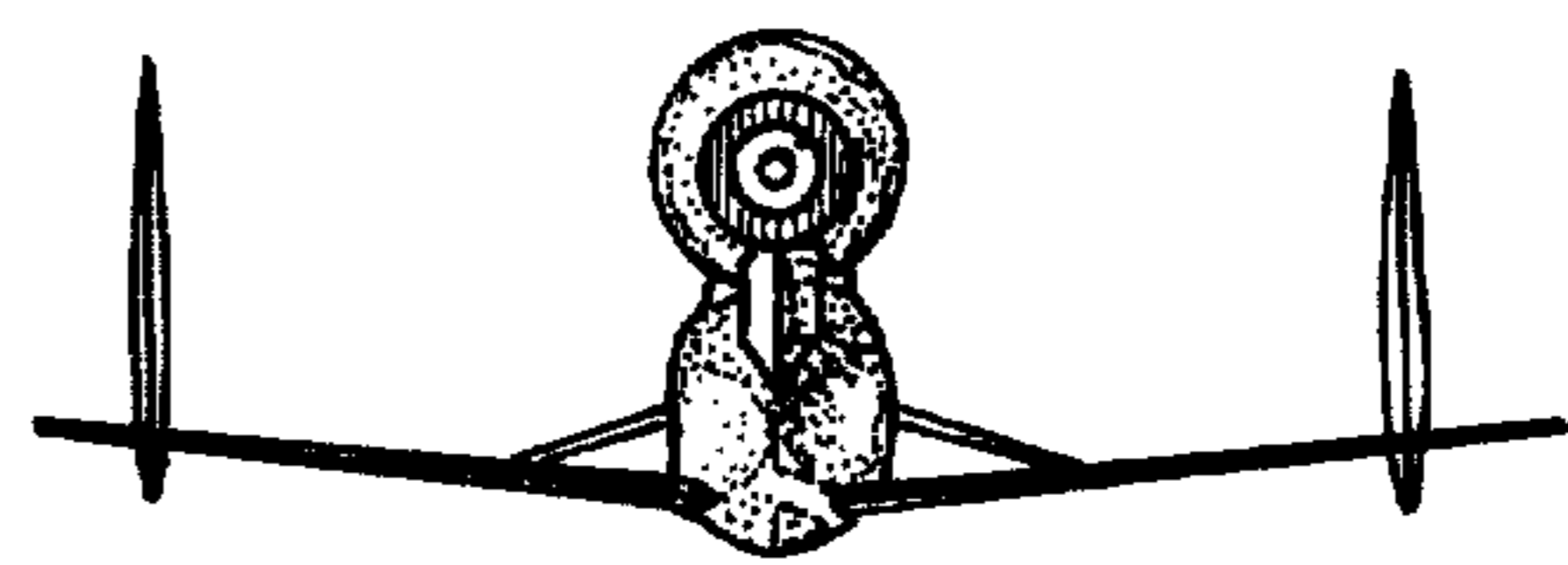

Fig. 5