

[54] MOTOR BOAT

[75] Inventors: Keisuke Tomonaga, Akashi; Hiroshi Nishida; Takeshi Miyazaki, both of Miki, all of Japan

[73] Assignee: Kawasaki Jukogyo Kabushiki Kaisha, Hyogo, Japan

[**] Term: 14 Years

[21] Appl. No.: 140,683

[22] Filed: Apr. 16, 1980

[30] Foreign Application Priority Data

Oct. 18, 1979 [JP] Japan 54-43792

[51] Int. Cl. D12-06

[52] U.S. Cl. D12/307

[58] Field of Search D12/307; 114/270

[56] References Cited

U.S. PATENT DOCUMENTS

- D. 226,036 1/1973 Jacobson D21/228
- D. 233,140 10/1974 Tanaka et al. D21/228

D. 241,328 9/1976 Naito et al. D12/307

Primary Examiner—James M. Gandy
Attorney, Agent, or Firm—Kerkam, Stowell, Kondracki & Clarke

[57] CLAIM

The ornamental design for a motor boat, as shown and described.

DESCRIPTION

FIG. 1 is a perspective view of a motor boat showing our new design;
 FIG. 2 is a front elevational view thereof;
 FIG. 3 is a rear elevational view thereof;
 FIG. 4 is a right side elevational view thereof;
 FIG. 5 is a top plan view thereof;
 FIG. 6 is a bottom plan view thereof;
 FIGS. 7 and 8 are front and right side elevational views thereof, respectively with the floats and the handle in retracted positions;
 FIG. 9 is a sectional view thereof taken along the line 9—9 in FIG. 4; and,
 FIG. 10 is a sectional view thereof taken along the line 10—10 in FIG. 5.

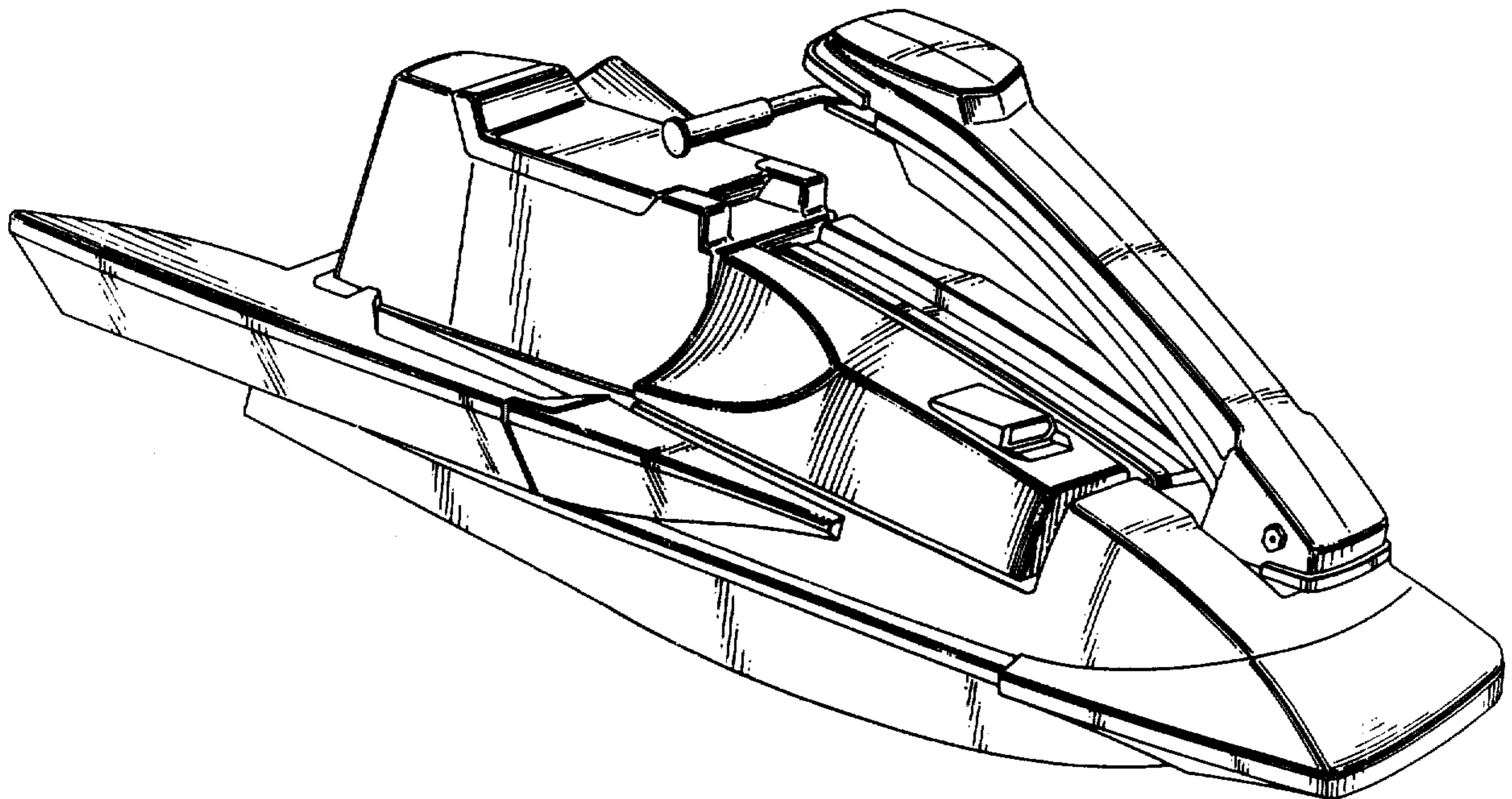

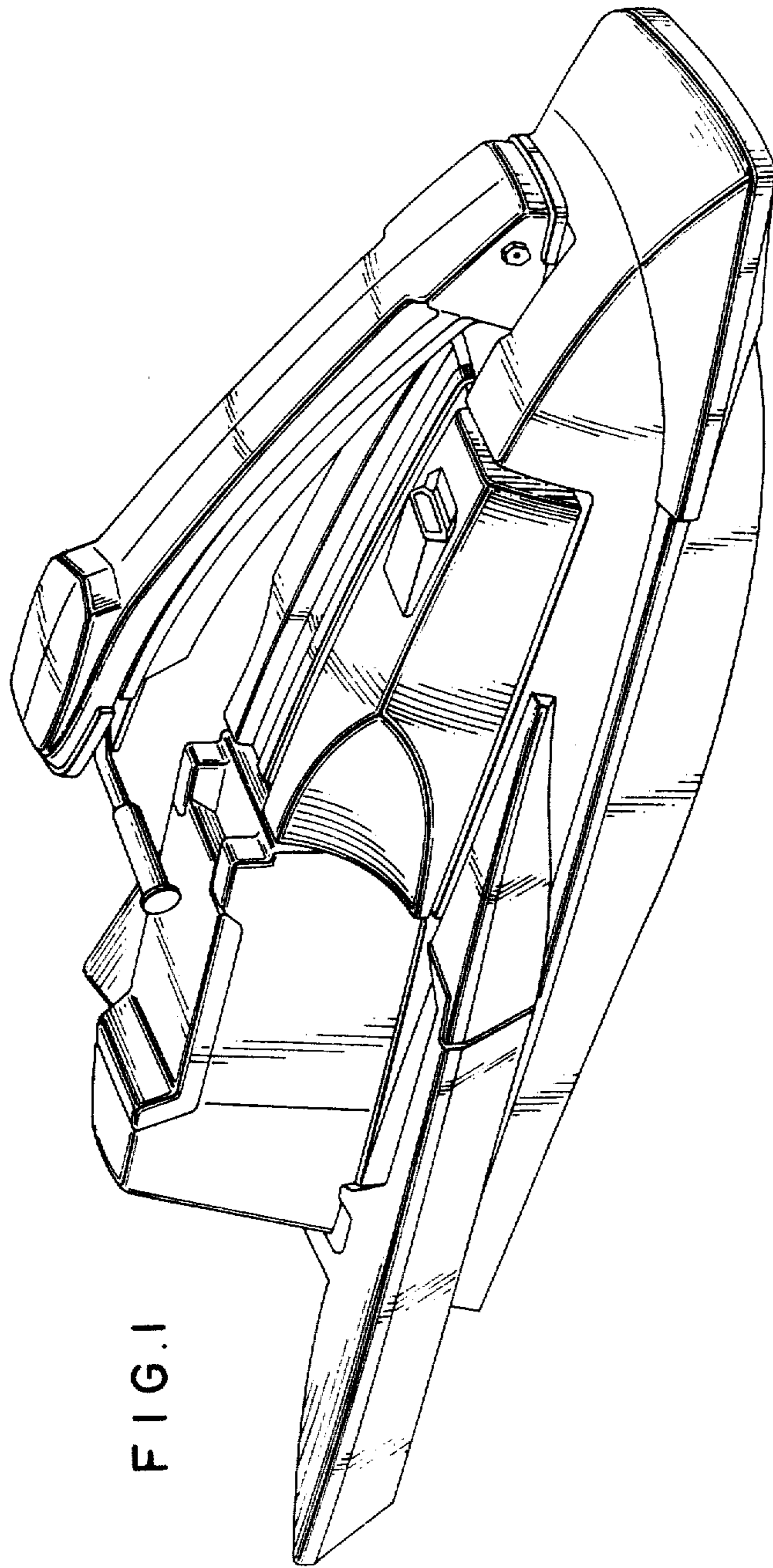
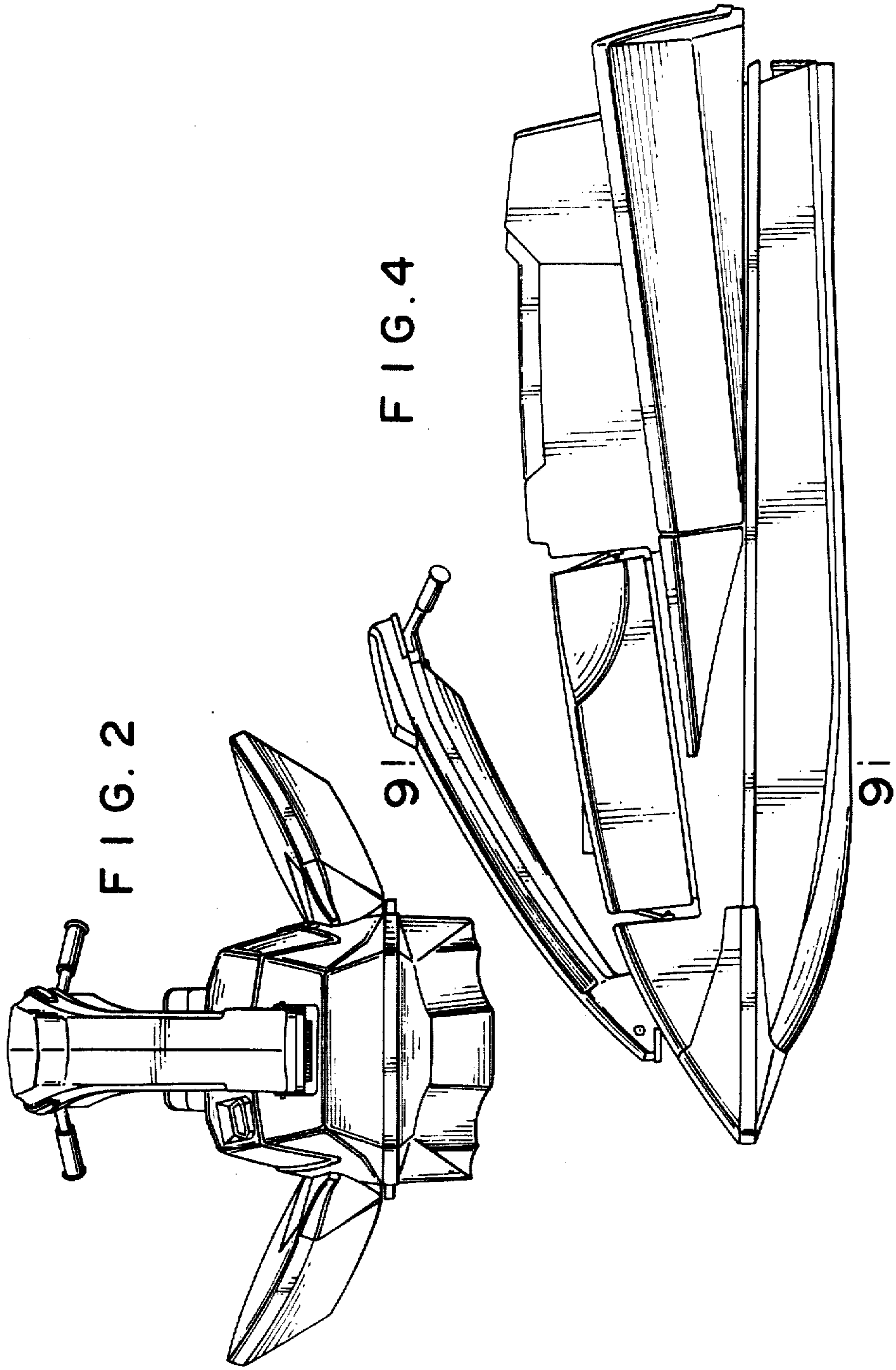

FIG. 1



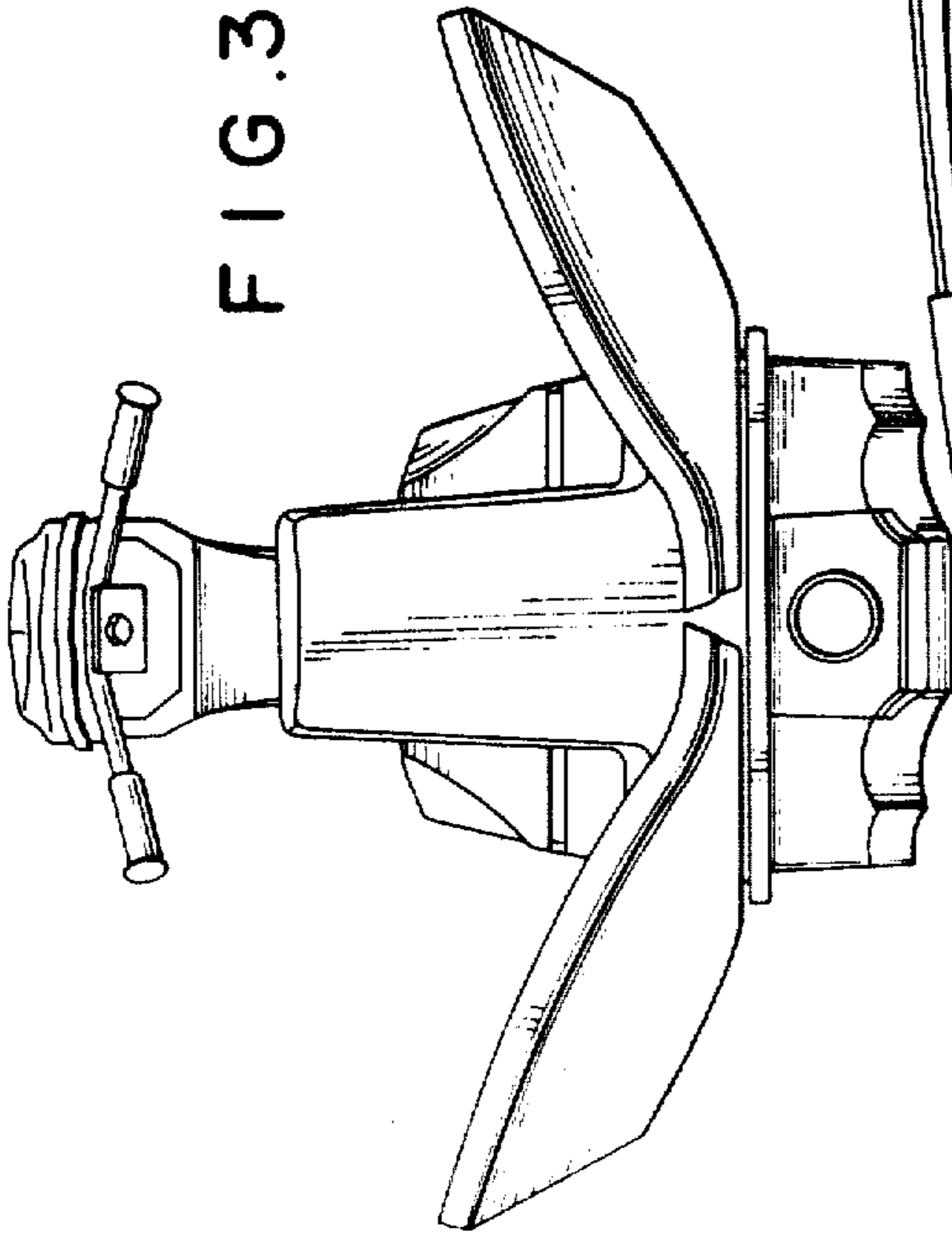
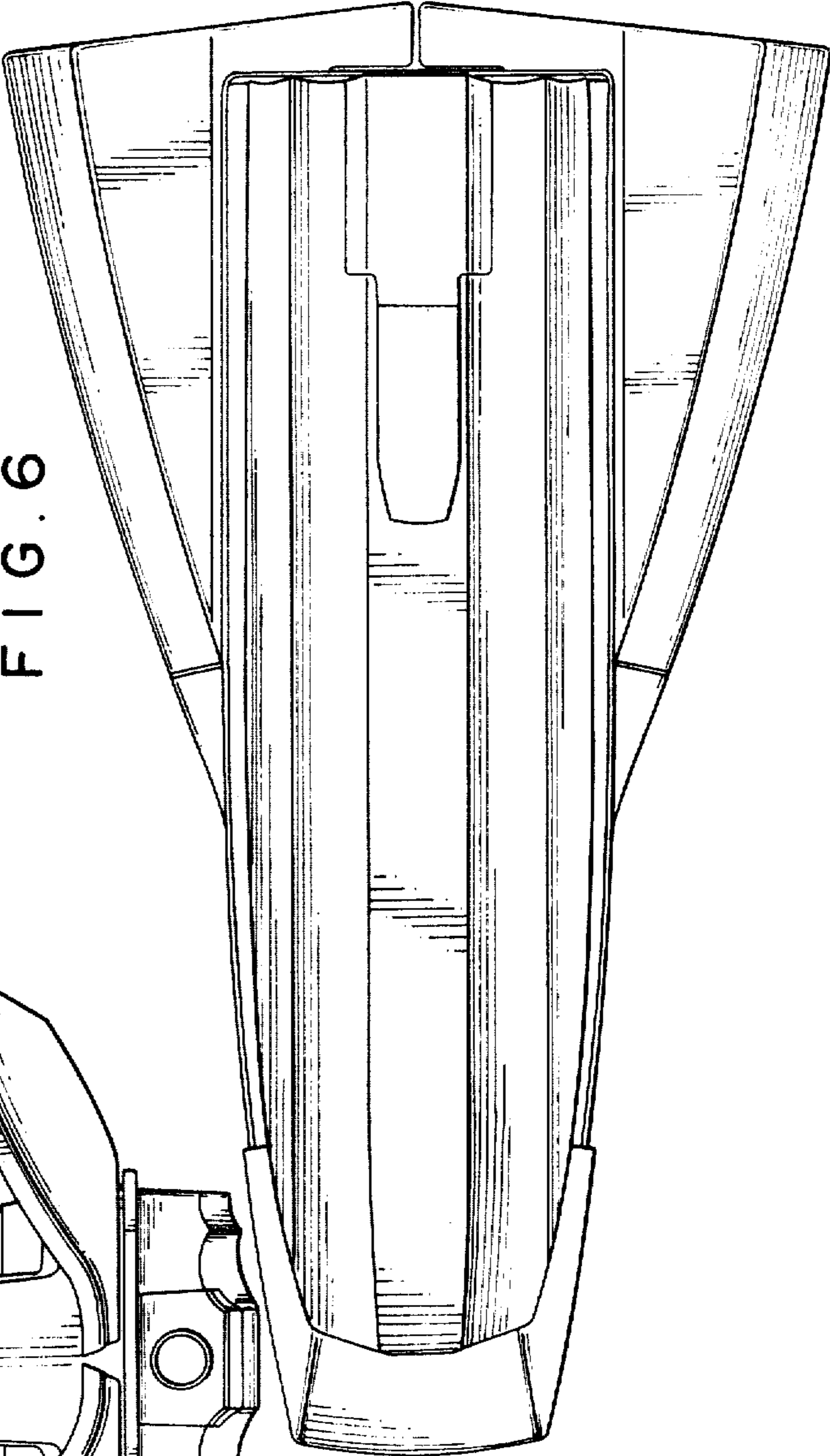

FIG. 6



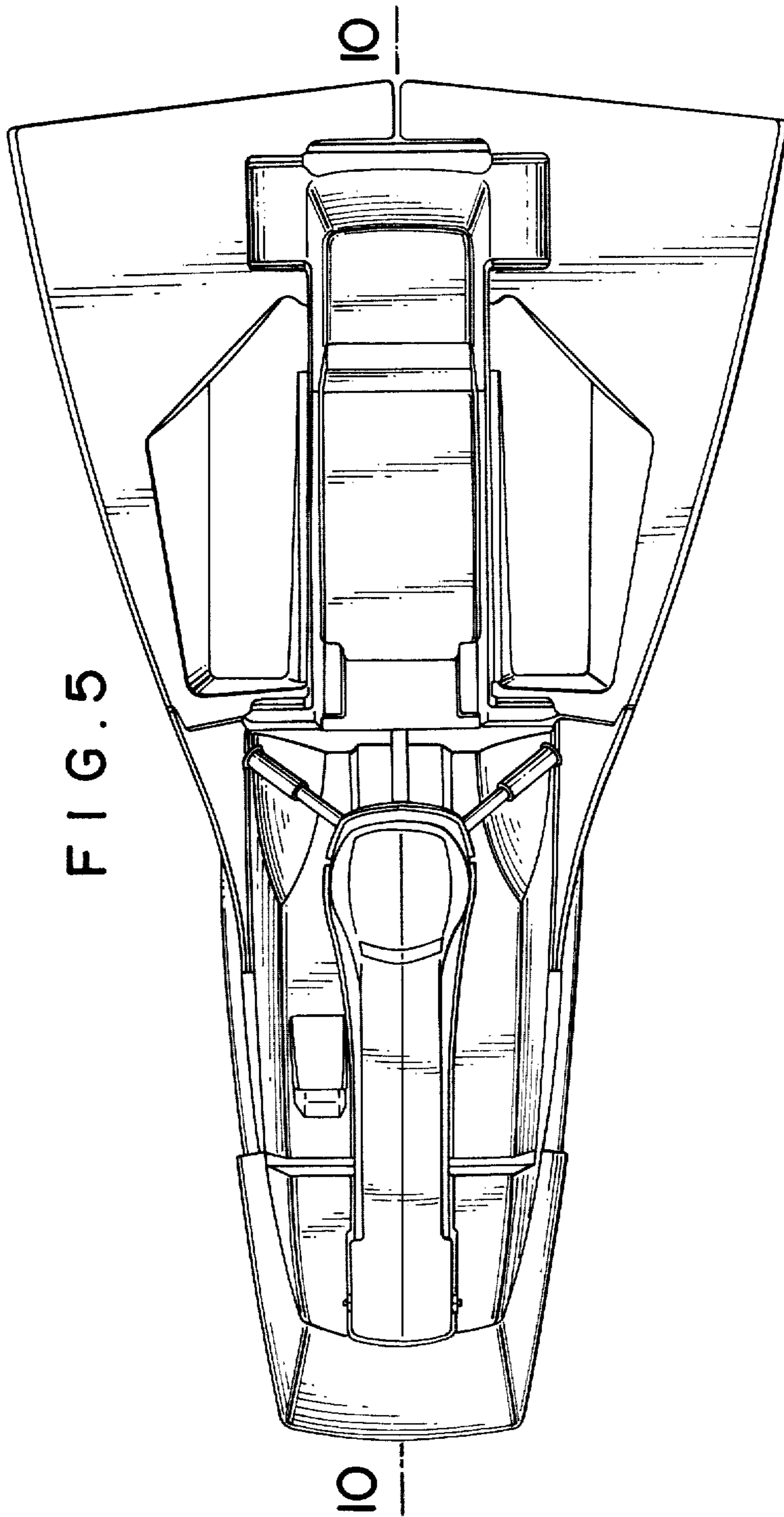

FIG. 7

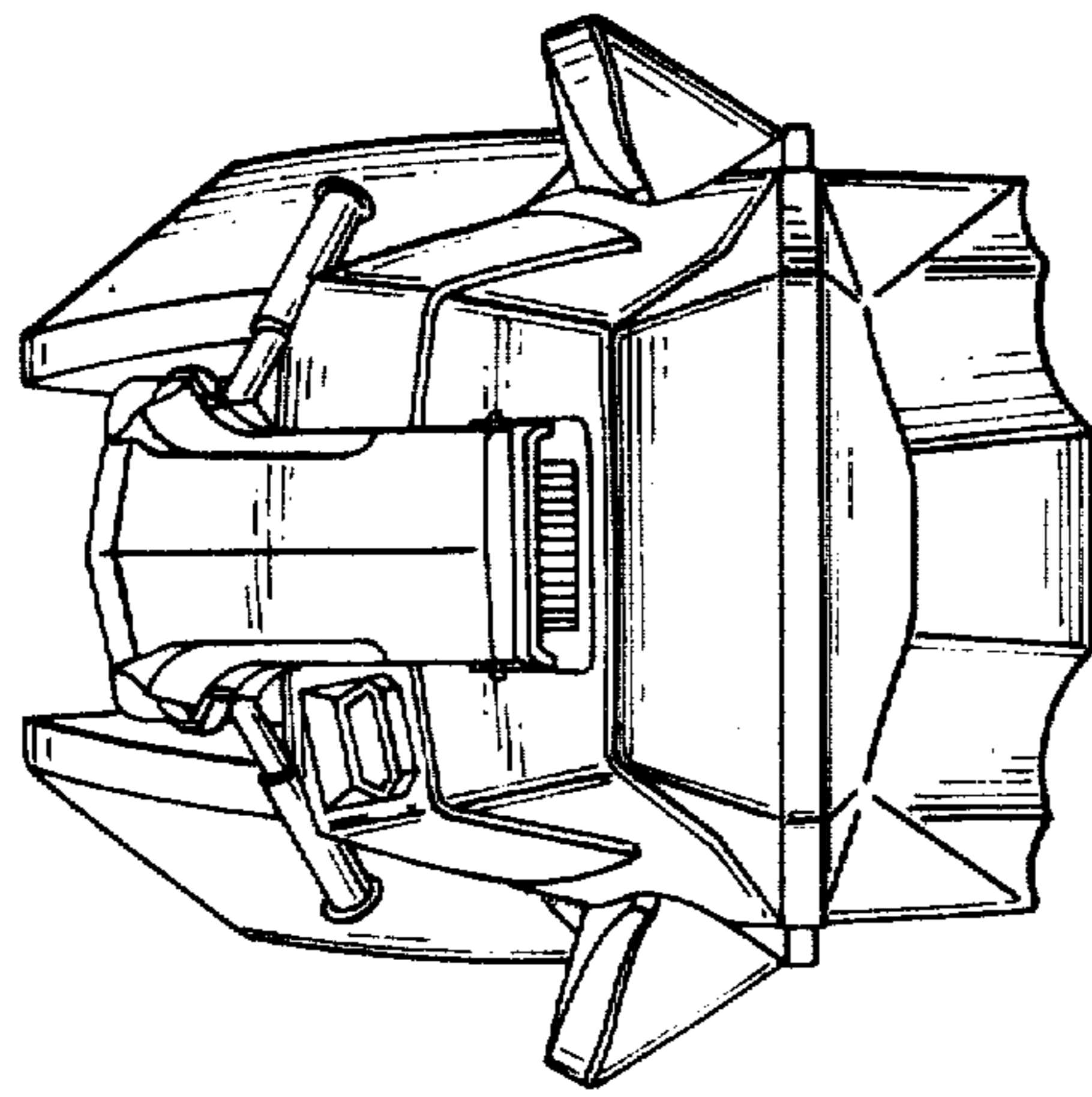
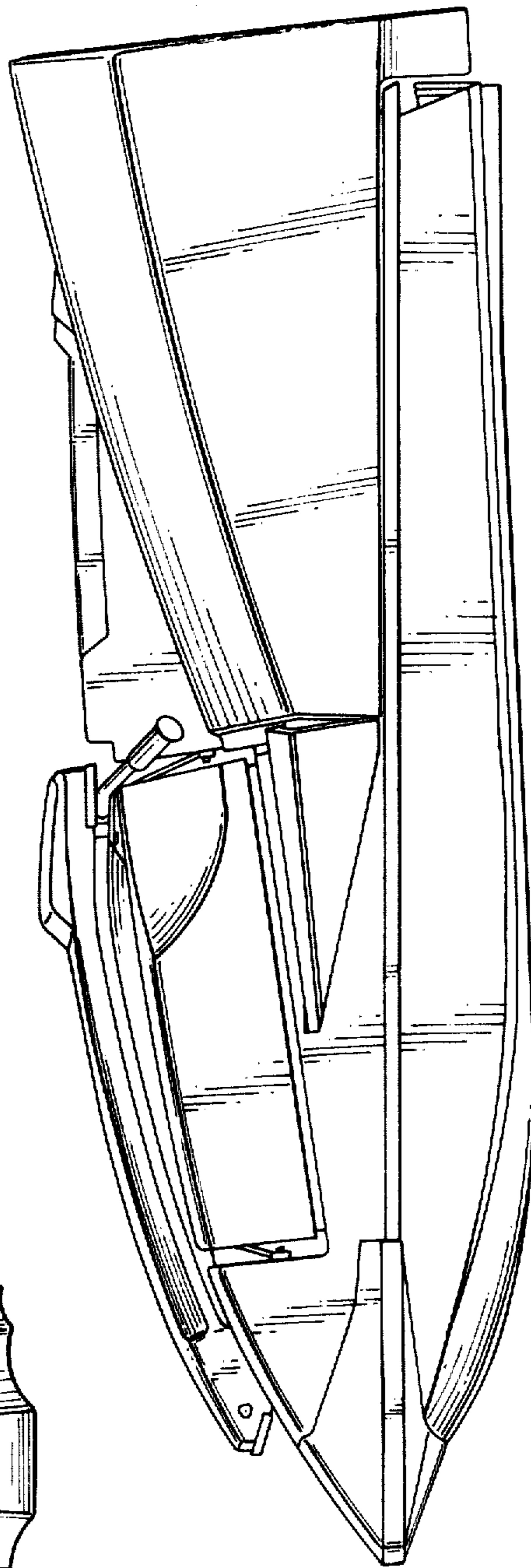

FIG. 8



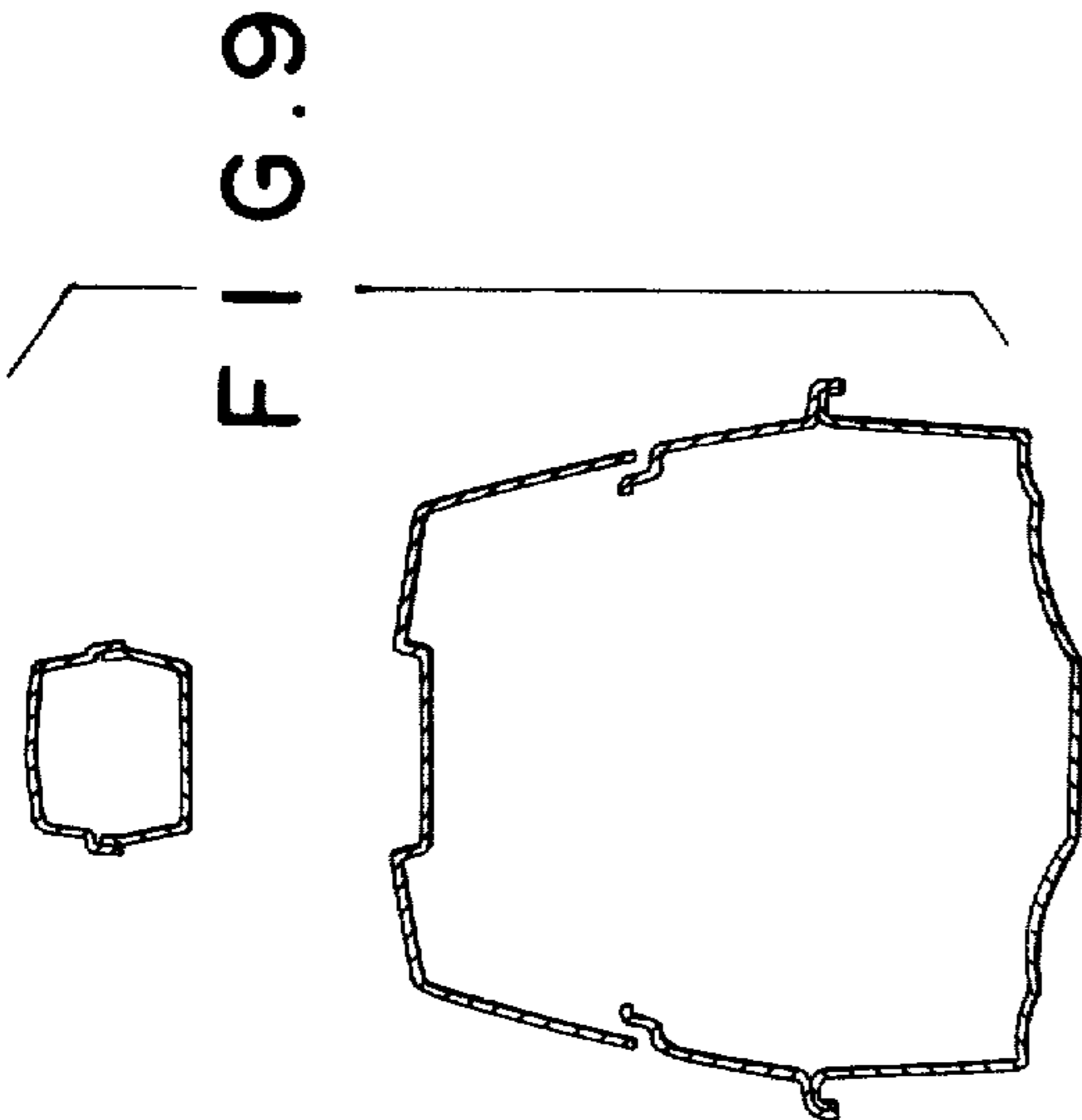

FIG. 10

