

[54] **SKI AND LUGGAGE CARRIER FOR VEHICLES**

[76] Inventor: **Jan-Erik Brorsson**, Häggatan 10, S-510 54 Brämhult, Sweden

[\*\*] Term: **14 Years**

[21] Appl. No.: **147,070**

[22] Filed: **May 6, 1980**

[30] **Foreign Application Priority Data**

Nov. 13, 1979 [SE] Sweden ..... 792497

[51] Int. Cl. .... **D12-16**

[52] U.S. Cl. .... **D12/157**

[58] Field of Search ..... **D12/157; 224/328, 329, 224/309**

[56] **References Cited**

**U.S. PATENT DOCUMENTS**

D. 238,113 12/1975 Hart ..... **D12/157**

D. 250,526 12/1978 Breitschwerdt et al. .... **D12/157**

*Primary Examiner*—James M. Gandy

[57] **CLAIM**

The ornamental design for a ski and luggage carrier for vehicles, as shown and described.

**DESCRIPTION**

FIG. 1 is a top, front and right side perspective view of a ski and luggage carrier for vehicles showing my new design, it being understood that the rear is a mirror image of the front shown herein;

FIG. 2 is a top, front and right side perspective view thereof in open condition;

FIG. 3 is a bottom, front and left side perspective view thereof;

FIG. 4 is an enlarged top perspective view of one of the case/lid components thereof, it being understood that the remainder of the carrier has been omitted for clarity of illustration; and

FIG. 5 is a bottom perspective view of FIG. 4.

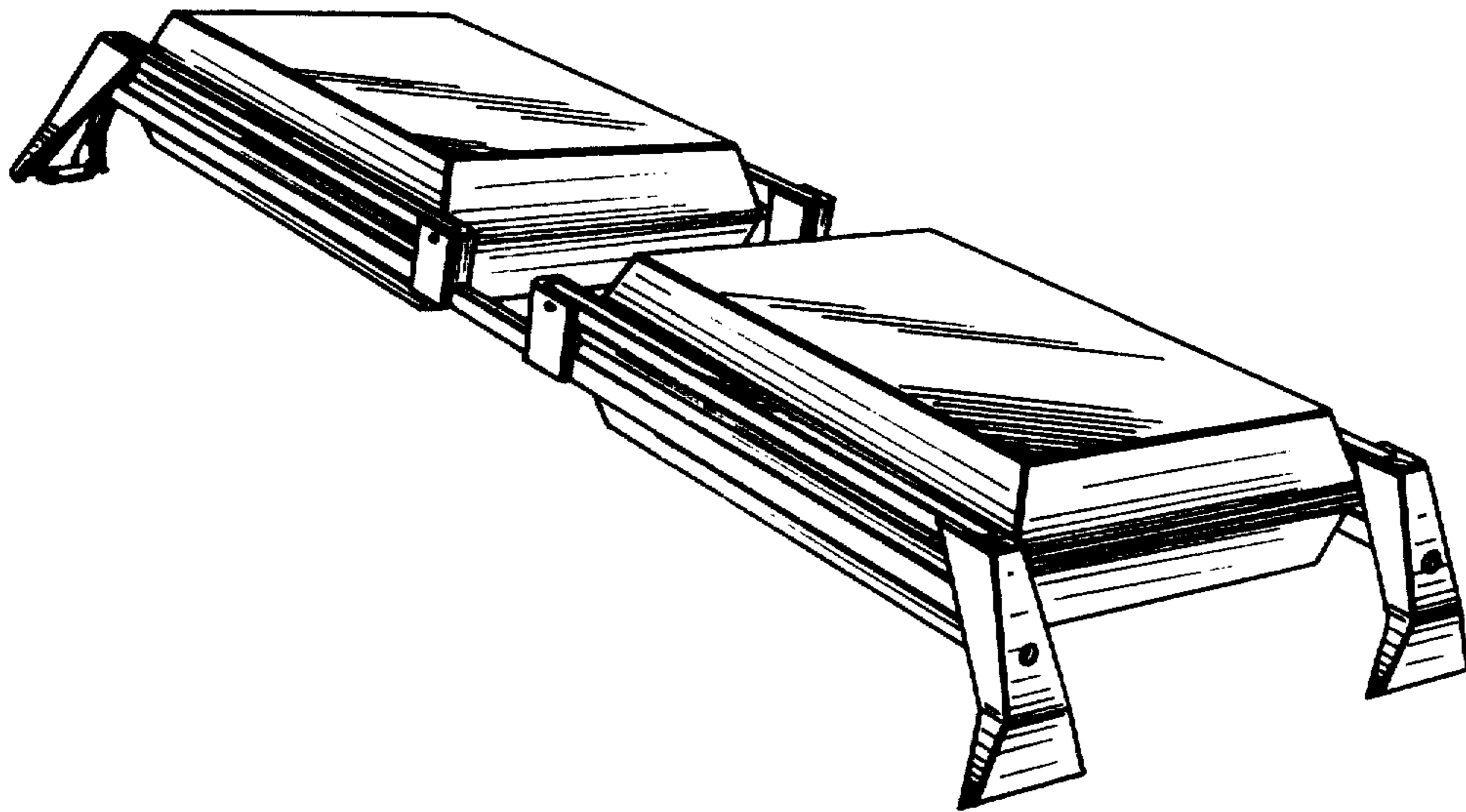

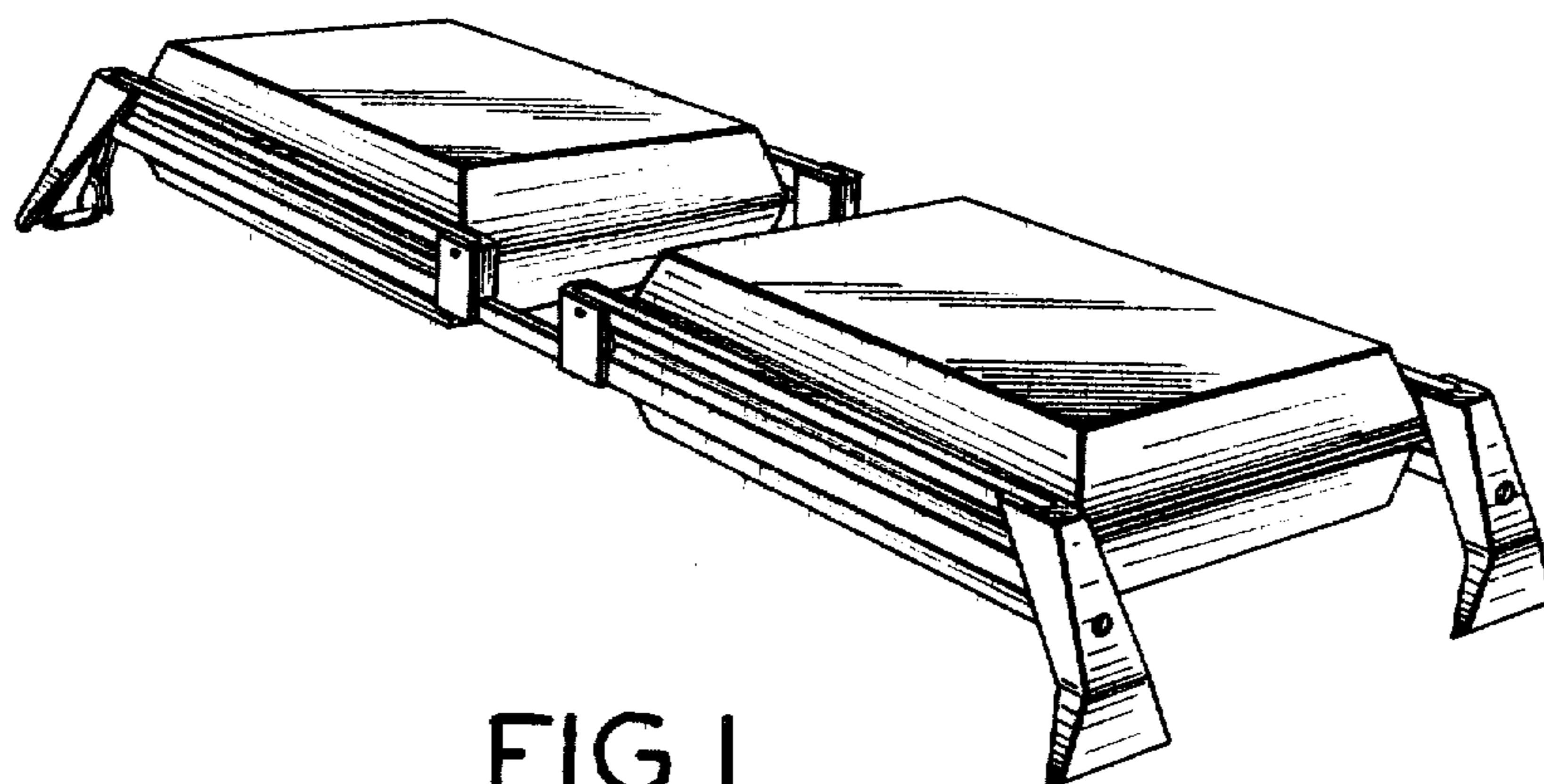

FIG. 1

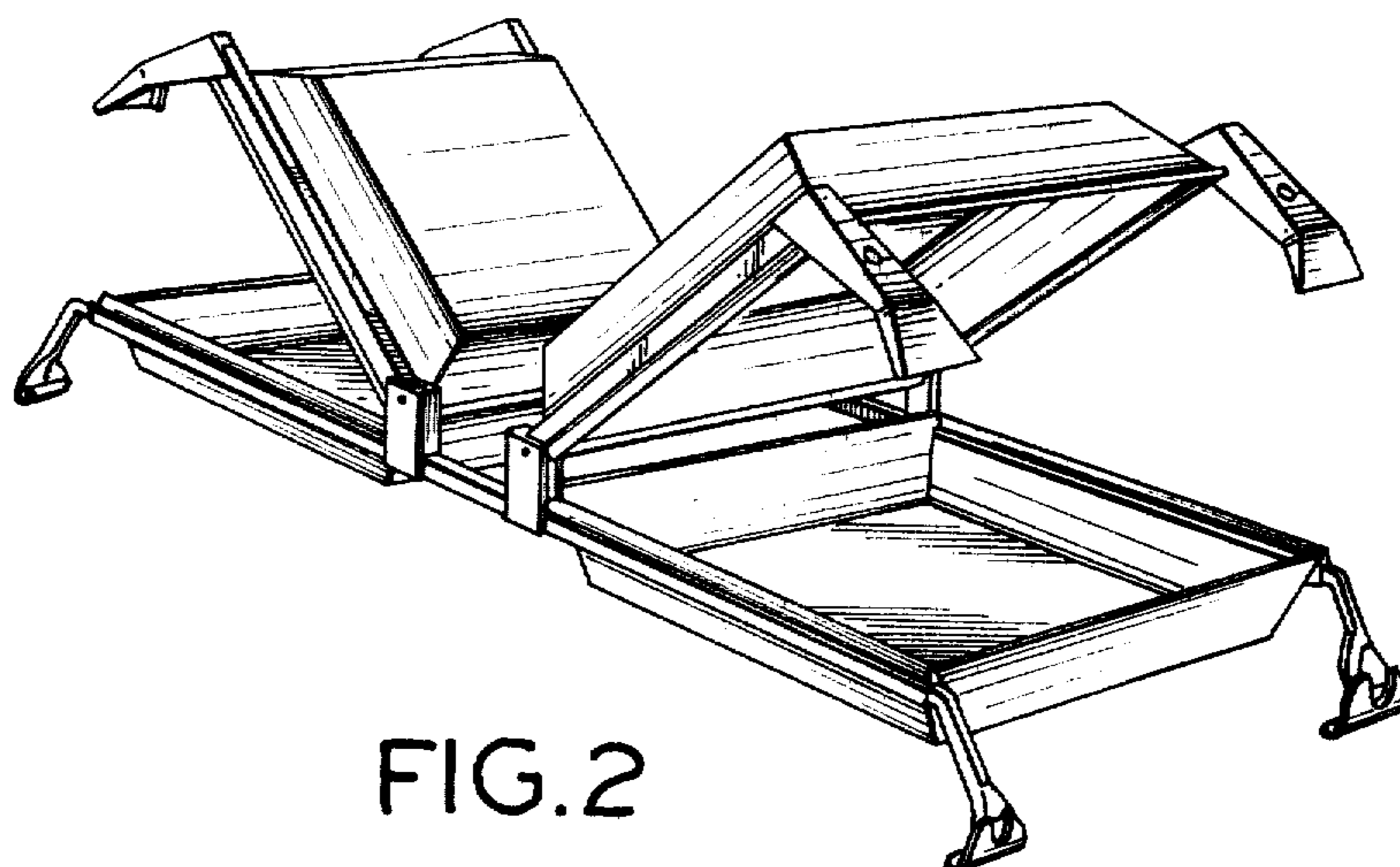

FIG. 2

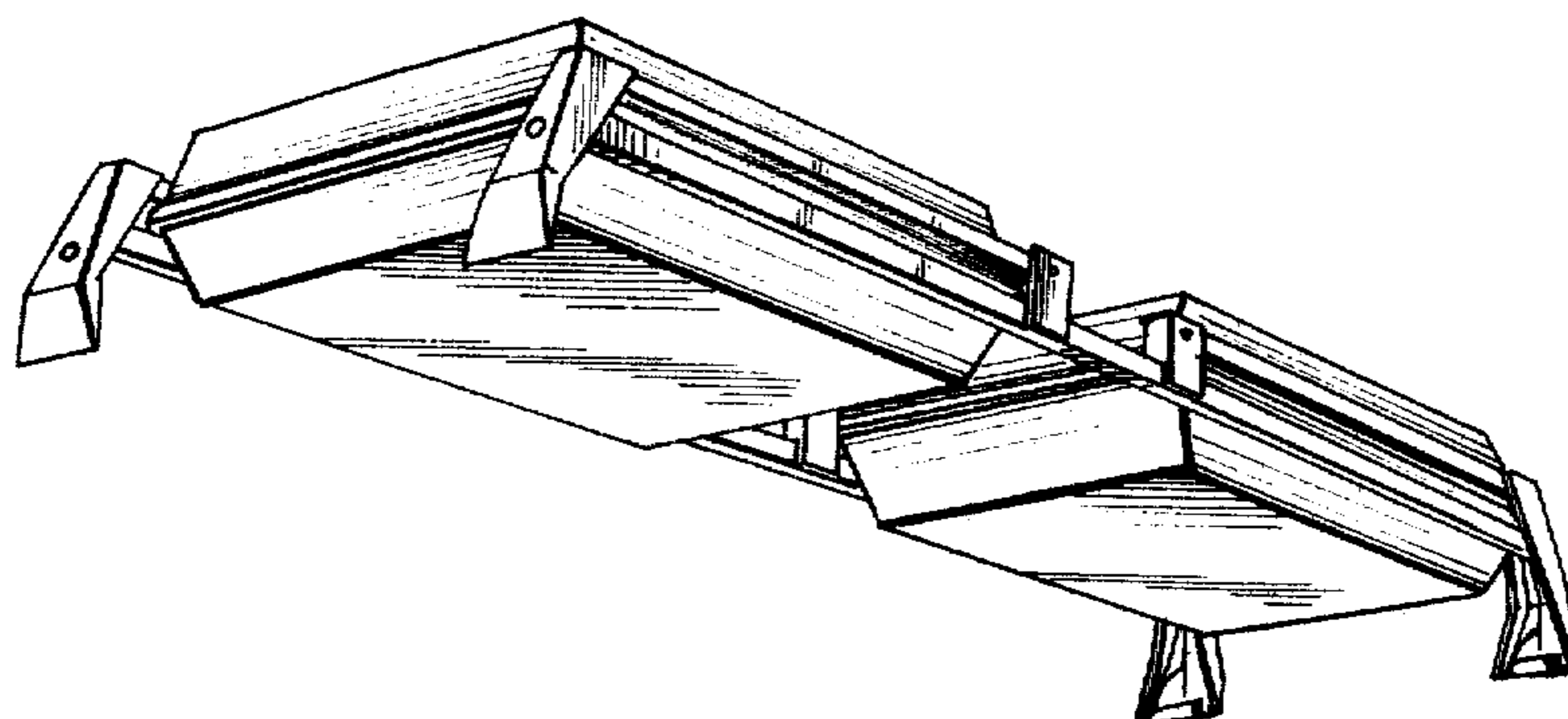

FIG. 3

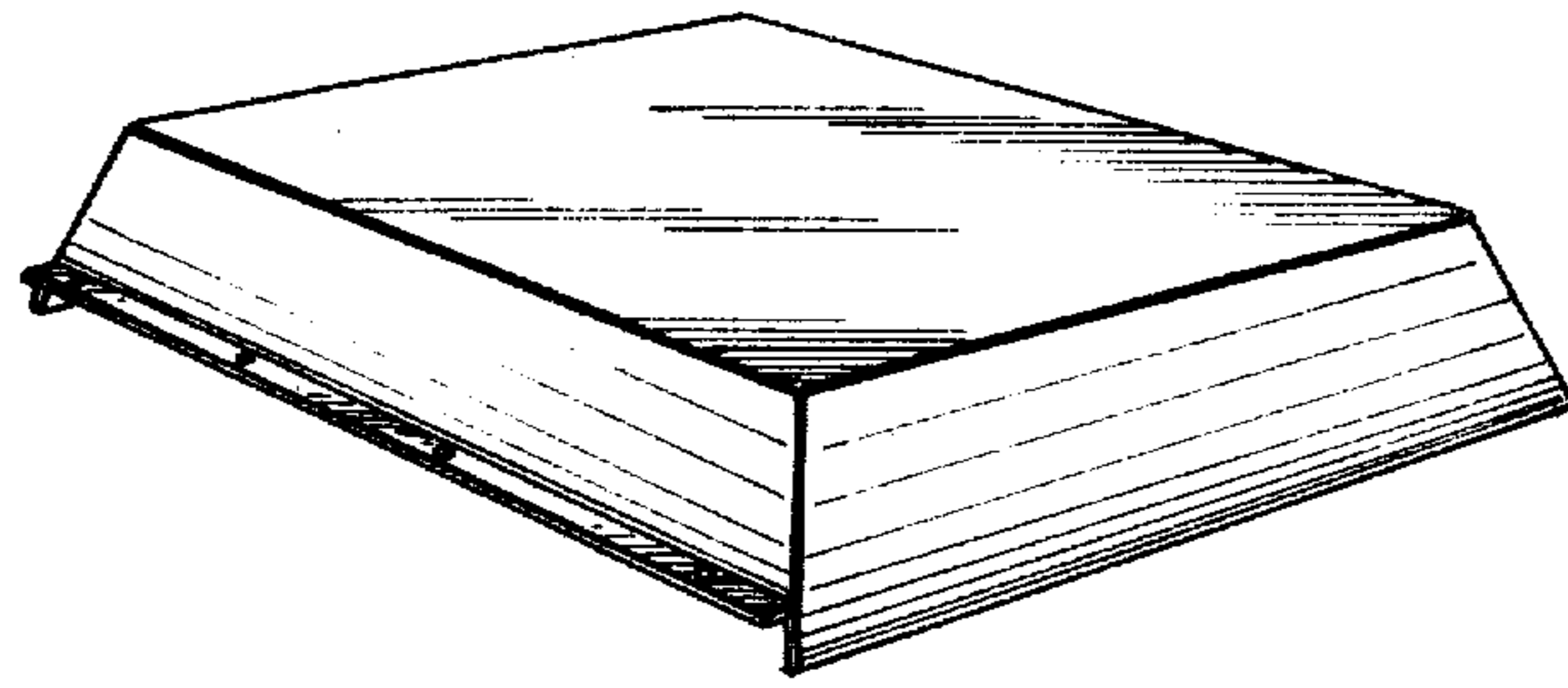

FIG. 4

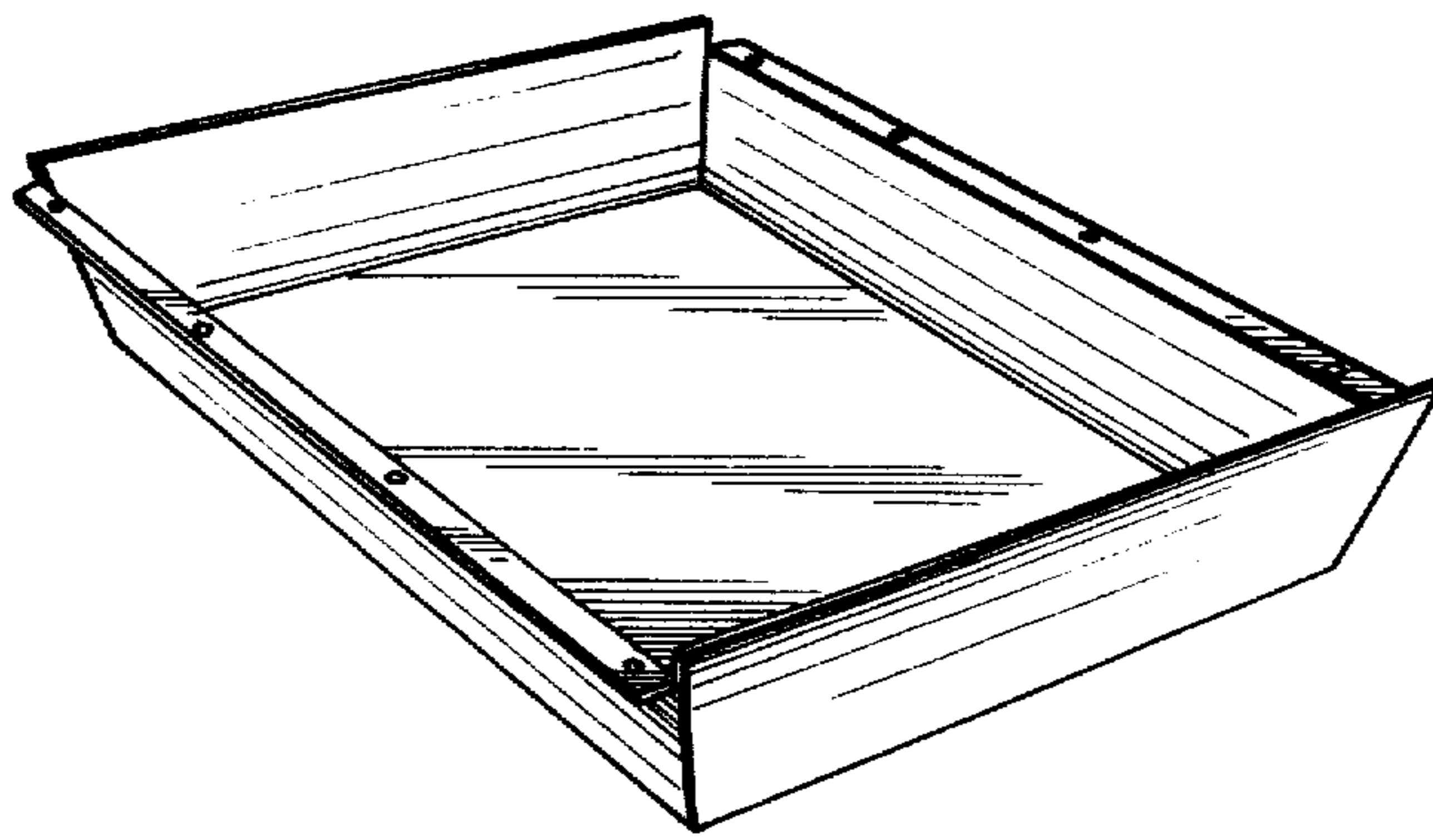

FIG. 5