

[54] **GUIDE PLATE FOR A MULTIPLE SPINDLE ATTACHMENT FOR DRILLING AND TAPPING MACHINES**

[75] Inventor: **Eiji Miyakawa, Tokyo, Japan**

[73] Assignee: **Miyakawa Industry Co., Ltd., Seki, Japan**

[**] Term: **14 Years**

[21] Appl. No.: **143,220**

[22] Filed: **Apr. 24, 1980**

[51] Int. Cl. **D15-09**

[52] U.S. Cl. **D15/132; D15/138**

[58] Field of Search **D15/132, 138; 408/46, 408/241 R, 241 G; 74/665 GA**

[56] **References Cited**

U.S. PATENT DOCUMENTS

2,441,722 5/1948 Schultz 74/665 GA
3,083,593 4/1963 Cotter 408/241

Primary Examiner—B. J. Bullock
Attorney, Agent, or Firm—Jordan and Hamburg

[57] **CLAIM**

The ornamental design for a guide plate for a multiple spindle attachment for drilling and tapping machines, as shown.

DESCRIPTION

FIG. 1 is a front view of a guide plate for a multiple spindle attachment for drilling and tapping machines showing my new design;

FIG. 2 is a rear view;

FIG. 3 is a side view; and

FIG. 4 is a side view partly in section taken in the direction of the arrows on line 4—4 of FIG. 2.

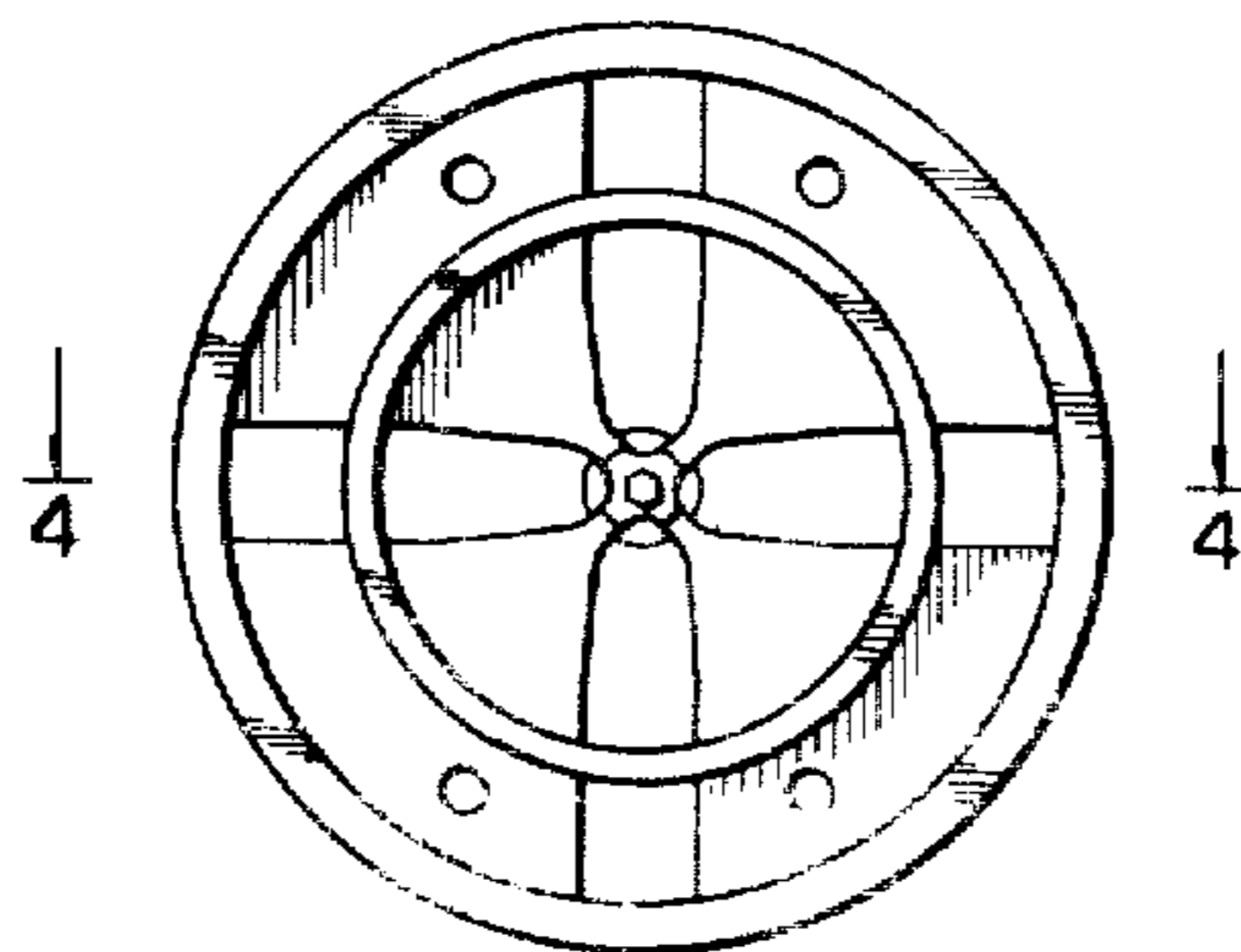
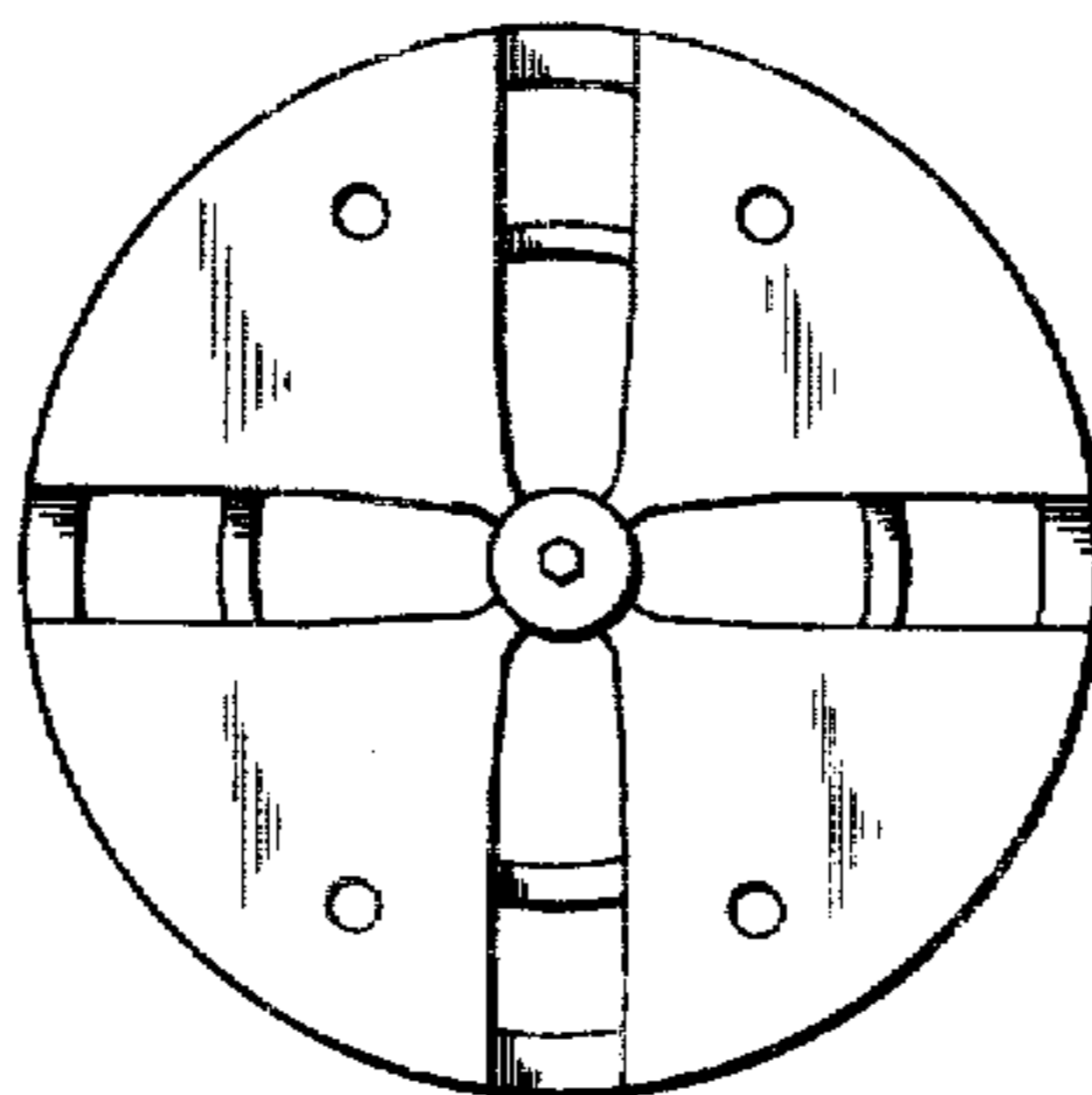

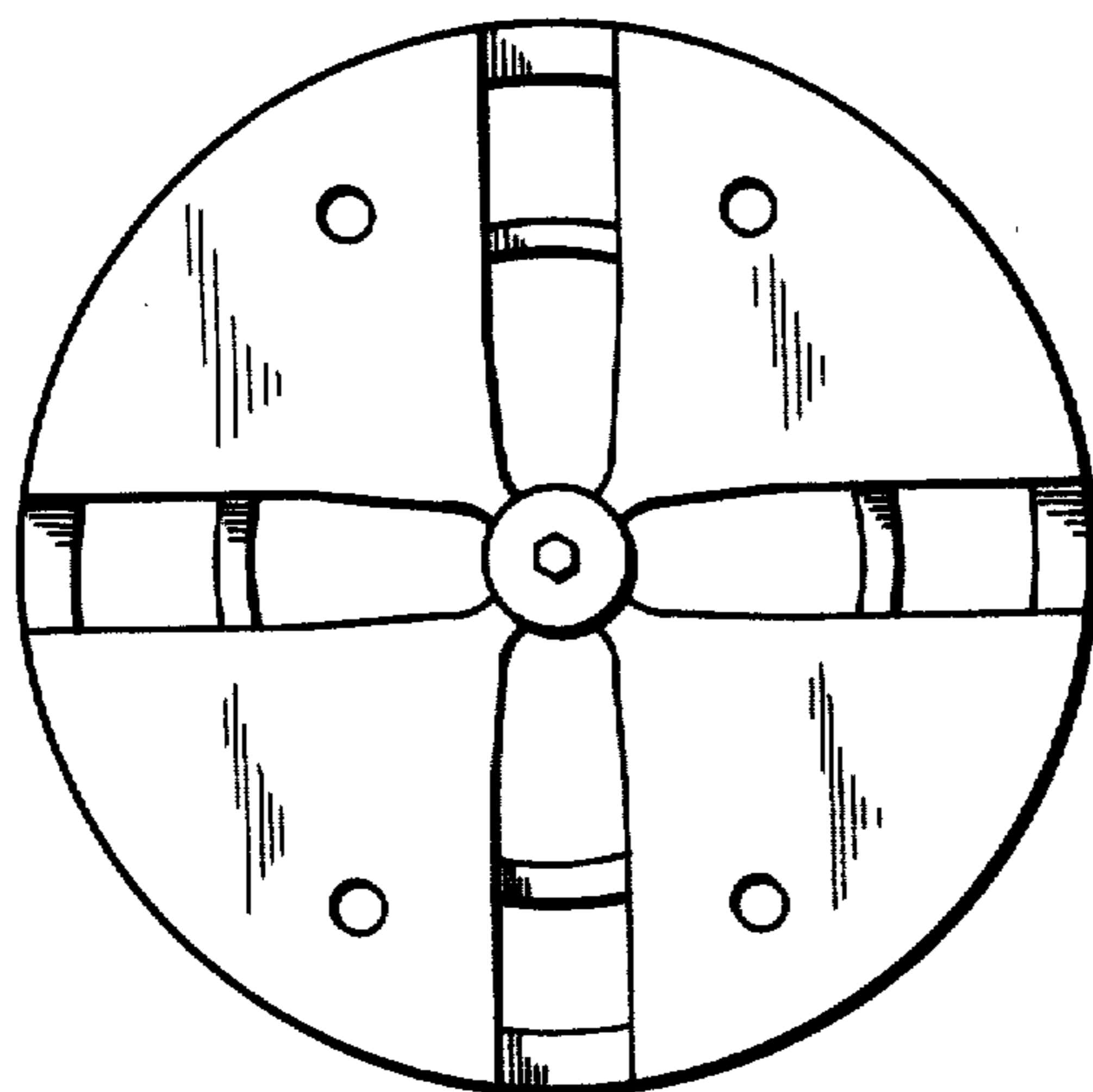

FIG. 1

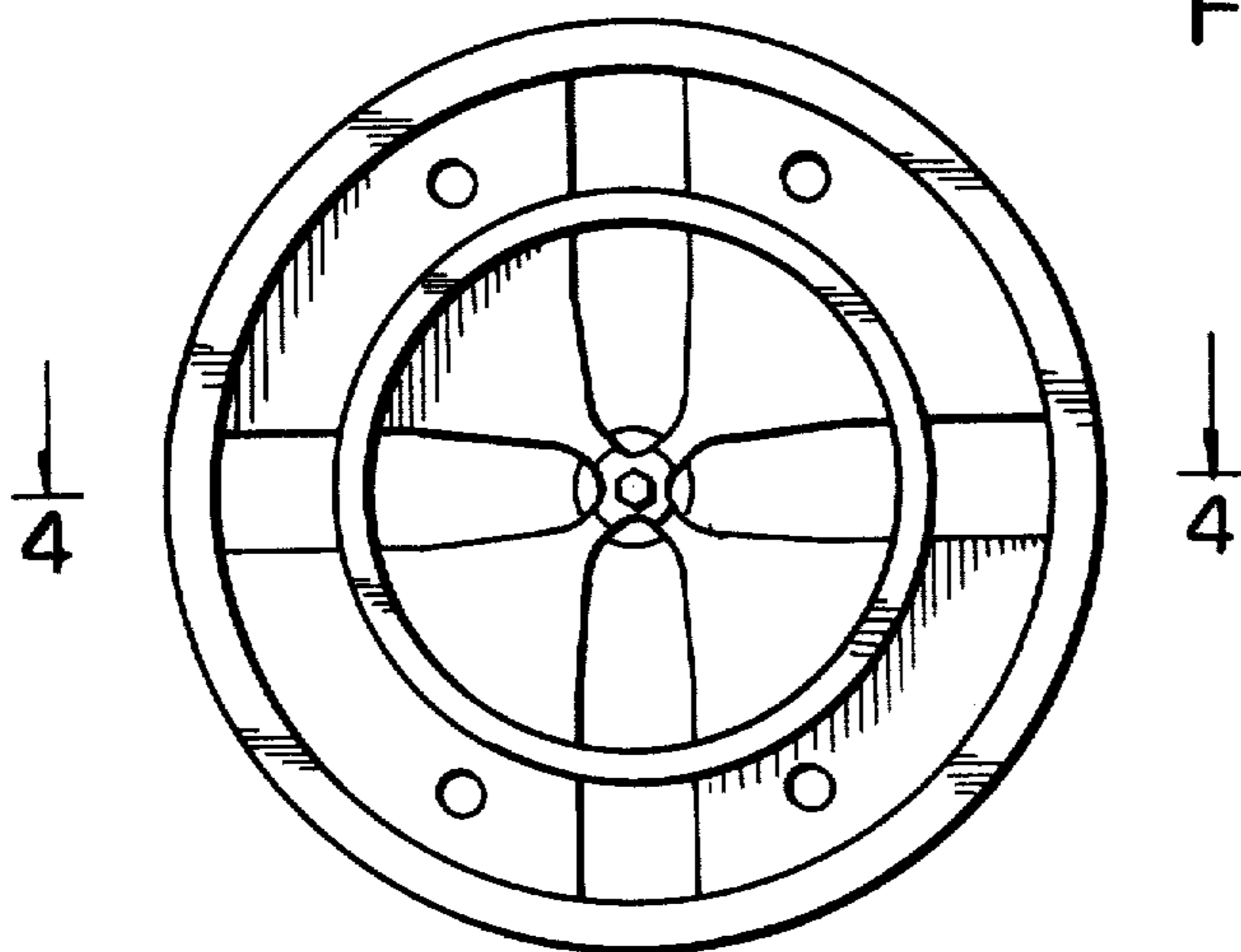

FIG. 2



FIG. 3



FIG. 4