

[54] BATTERY OPERATED LANTERN

[75] Inventor: Kittson Mann, Kowloon, Hong Kong

[73] Assignee: Chung Mei Metal and Plastic Factory Ltd., Kowloon, Hong Kong

[**] Term: 3½ Years

[21] Appl. No.: 99,593

[22] Filed: Dec. 3, 1979

[30] Foreign Application Priority Data

Jun. 19, 1979 [GB] United Kingdom 990349

[51] Int. Cl. D26-02

[52] U.S. Cl. D26/44; D26/48

[58] Field of Search D26/37-50; 362/157, 183, 184, 186, 187, 188, 189, 190, 191, 192, 194-208

[56] References Cited

U.S. PATENT DOCUMENTS

D. 162,578	3/1951	Potekin	D26/48
3,015,719	1/1962	Kirkman	D26/44
3,944,805	3/1976	Moore	362/194

Primary Examiner—Susan J. Lucas
Attorney, Agent, or Firm—Marvin Feldman; Stephen E. Feldman

[57] CLAIM

The ornamental design for a battery operated lantern, substantially as shown and described.

DESCRIPTION

FIG. 1 is a front elevational view of a battery operated lantern showing my new design; FIG. 2 is a rear elevational view thereof; FIG. 3 is a top plan view thereof; FIG. 4 is a side elevational view thereof; and FIG. 5 is a bottom plan view thereof.

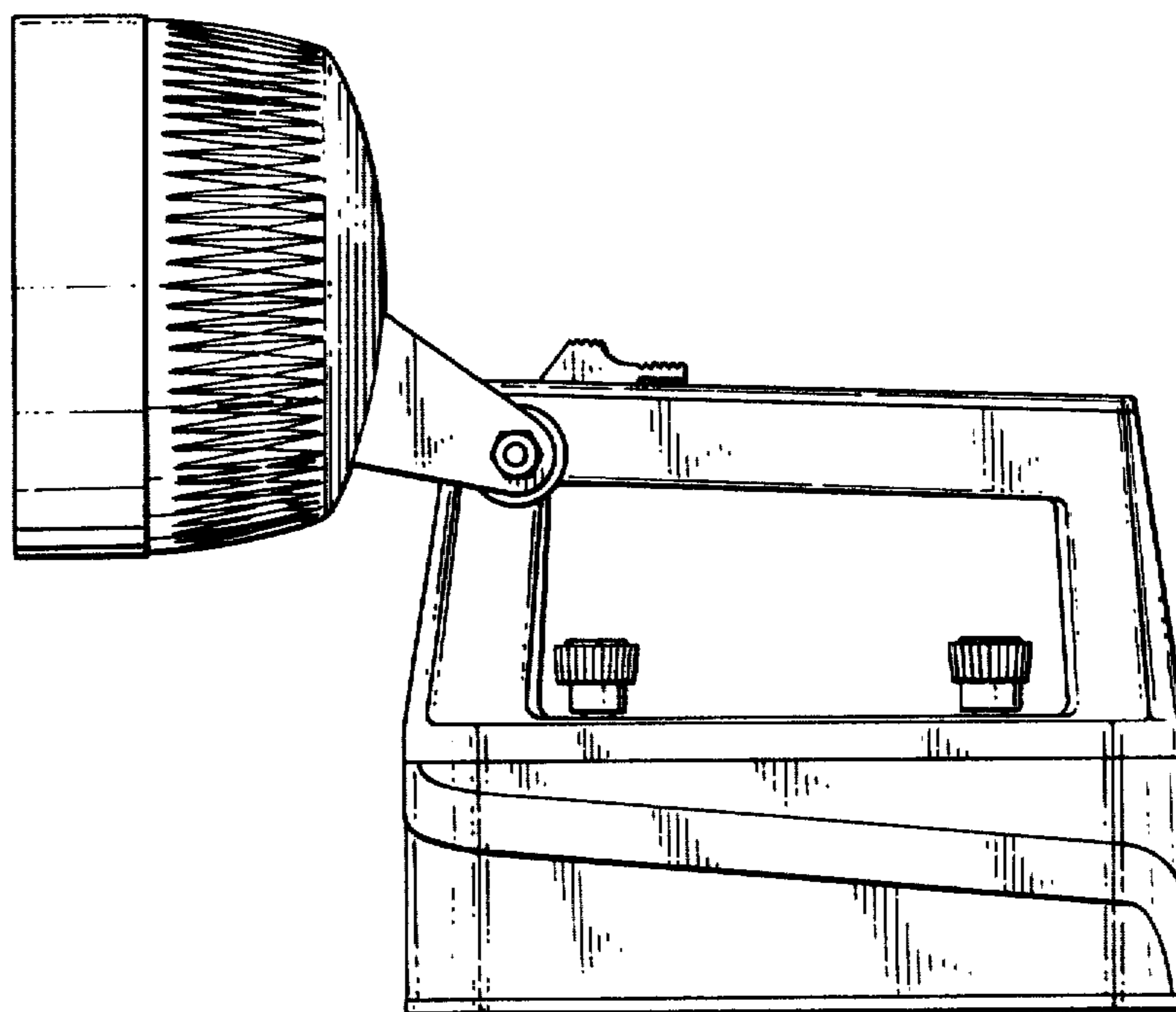

FIG. 1

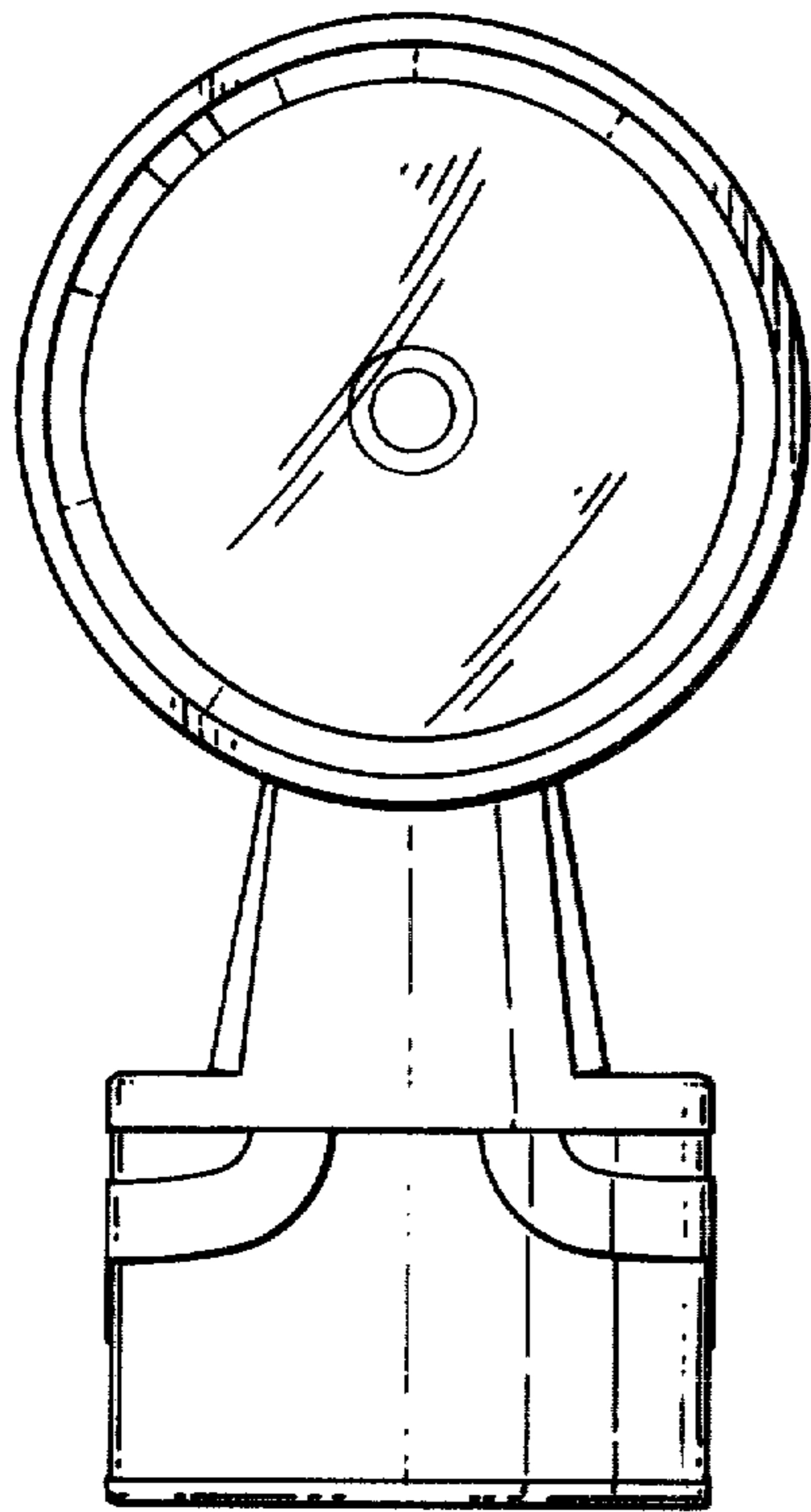

FIG. 2

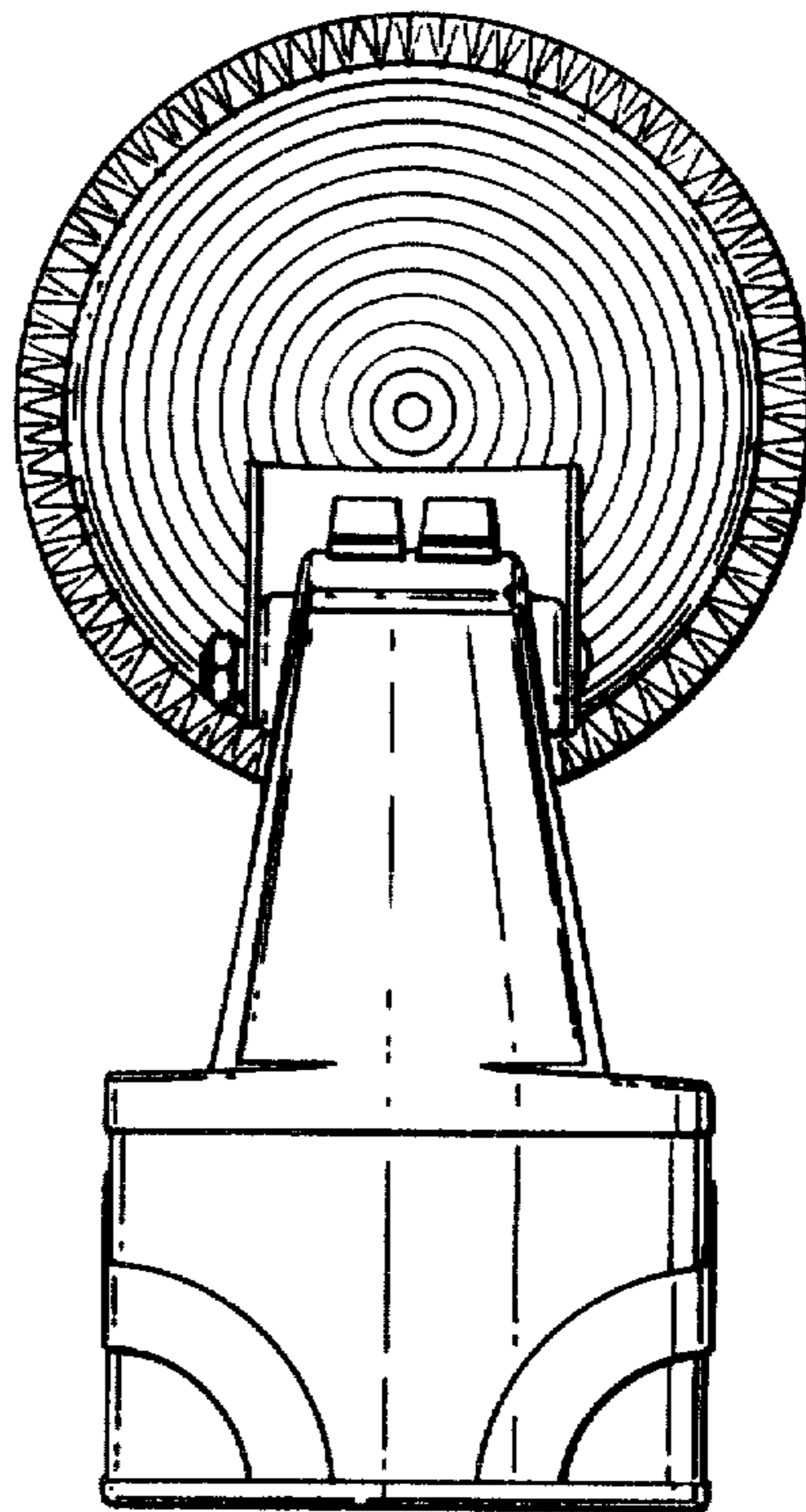

FIG. 3

