

[54] **MOTORCYCLE BY-PASS OIL COOLER**

[75] Inventor: **Ytzhak Gewelber**, La Mirada, Calif.

[73] Assignee: **Lockhart Industries, Inc.**,
Paramount, Calif.

[**] Term: **14 Years**

[21] Appl. No.: **157,548**

[22] Filed: **Jun. 9, 1980**

[51] Int. Cl. **D15-01**

[52] U.S. Cl. **D15/5; D12/114**

[58] Field of Search **D15/5; D12/114;**
180/229, 219; 184/104 B

[56] **References Cited**

U.S. PATENT DOCUMENTS

D. 233,984 12/1974 Hauser D15/5

OTHER PUBLICATIONS

Cycle, 6/79, p. 125, Oil Cooler, center of page.

Primary Examiner—James M. Gandy
Attorney, Agent, or Firm—Fulwider, Patton, Rieber,
Lee & Utecht

[57] **CLAIM**

The ornamental design for a motorcycle by-pass oil cooler, substantially as shown and described.

DESCRIPTION

FIG. 1 is a perspective view of motorcycle by-pass oil cooler, showing my new design;
FIG. 2 is a left side elevational view thereof;
FIG. 3 is front elevational view thereof;
FIG. 4 is a top plan view thereof;
FIG. 5 is a bottom plan view thereof;
FIG. 6 is a perspective view of a motorcycle by-pass oil cooler showing a second embodiment of my new design;
FIG. 7 is a left side elevational view of FIG. 6; and
FIG. 8 is a bottom plan view of FIG. 6, it being understood that the top is identical to the top of the first embodiment shown in FIG. 4.

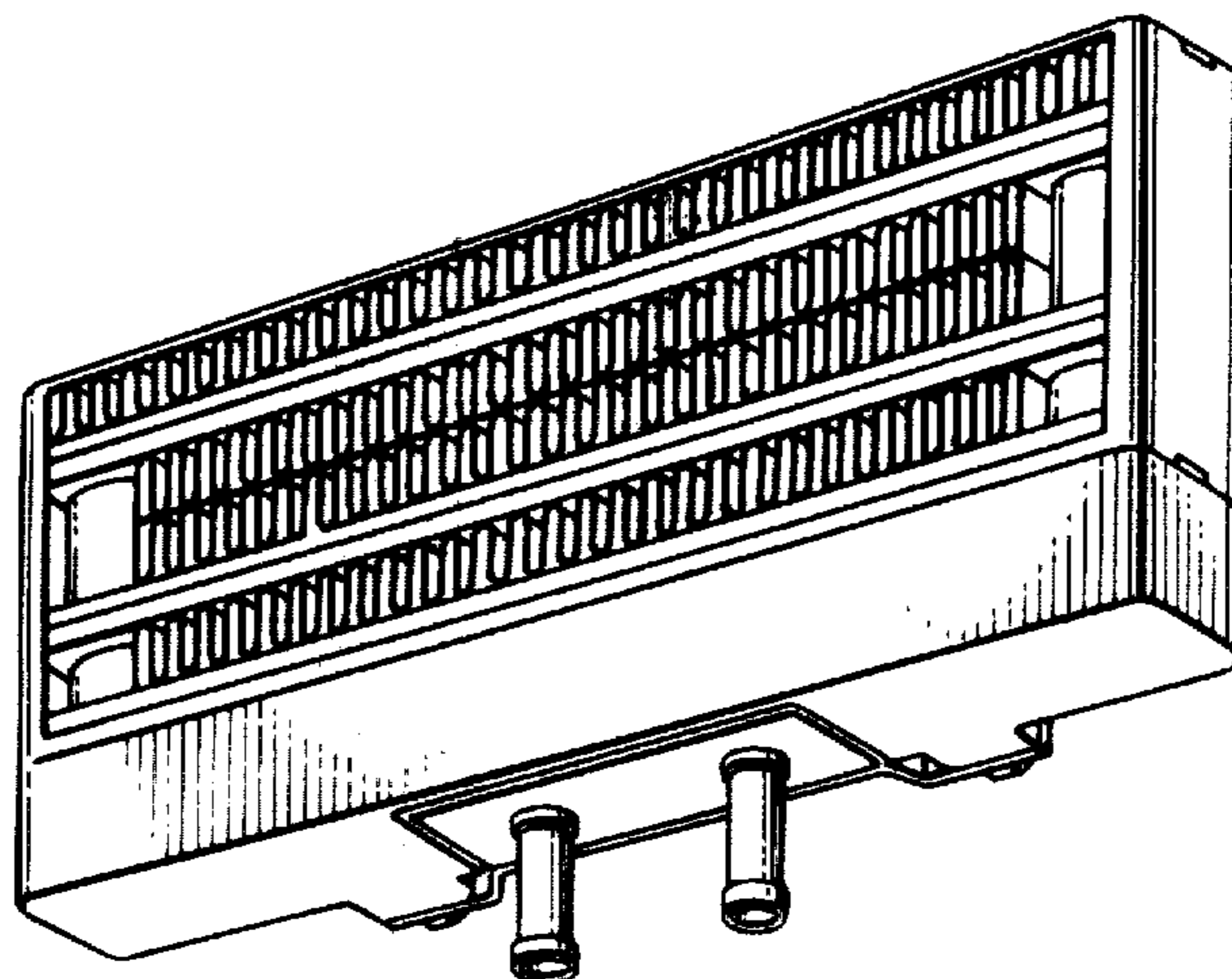

Fig. 1.

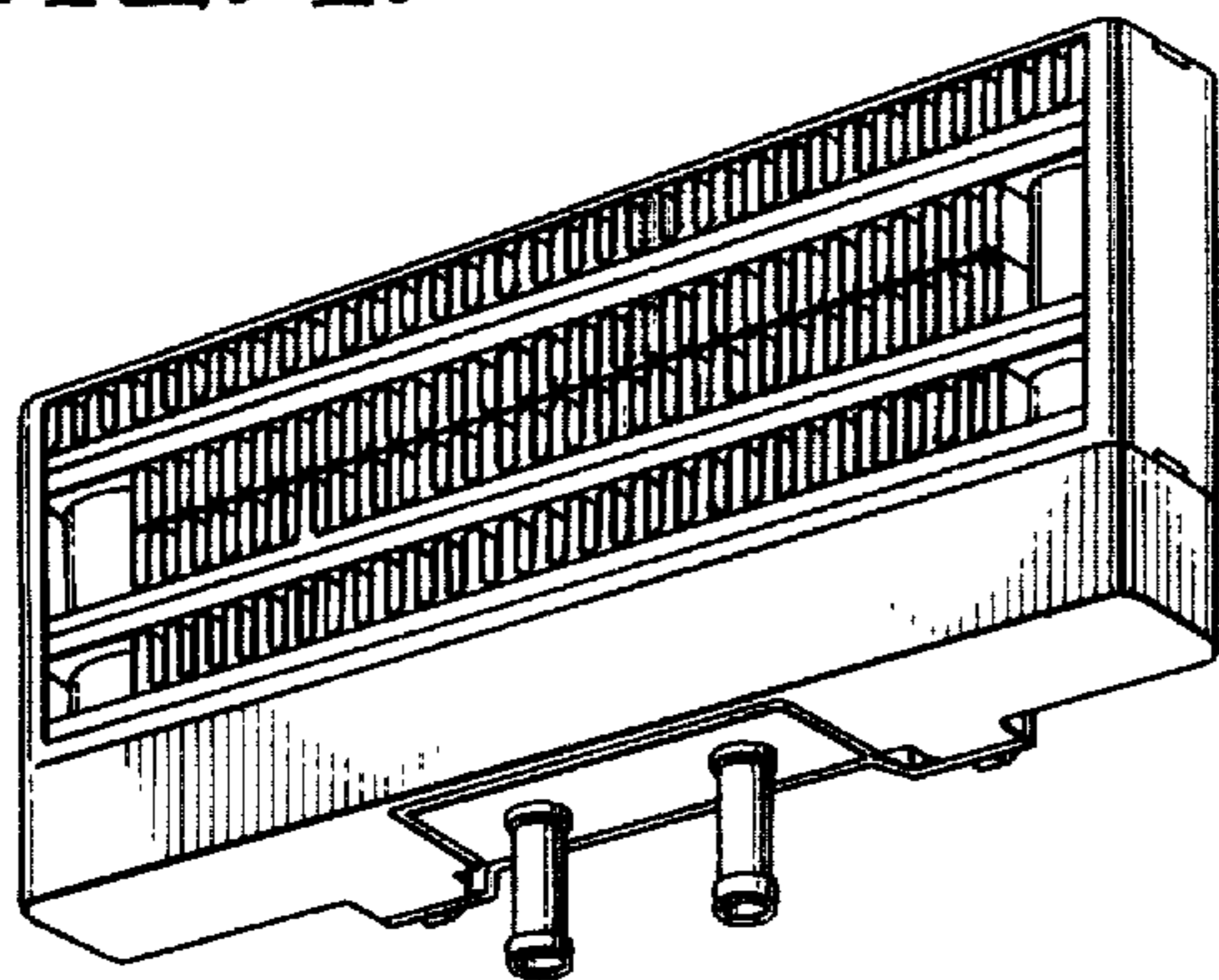

Fig. 2.

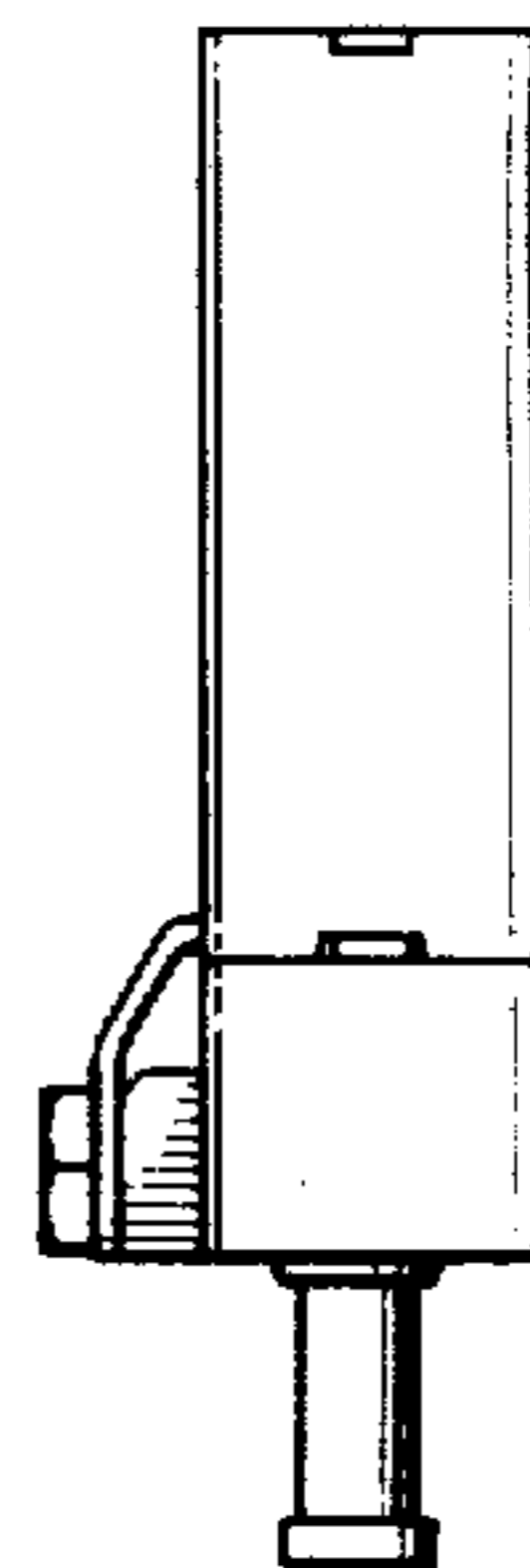

Fig. 3.

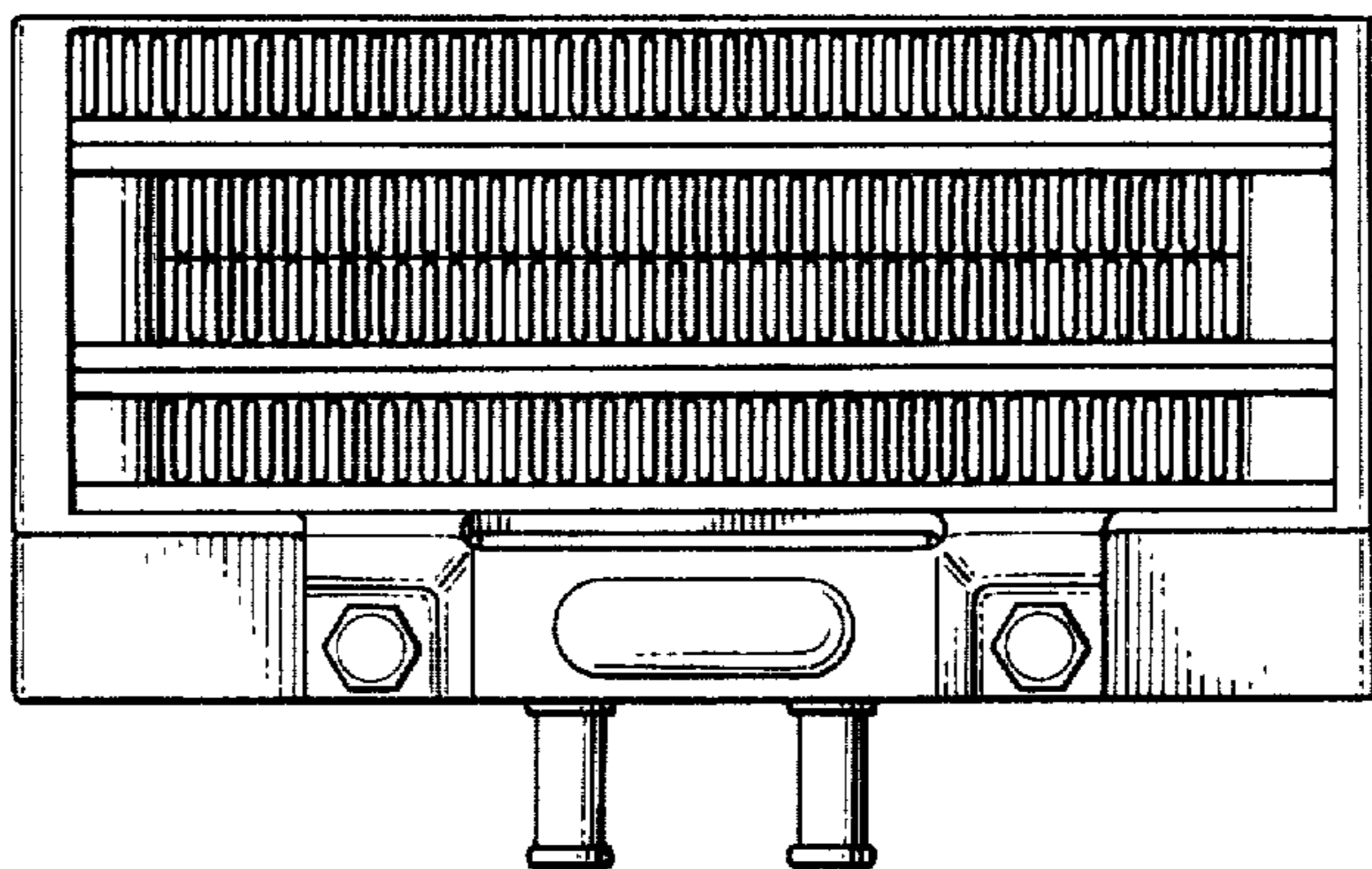

Fig. 4.

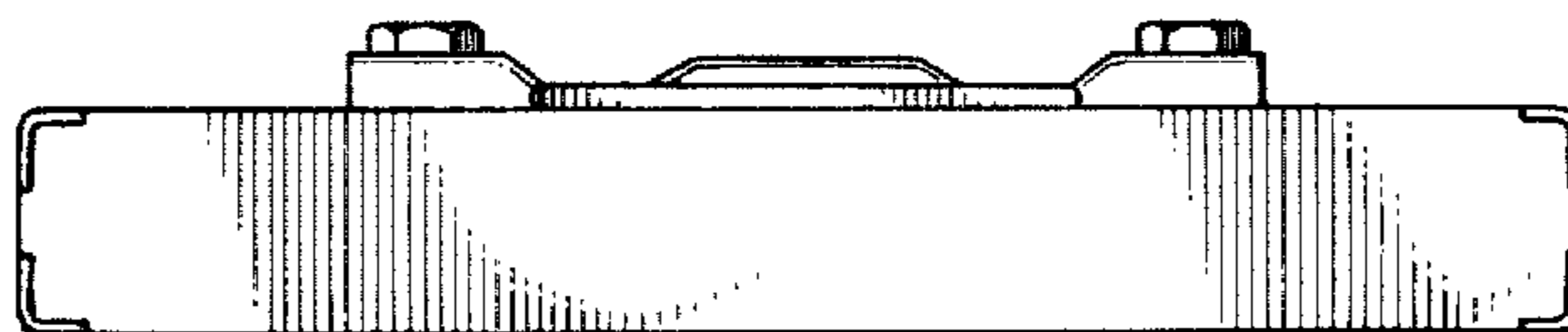

Fig. 5.

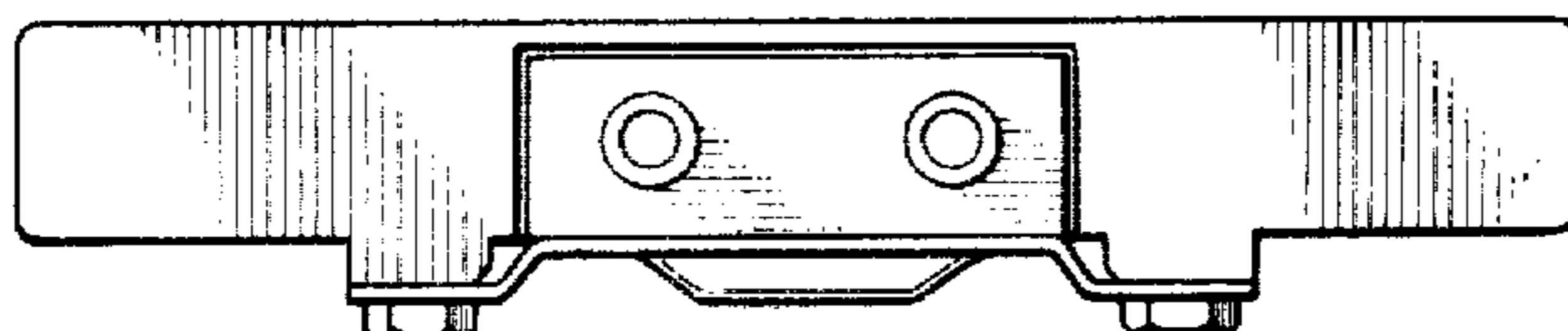

Fig. 6.

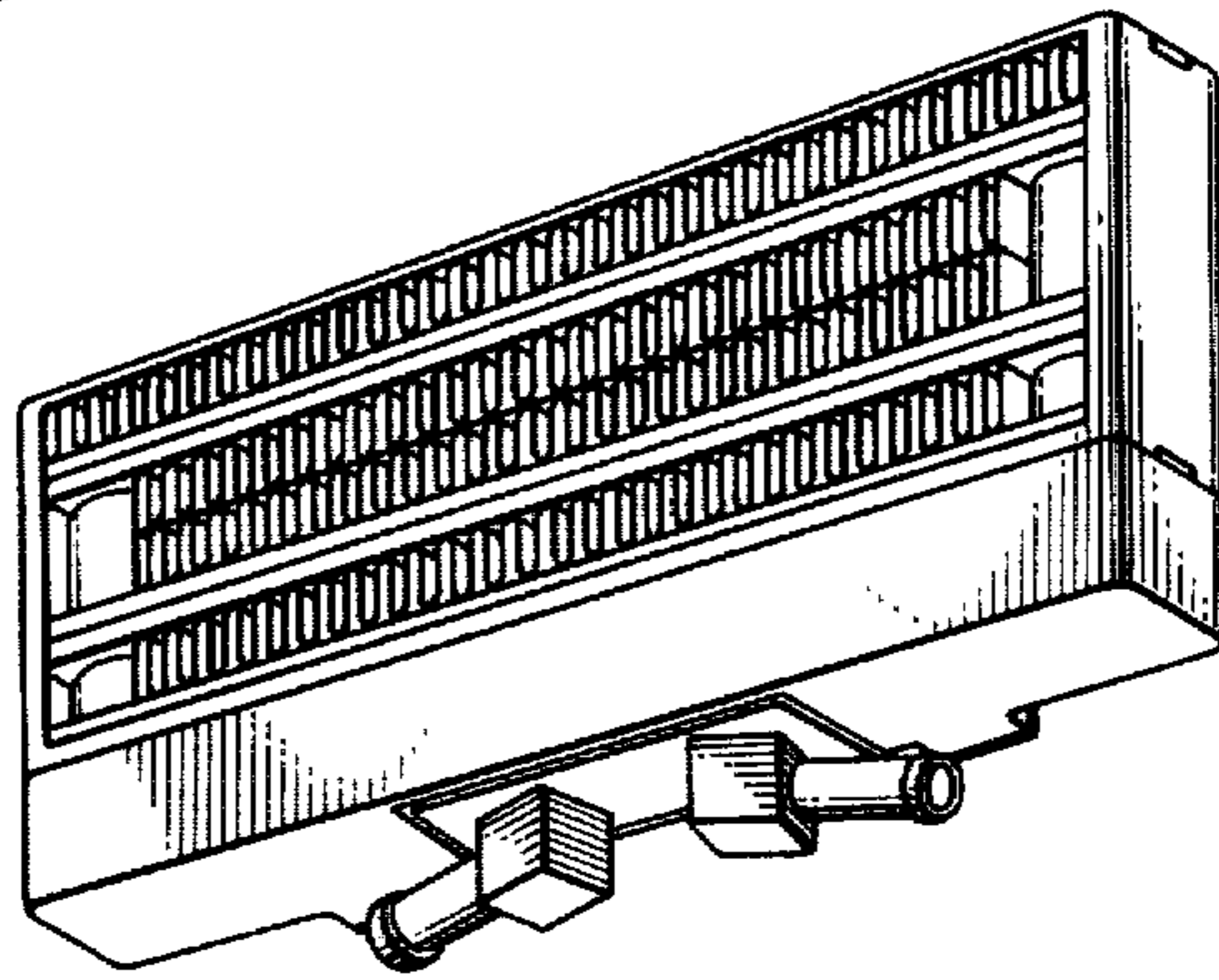

Fig. 7.

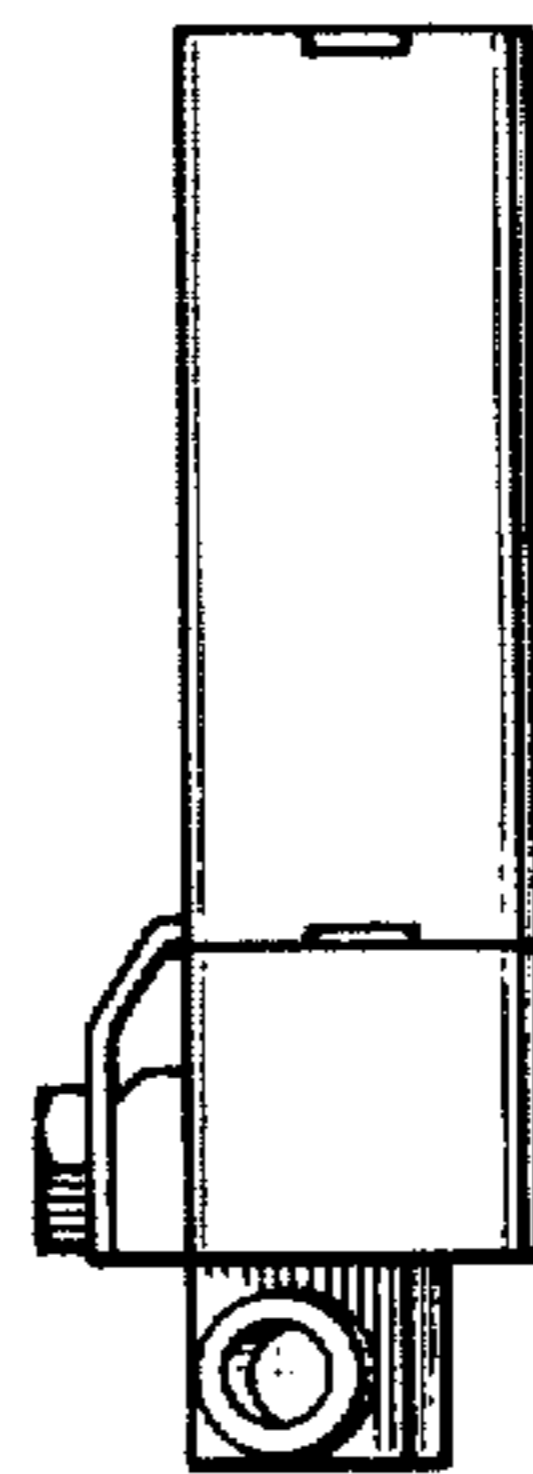

Fig. 8.

