

[54] COMBINED RAISABLE REAR DECK PANEL, WINDOW AND ROOF FOR AN AUTOMOBILE

FOREIGN PATENT DOCUMENTS

719764 12/1954 United Kingdom 296/197

[76] Inventor: Leonard W. Beck, 5 Marchester Dr., Dayton, Ohio 45429

Primary Examiner—James M. Gandy
Attorney, Agent, or Firm—Becker & Becker, Inc.

[**] Term: 14 Years

[57] CLAIM

[21] Appl. No.: 121,634

The ornamental design for a combined raisable rear deck panel, window and roof for an automobile, as shown and described.

[22] Filed: Feb. 14, 1980

DESCRIPTION

[51] Int. Cl. D12-08

FIG. 1 is a side elevational view of a combined raisable rear deck panel, window and roof for an automobile showing my new design;

[52] U.S. Cl. D12/156; D12/196

FIG. 2 is a top plan view thereof;

[58] Field of Search D12/156, 92, 196;

FIG. 3 is a rear elevational view thereof;

296/193, 195, 197, 56, 219, 221

FIG. 4 is a side elevational view thereof in raised condition.

[56] References Cited

U.S. PATENT DOCUMENTS

4,184,709 1/1980 Kim 296/219

The broken lines in the drawing are for illustrative purposes only.

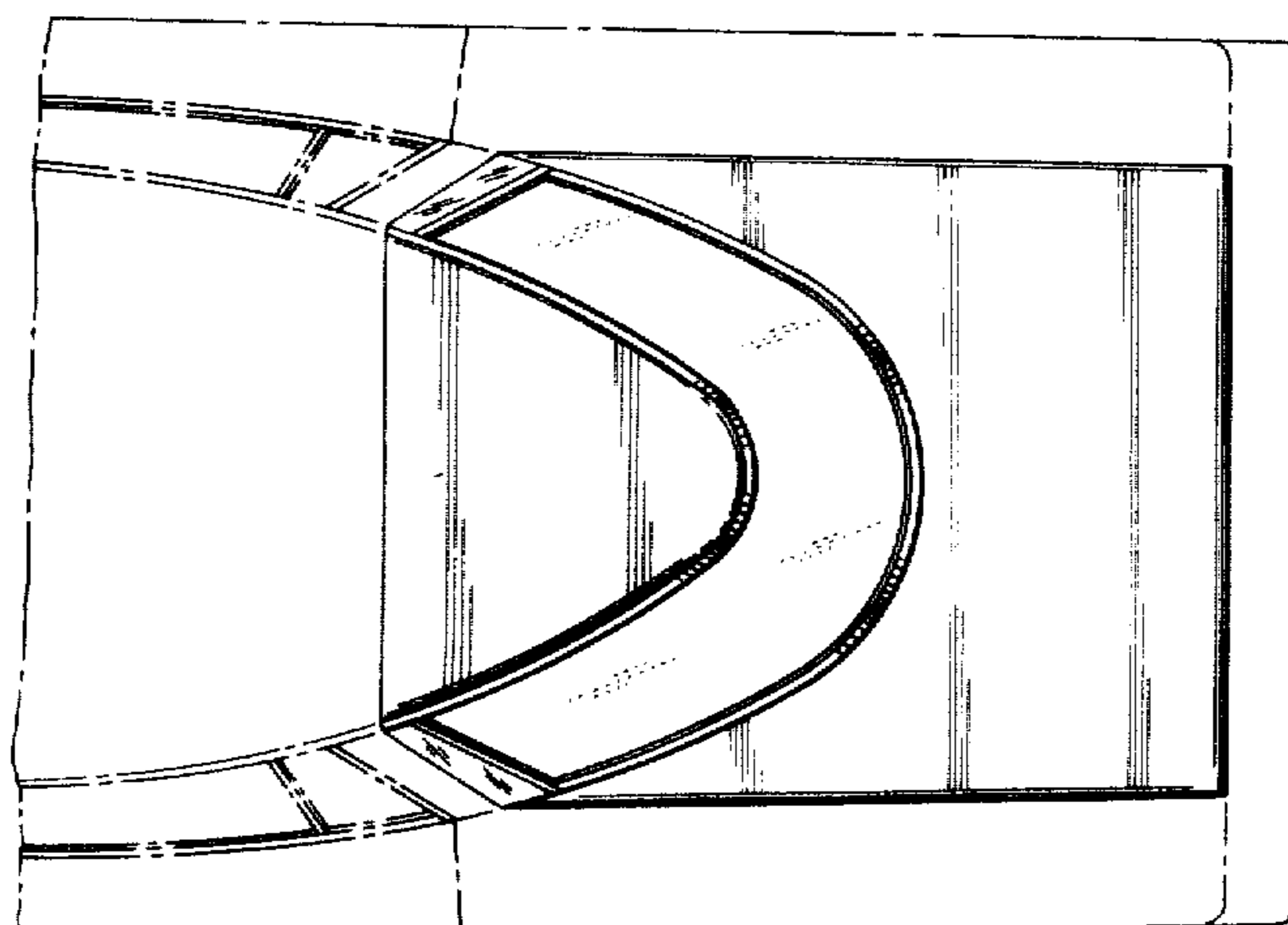
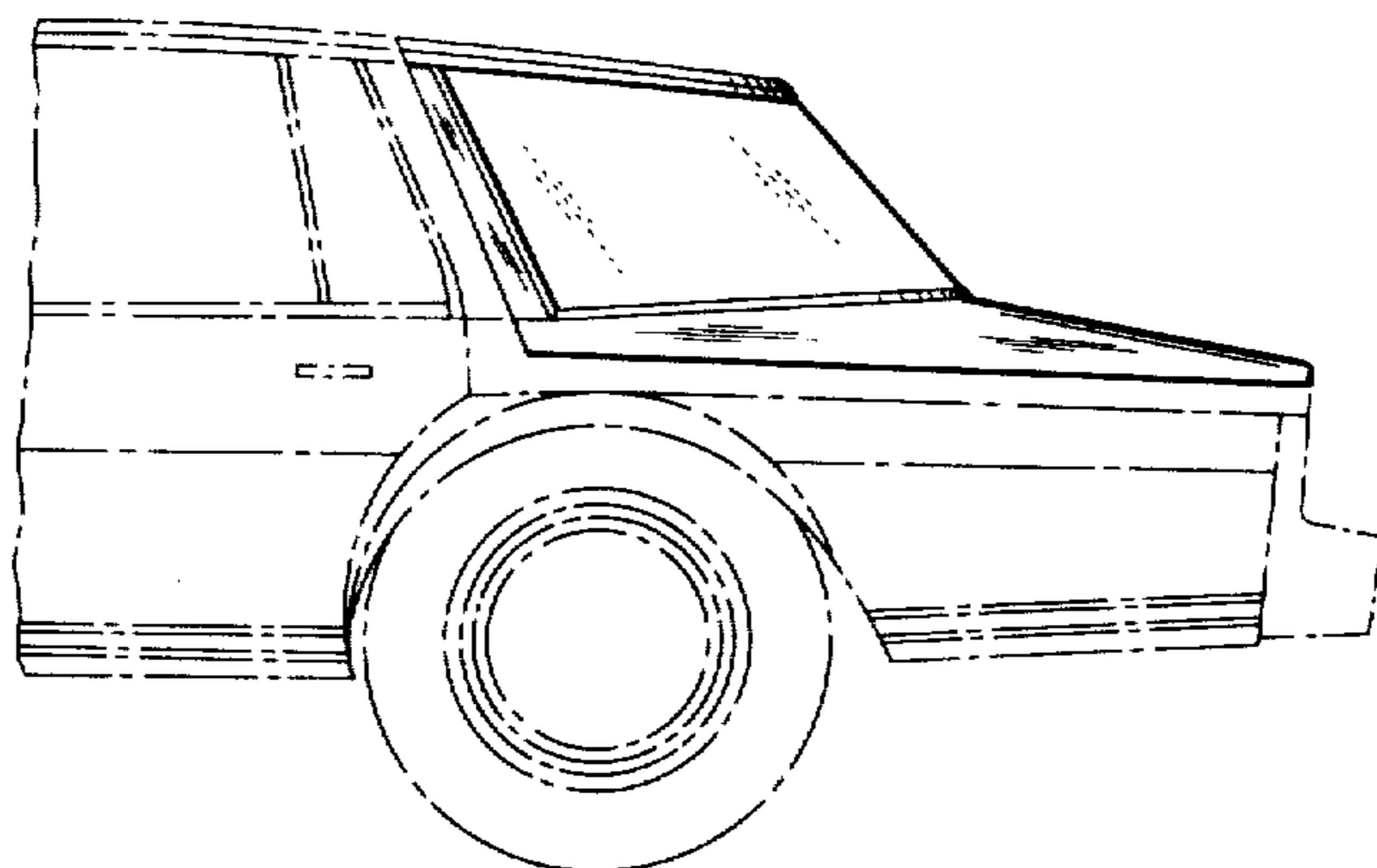

FIG-1

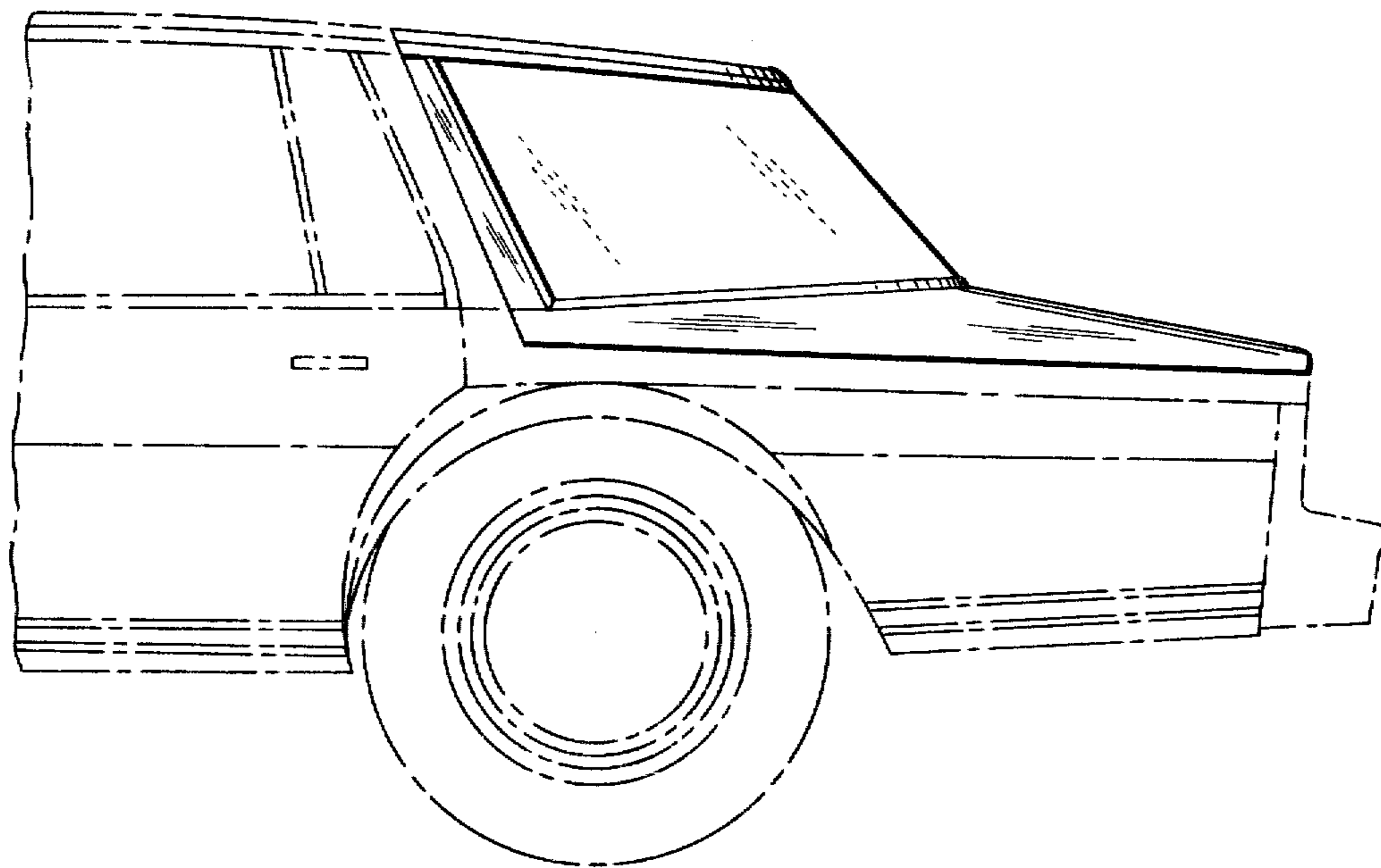

FIG-2

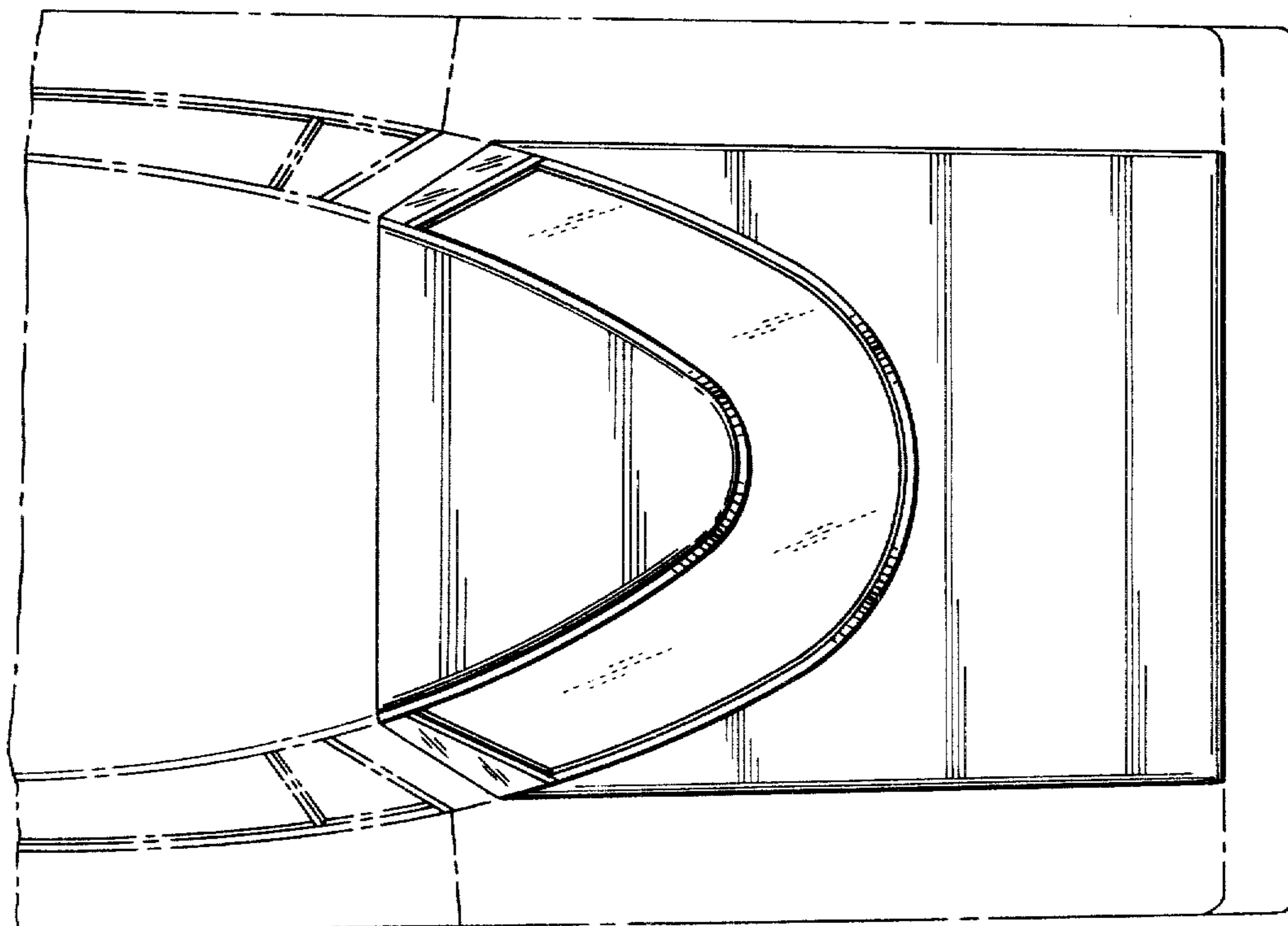

FIG-3

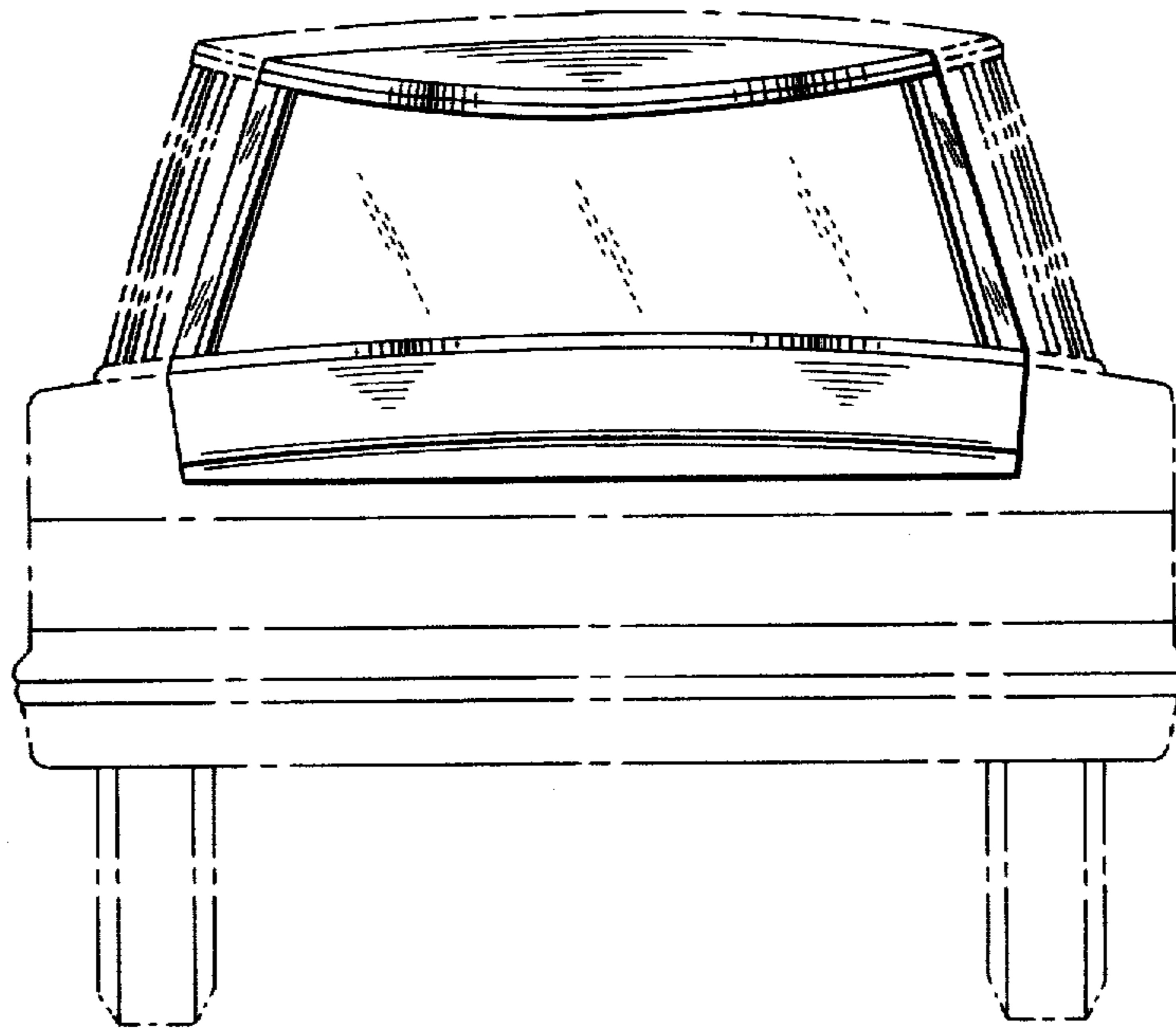

FIG-4

