

[54] COMBINED SNOWMOBILE LUGGAGE CARRIER AND BACKREST

[75] Inventor: Keisuke Yoshida, Huntington Beach, Calif.

[73] Assignee: Yamaha Motor Corporation, U.S.A., Cypress, Calif.

[\*\*] Term: 14 Years

[21] Appl. No.: 157,948

[22] Filed: Jun. 9, 1980

[51] Int. Cl. .... D12-14

[52] U.S. Cl. .... D12/7; D12/158; D6/200

[58] Field of Search .... D12/7, 158; D6/200; 180/182; 224/32 R, 32 A, 33 R, 31

[56] References Cited

U.S. PATENT DOCUMENTS

- 3,537,746 11/1970 Peters ..... 296/78.1
- 3,658,358 4/1972 Baker ..... 180/182
- 3,736,005 5/1973 Wright ..... D12/7

Primary Examiner—James M. Gandy  
Attorney, Agent, or Firm—Freilich, Hornbaker, Wasserman, Rosen & Fernandez

[57] CLAIM

The ornamental design for a combined snowmobile luggage carrier and backrest, as shown.

DESCRIPTION

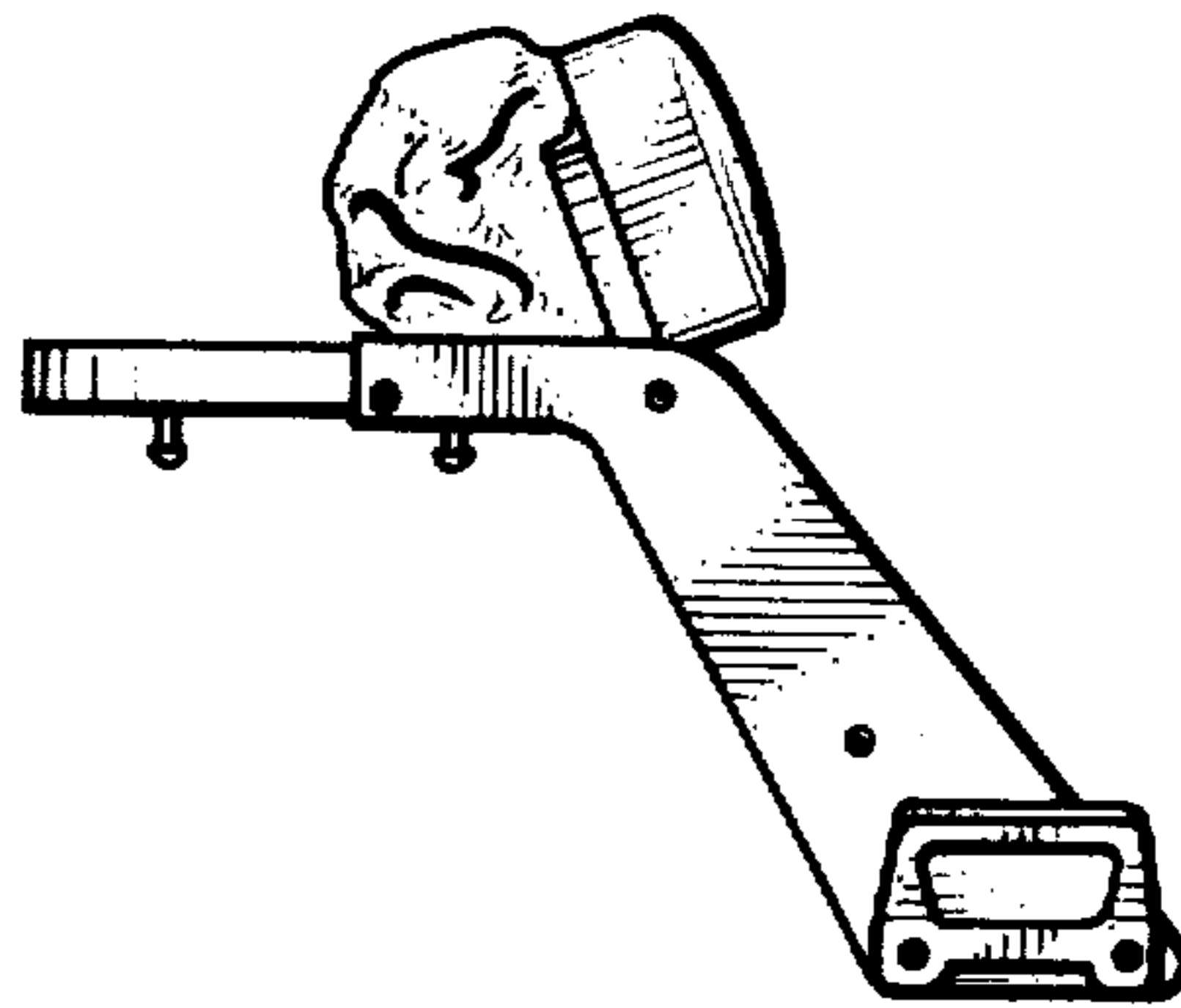
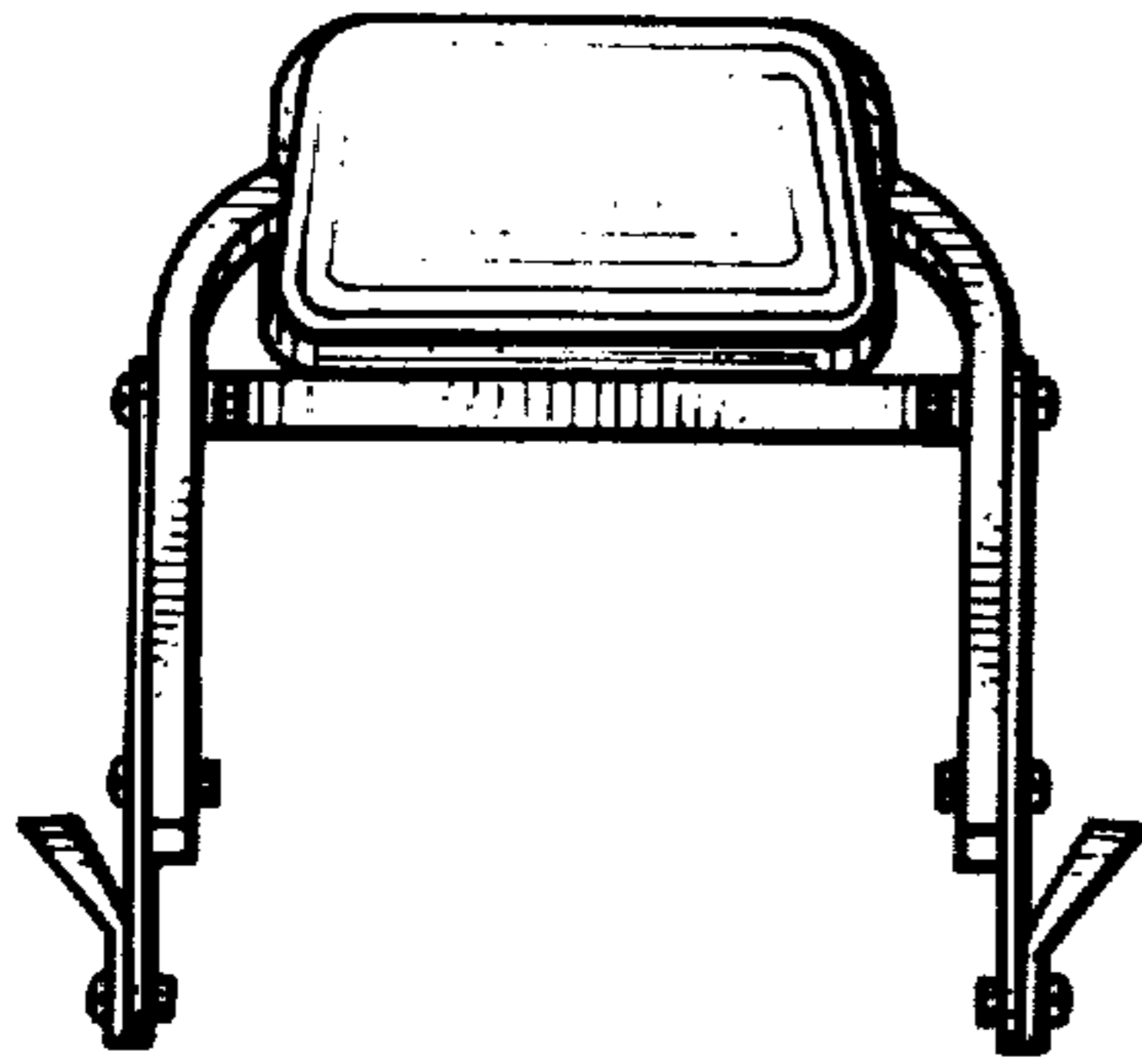
FIG. 1 is a front elevation view of a combined snowmobile luggage carrier and backrest showing my new design.

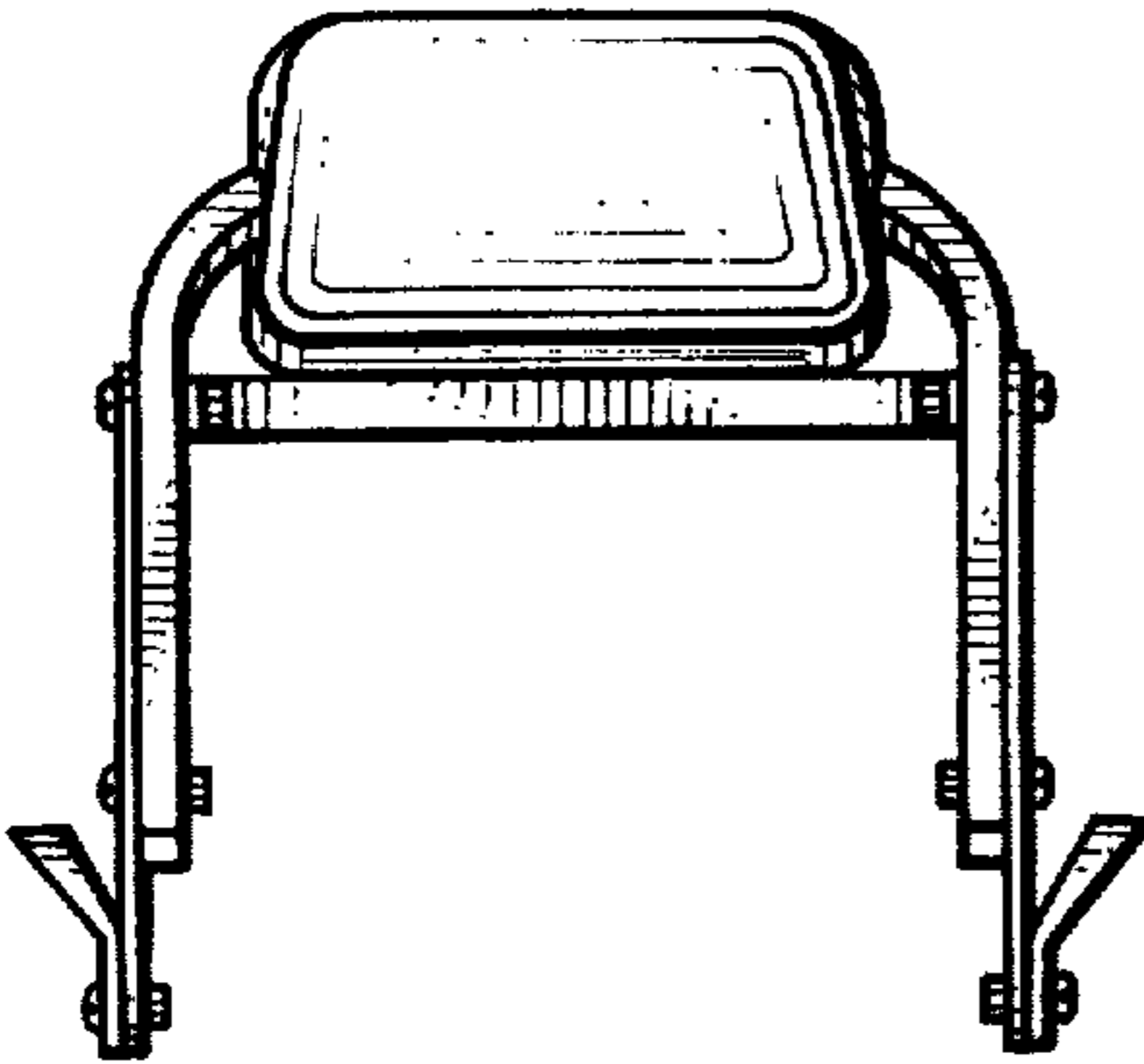
FIG. 2 is a left side elevation view thereof.

FIG. 3 is a rear elevation view thereof.

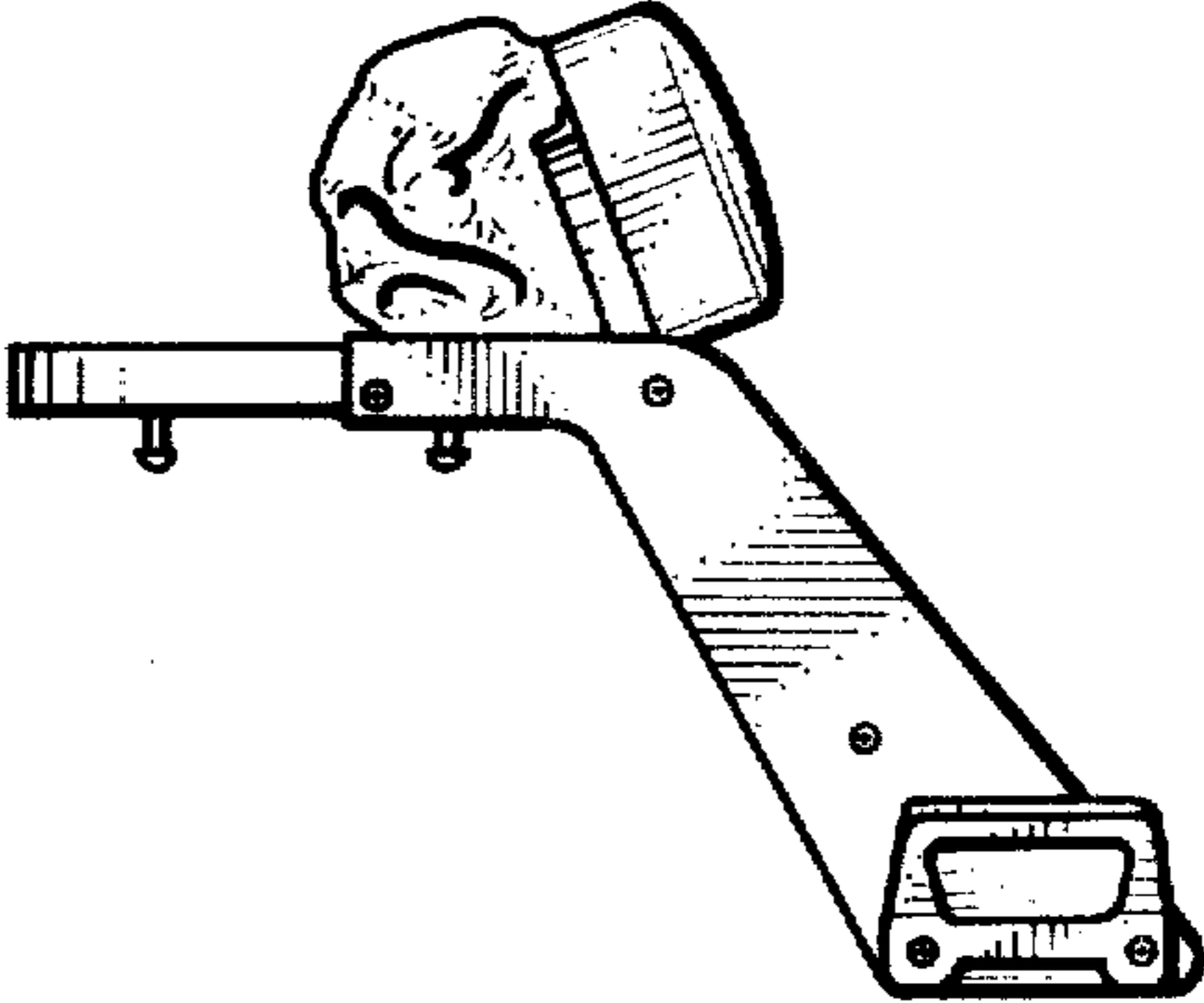
FIG. 4 is a top plan view thereof.

FIG. 5 is a bottom plan view thereof.

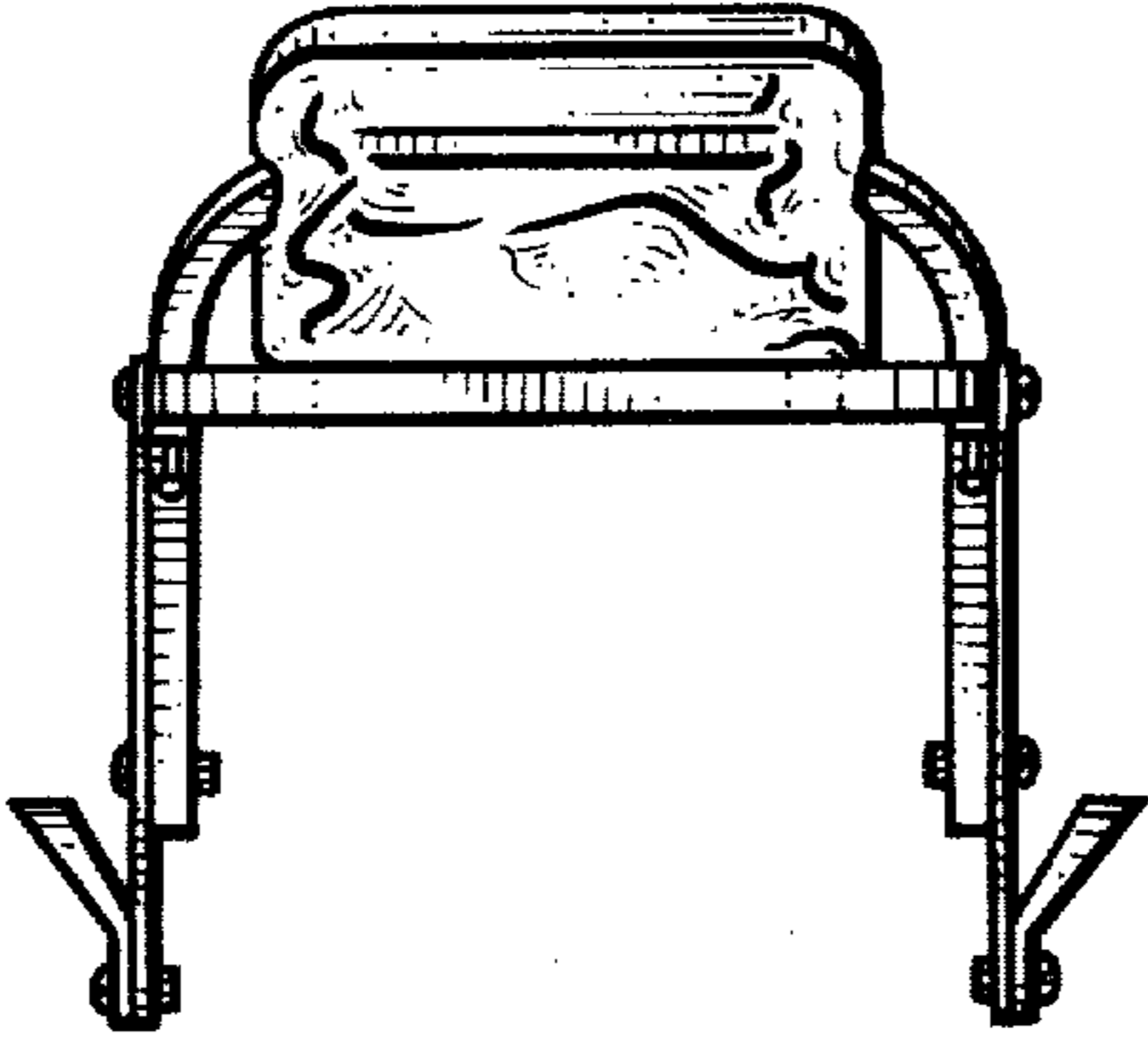




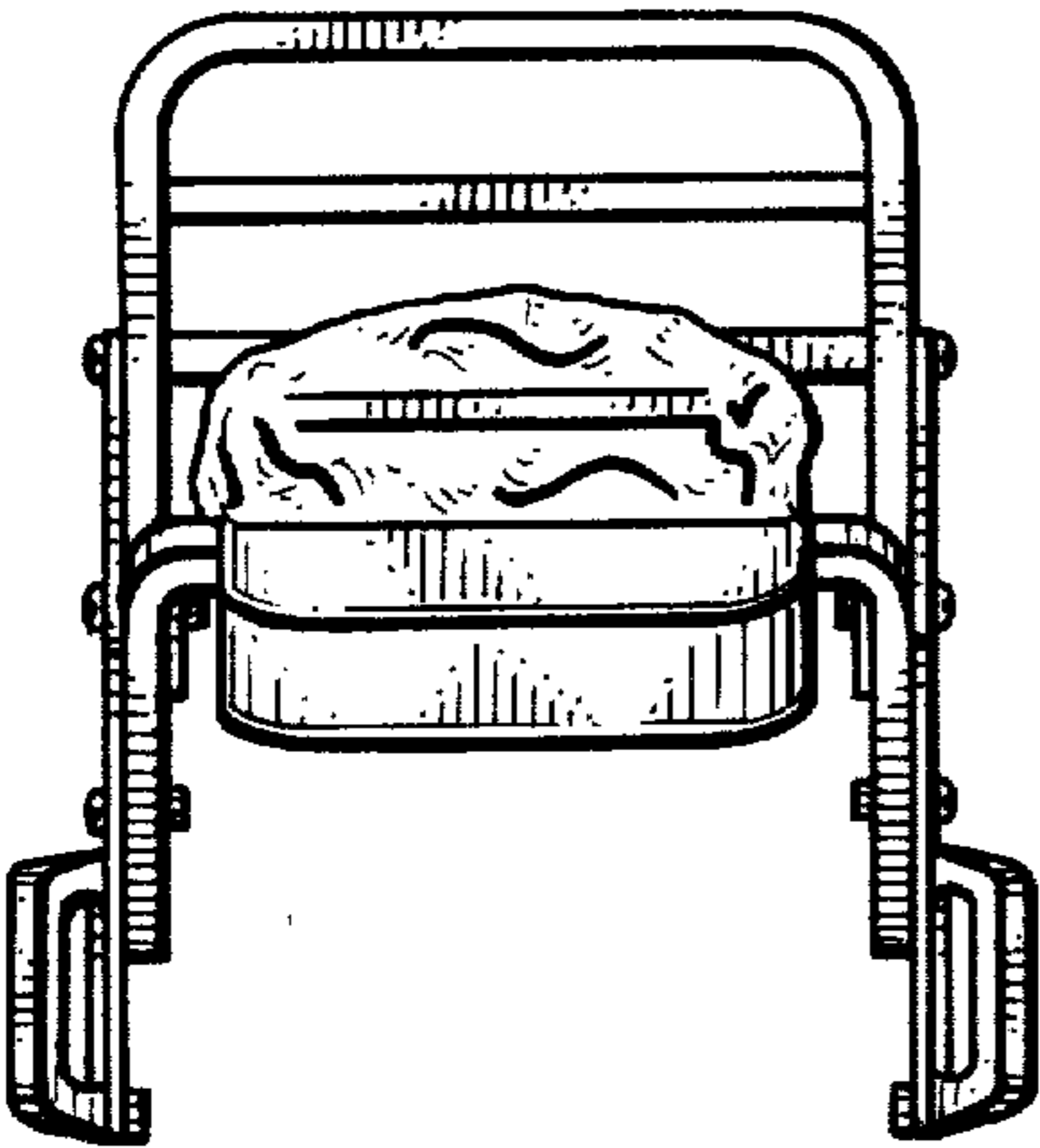
*Fig. 1*



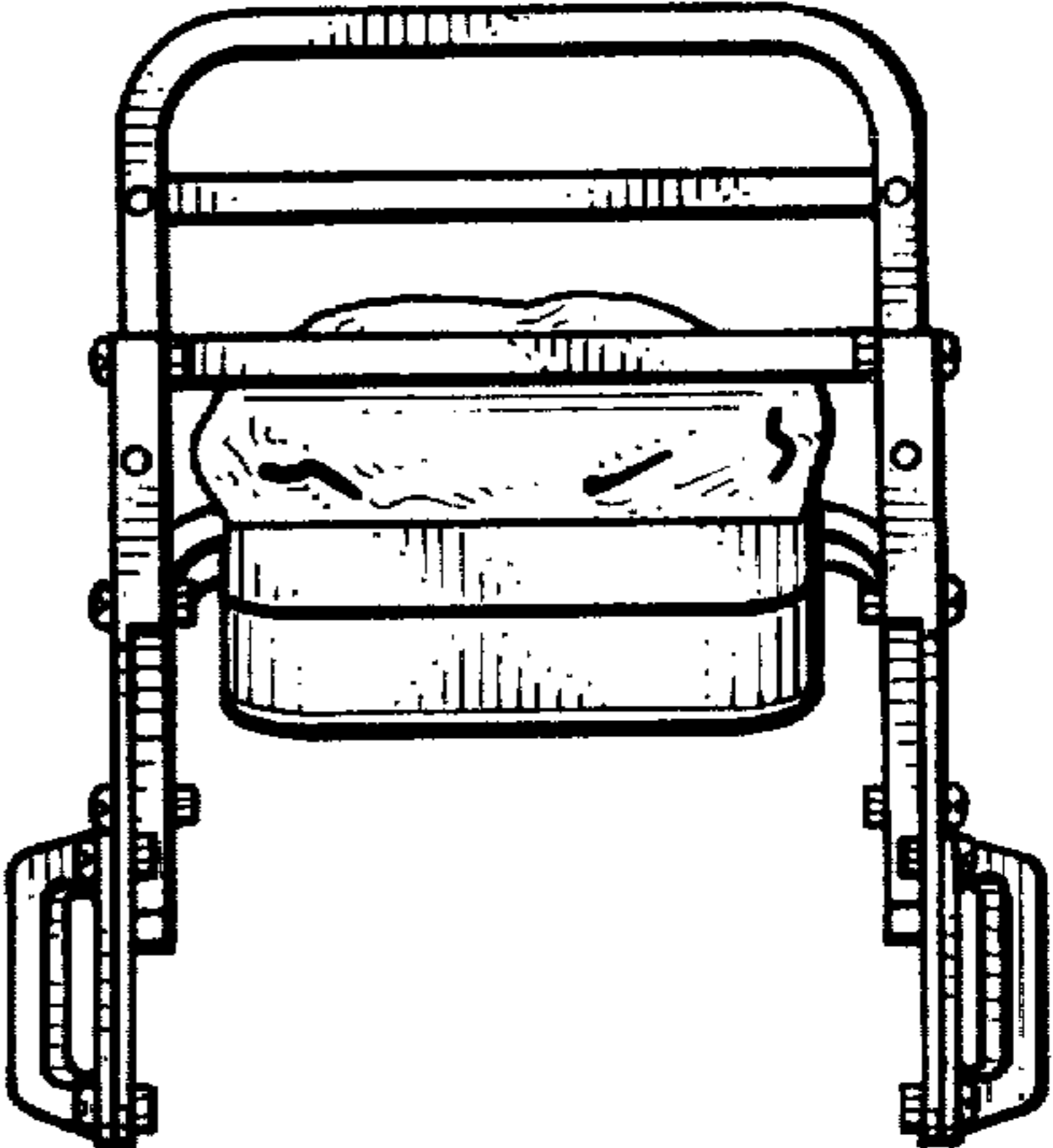
*Fig. 2.*



*Fig. 3.*



*Fig. 4.*



*Fig. 5.*