

[54] OIL PAN GUARD

[75] Inventor: John H. Zimmer, Jr., Maple Grove, Minn.

[73] Assignee: Karrousel Racing Incorporated, Minneapolis, Minn.

[**] Term: 14 Years

[21] Appl. No.: 112,692

[22] Filed: Jan. 14, 1980

[51] Int. Cl. D12-16

[52] U.S. Cl. D12/190; D12/155; 180/69.1

[58] Field of Search D23/41, 42; D12/155, D12/190; 180/69.1, 313

[56] References Cited

U.S. PATENT DOCUMENTS

- D. 187,070 1/1960 Walker D12/190
- D. 187,205 2/1960 Laughlin D23/41

- D. 211,332 6/1968 Norvold D12/155
- D. 213,101 1/1969 Delk, Jr. D12/155
- D. 248,094 6/1978 Nix D12/190
- D. 249,955 10/1978 Vogelsang D23/42
- 3,651,884 3/1972 Dorries 180/69.1
- 3,815,702 6/1974 Paananen 180/69.1
- 3,826,327 7/1974 Stover 180/69.1

Primary Examiner—James R. Largen
Attorney, Agent, or Firm—Nathaniel A. Humphries

[57] CLAIM

The ornamental design for an oil pan guard, substantially as shown.

DESCRIPTION

FIG. 1 is a perspective view of an oil pan guard embodying my new design;
FIG. 2 is a bottom plan view thereof;
FIG. 3 is a right end elevational view thereof;
FIG. 4 is a rear elevational view thereof;
FIG. 5 is a left end elevational view thereof; and
FIG. 6 is a front elevational view thereof.

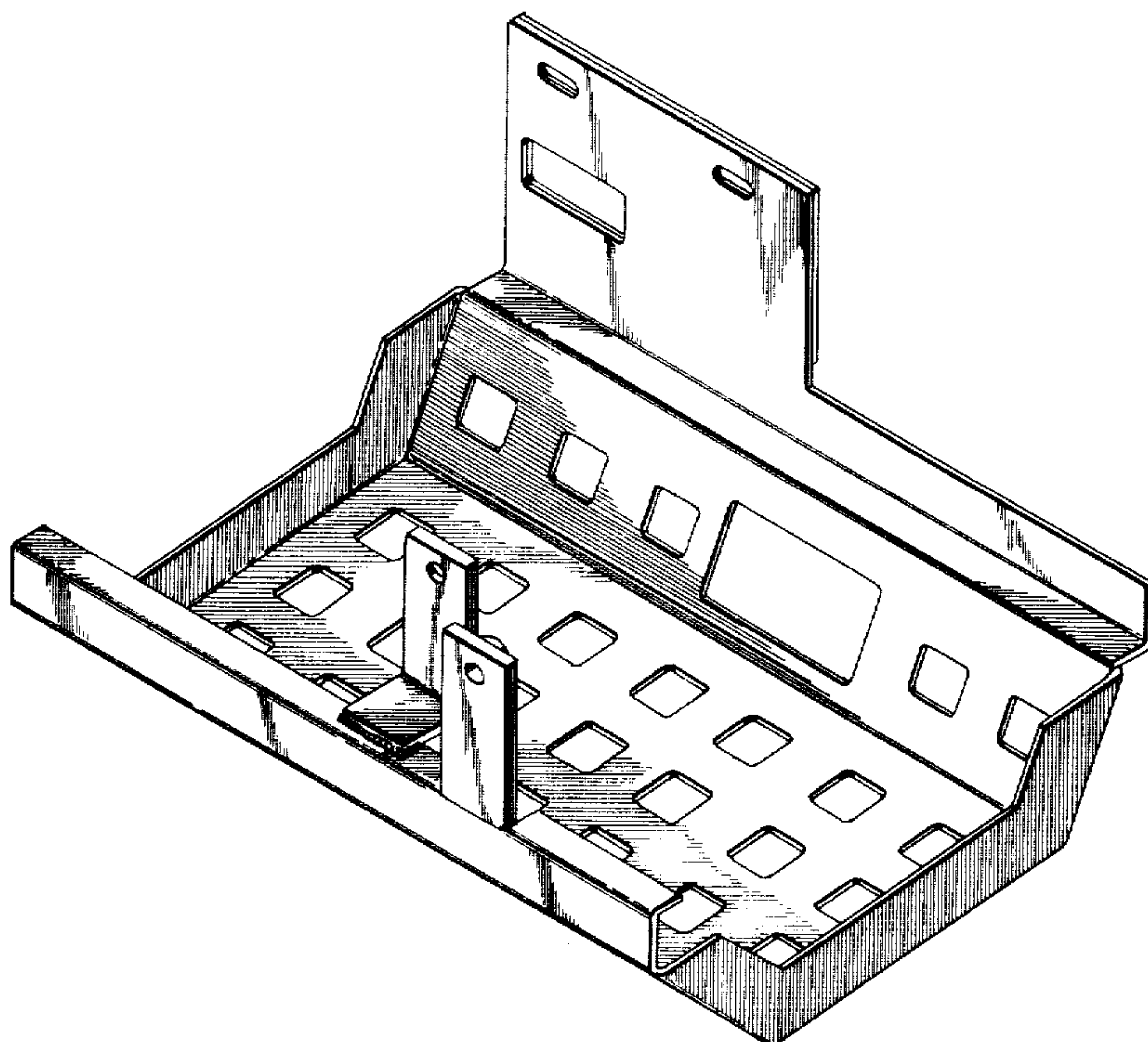

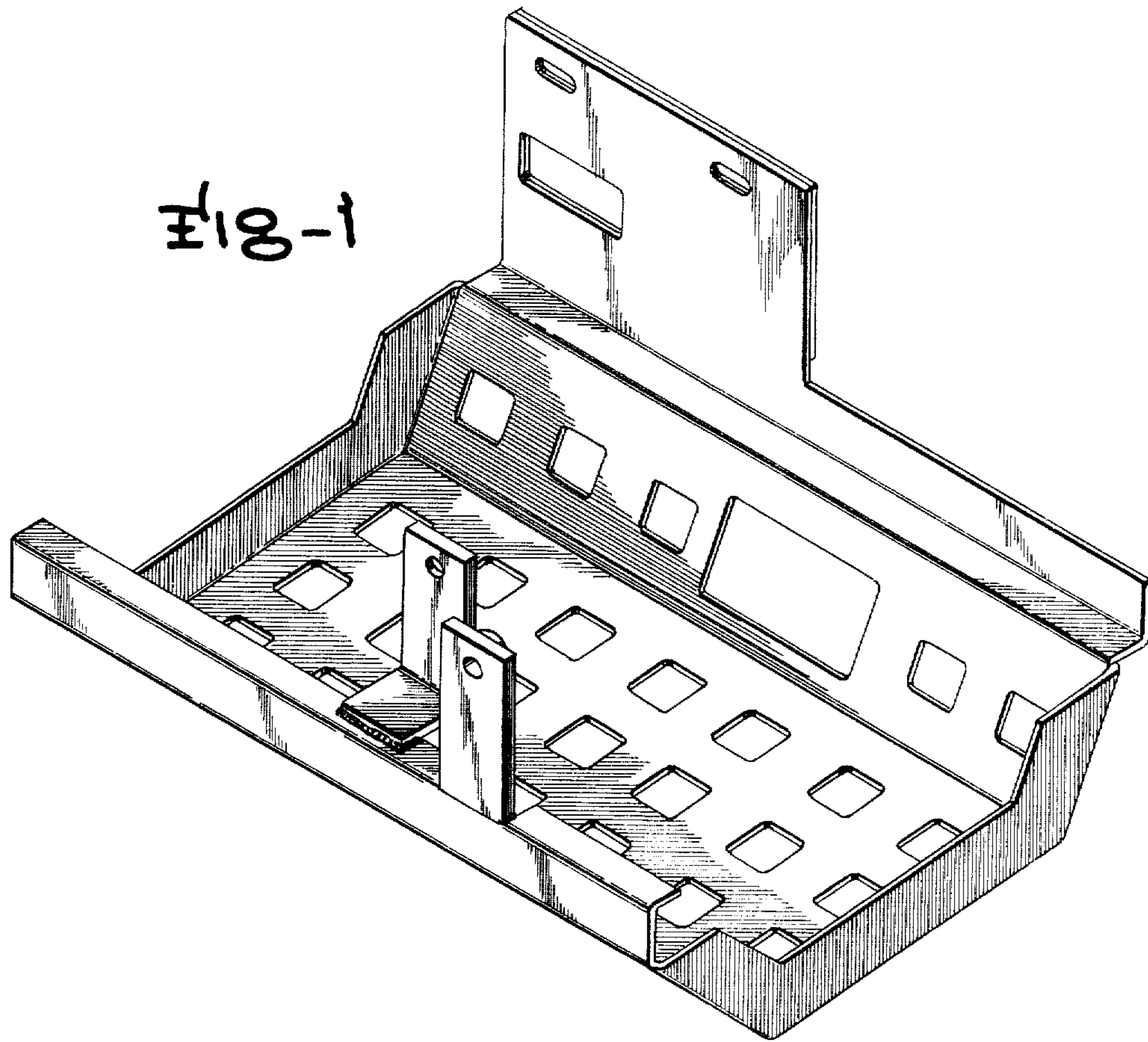

Fig-2

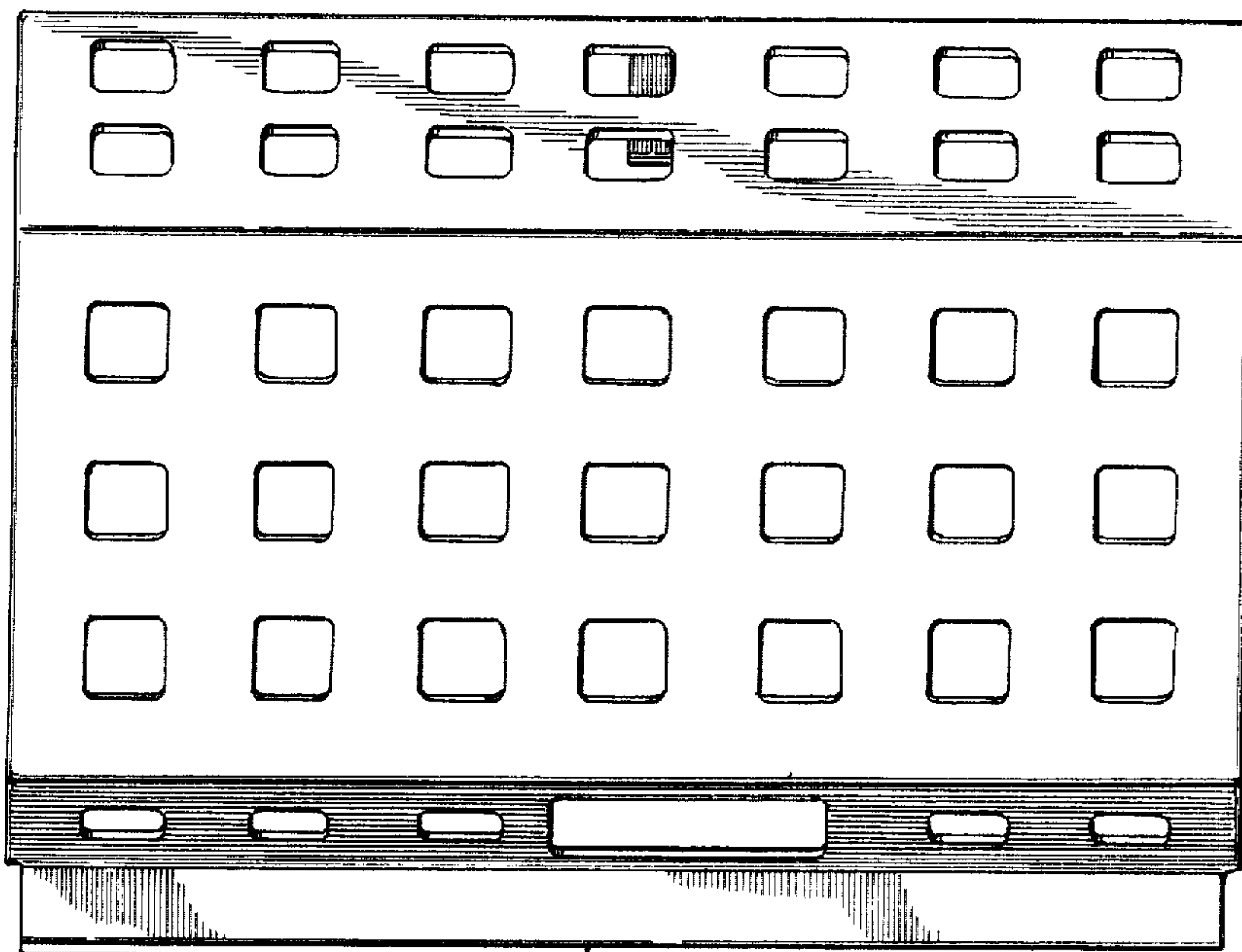

FIG-4

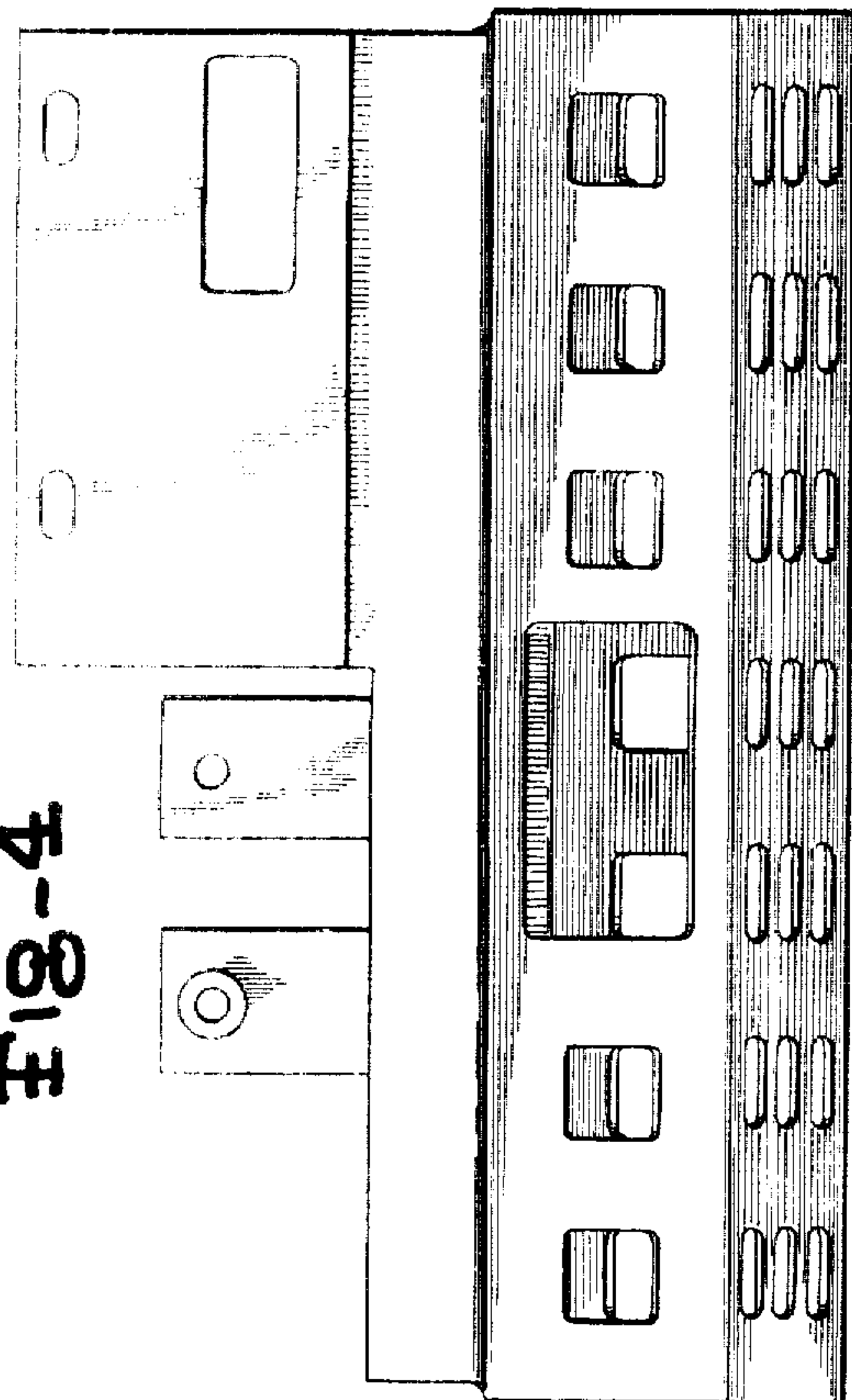

FIG-6

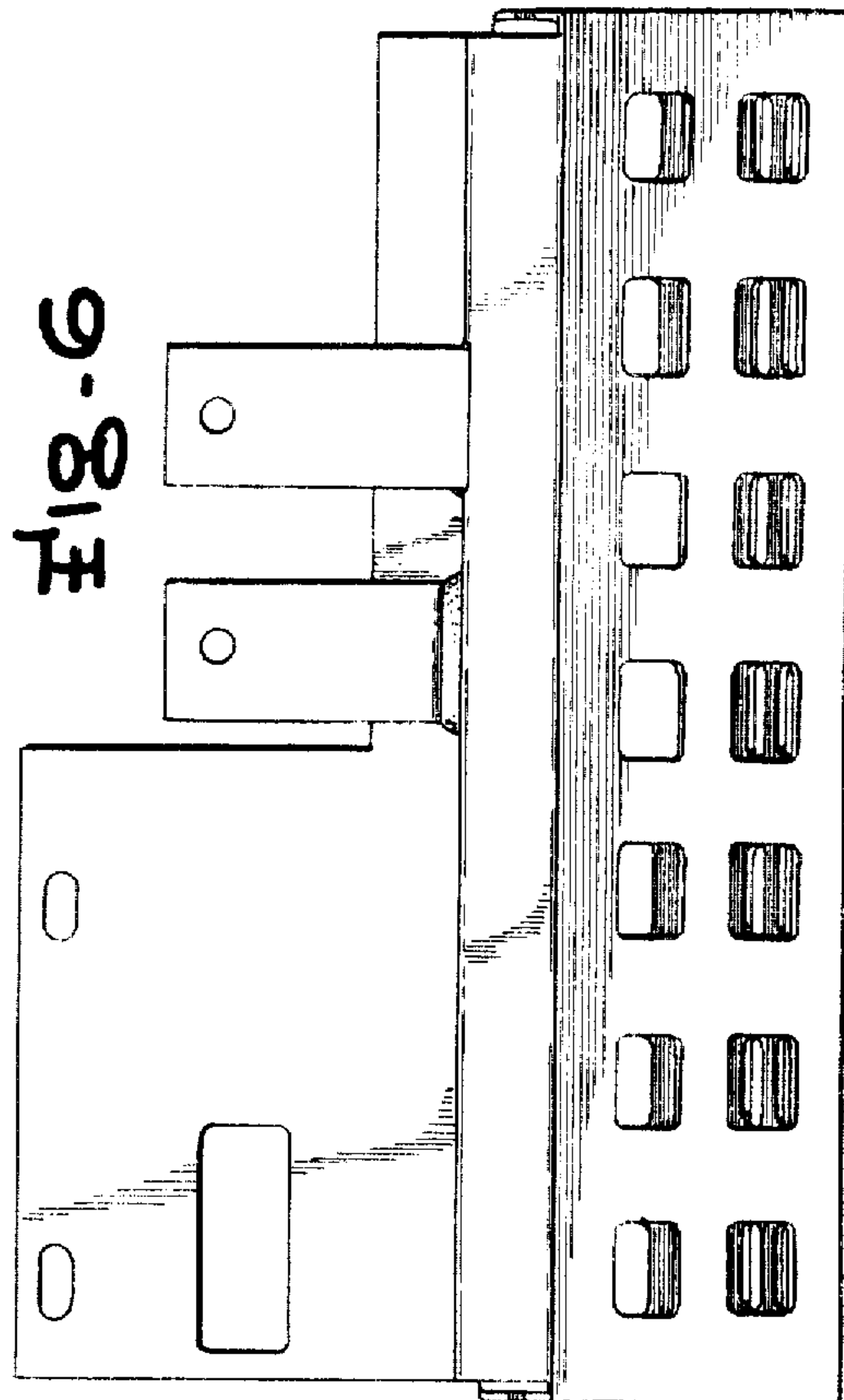

FIG-3

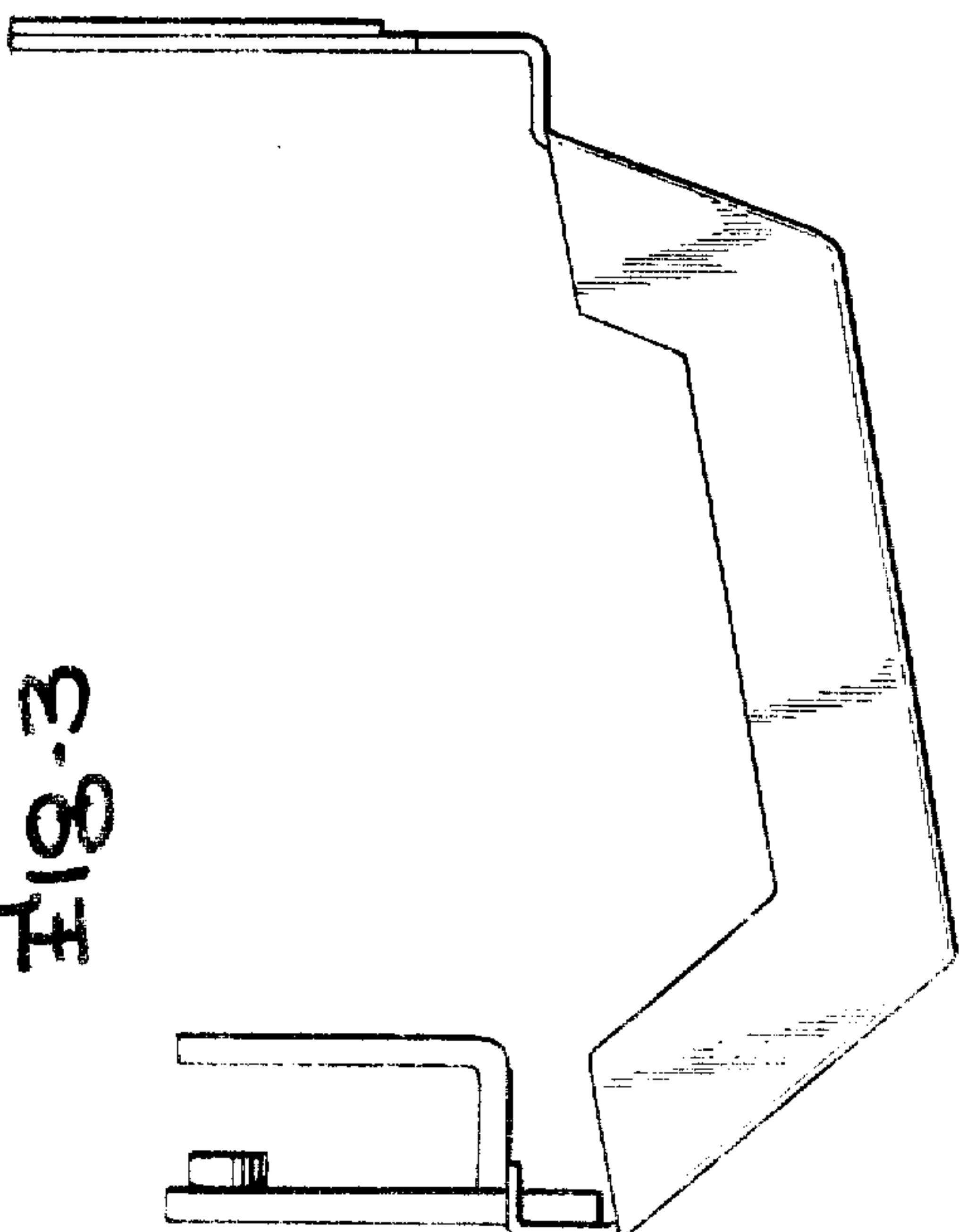

FIG-5

