

[54] TOY VEHICLE

[75] Inventor: **Kenzou Kassai**, Osaka, Japan
[73] Assignee: **Kassai Kabushikikaisha**, Osaka, Japan
[**] Term: **14 Years**
[21] Appl. No.: **29,071**
[22] Filed: **Apr. 11, 1979**

[30] **Foreign Application Priority Data**
Oct. 11, 1978 [JP] Japan 53-43286

[51] **Int. Cl.** **D21-01**
[52] **U.S. Cl.** **D21/78**
[58] **Field of Search** **D21/71, 76, 78, 79, D21/81, 134, 46/201, 202, 206, 210; 280/87.01, 1.13, 87.02 R, 87.04 R; D12/14, 82, 93**

[56] **References Cited**
U.S. PATENT DOCUMENTS
D. 113,541 2/1939 Pajeau D21/166
D. 252,829 9/1979 Nakao et al. D21/78

D. 253,710 12/1979 Nakao et al. D21/78

Primary Examiner—Charles A. Rademaker
Attorney, Agent, or Firm—Birch, Stewart, Kolasch & Birch

[57] **CLAIM**

The ornamental design for a toy vehicle, as shown and described.

DESCRIPTION

FIG. 1 is a front elevational view of the a toy vehicle showing my new design;
FIG. 2 is a rear elevational view thereof;
FIG. 3 is a bottom plan view thereof;
FIG. 4 is a top plan view thereof;
FIG. 5 is a left side elevational view thereof;
FIG. 6 is a right side elevational view thereof;
FIG. 7 is a front perspective view thereof; and
FIG. 8 is another front perspective view thereof showing the front area of the design in an alternate condition. The characteristic feature of my design resides in the ornamental facial expression member which can be changed as best shown in FIG. 8.

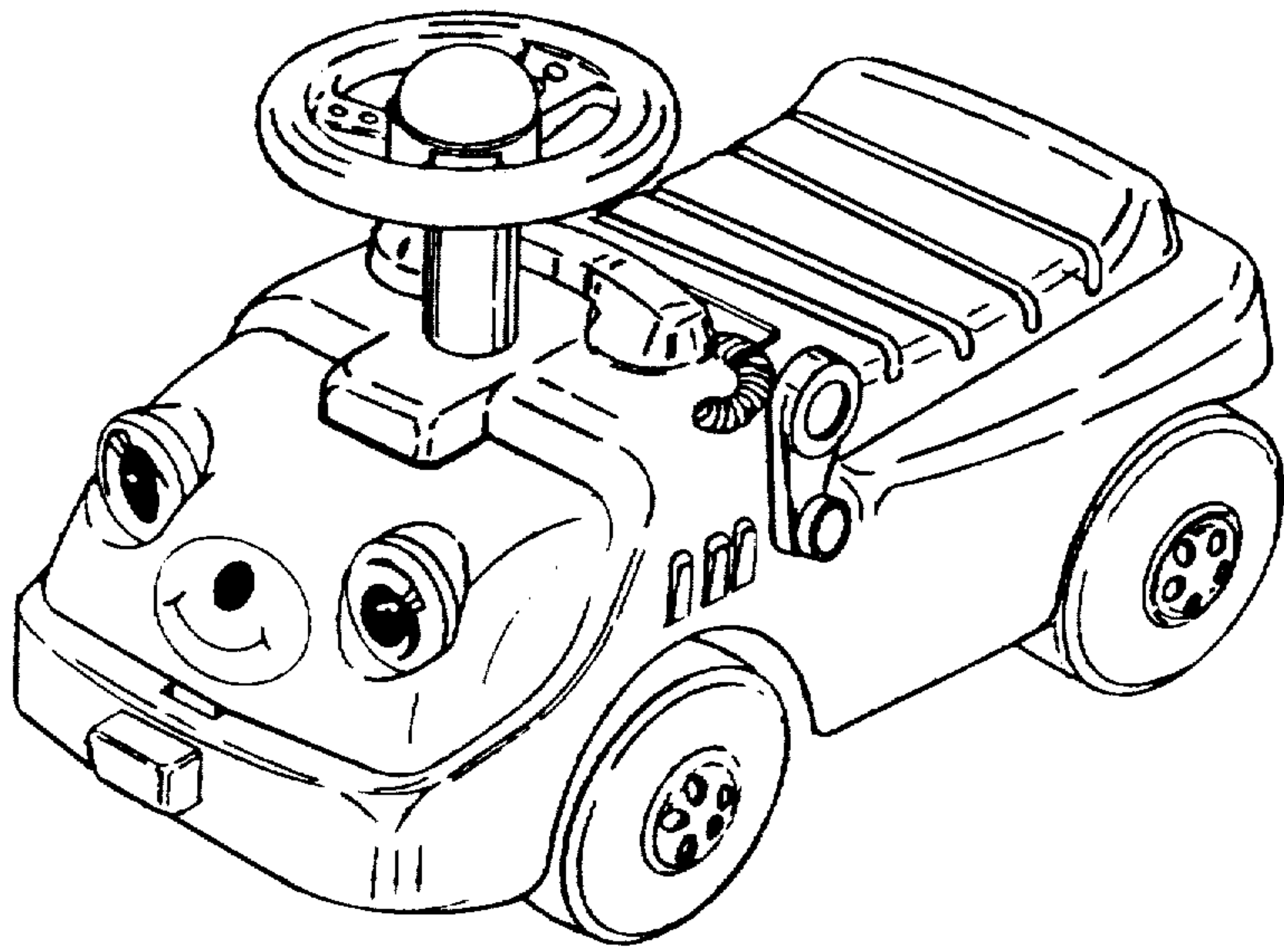

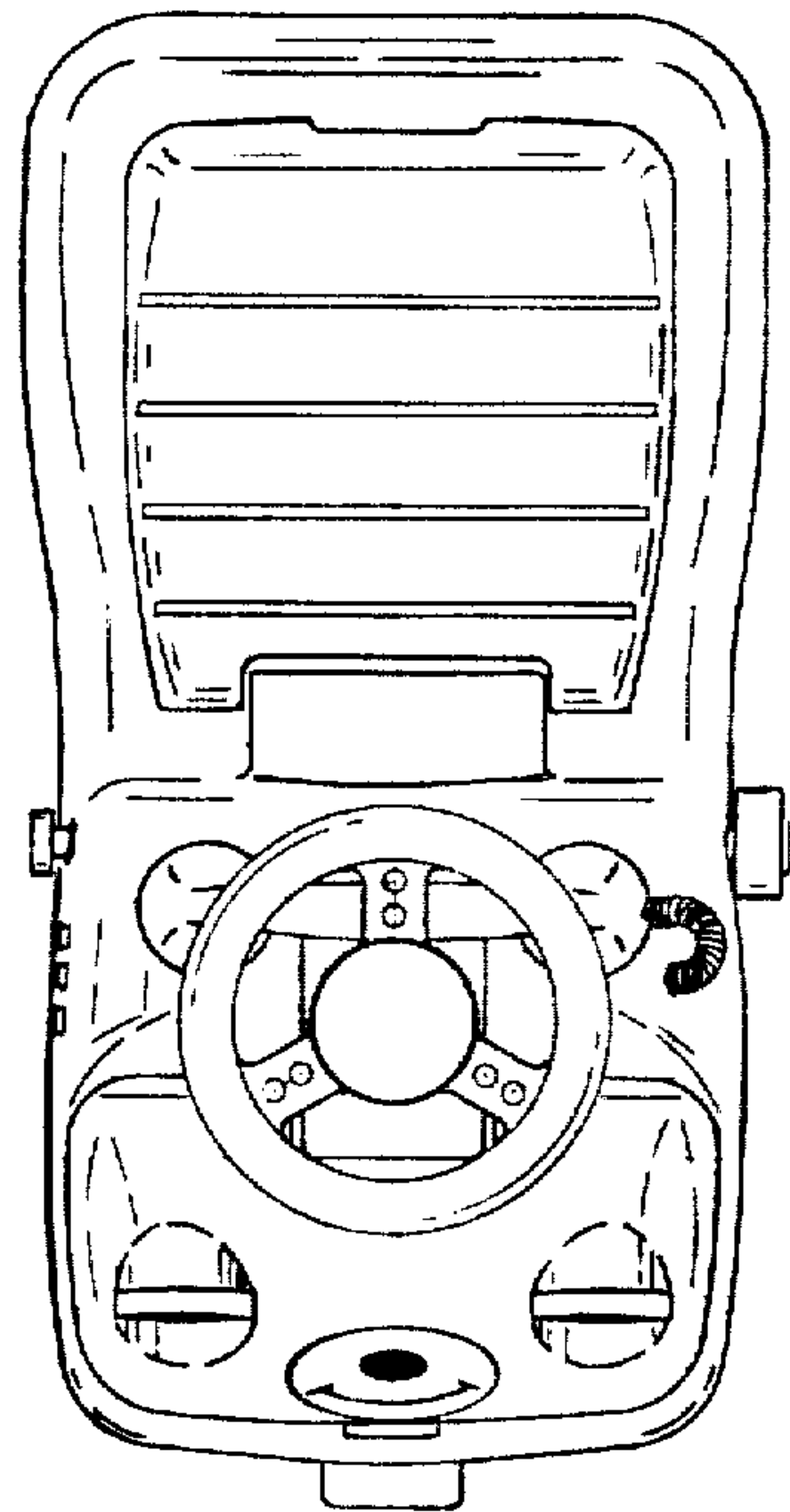

FIG. 4

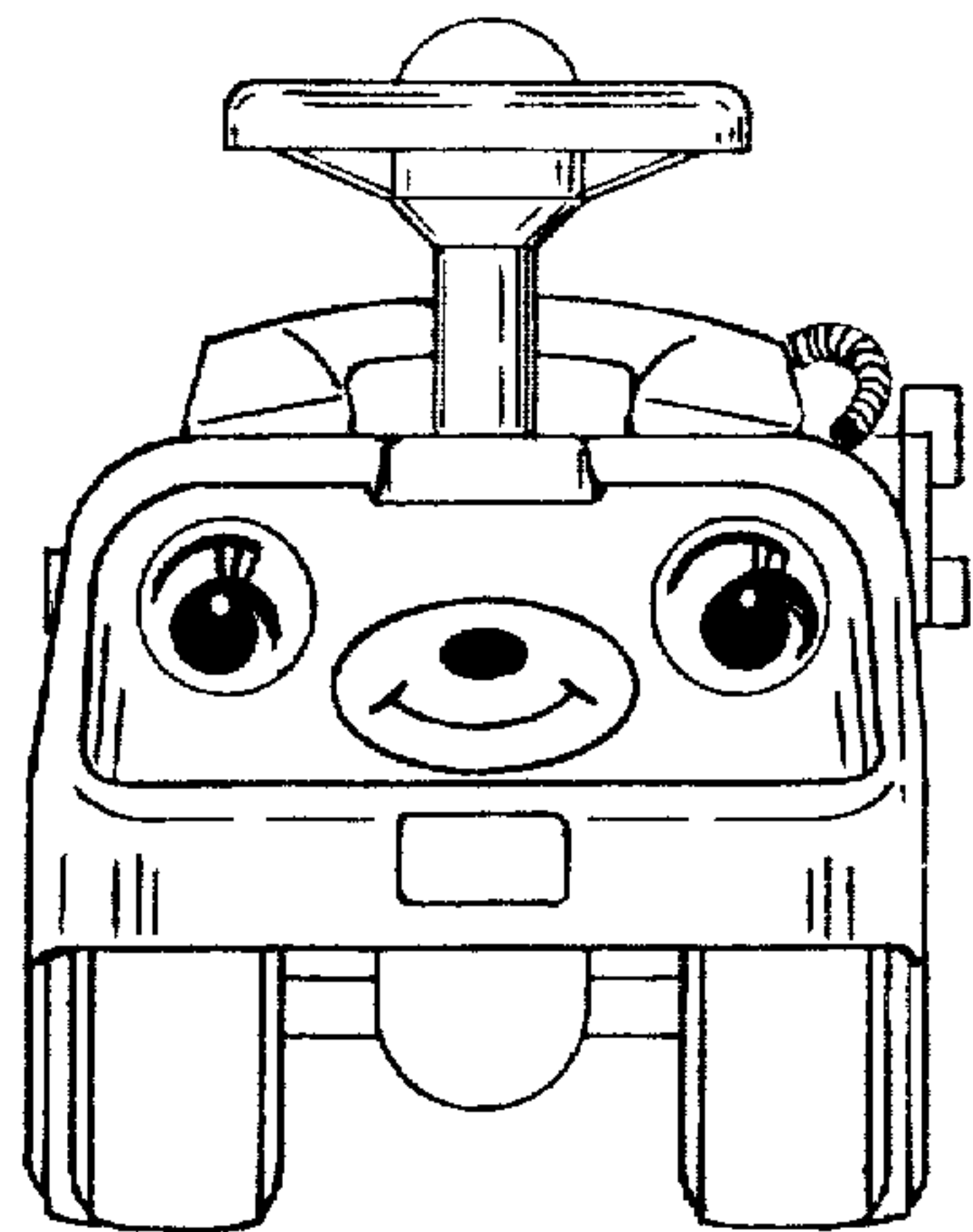

FIG. 1

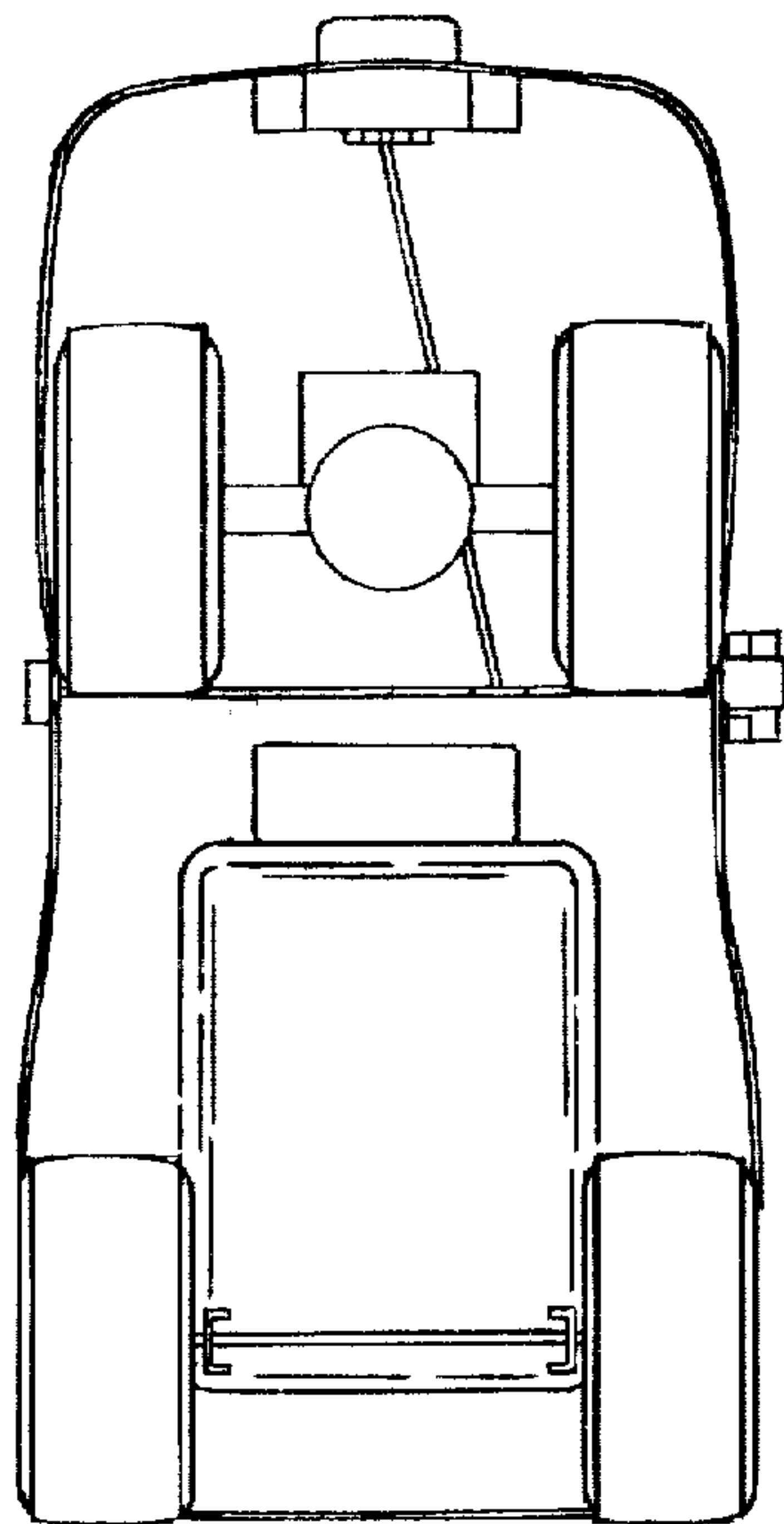

FIG. 3

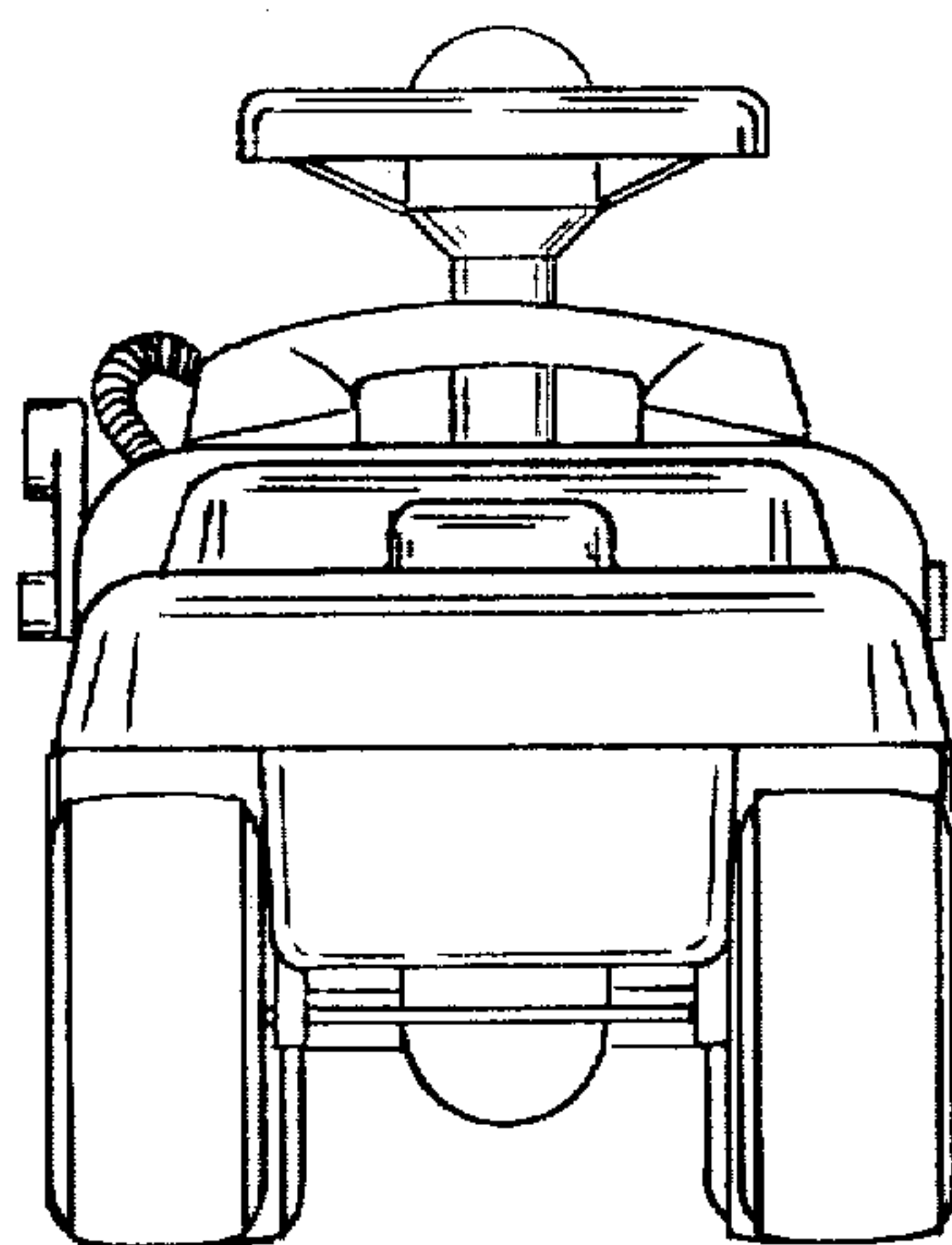

FIG. 2

FIG. 7

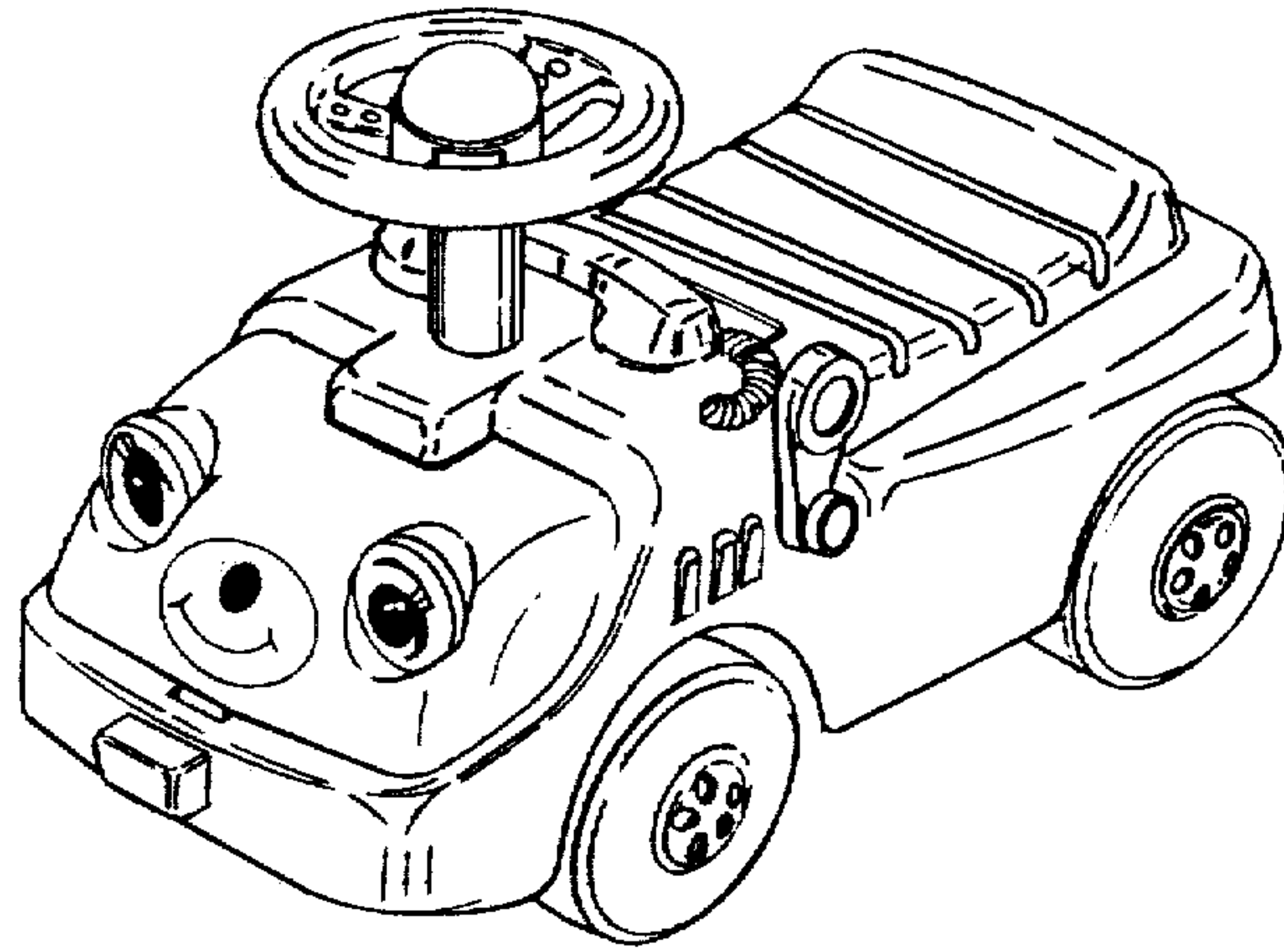

FIG. 5

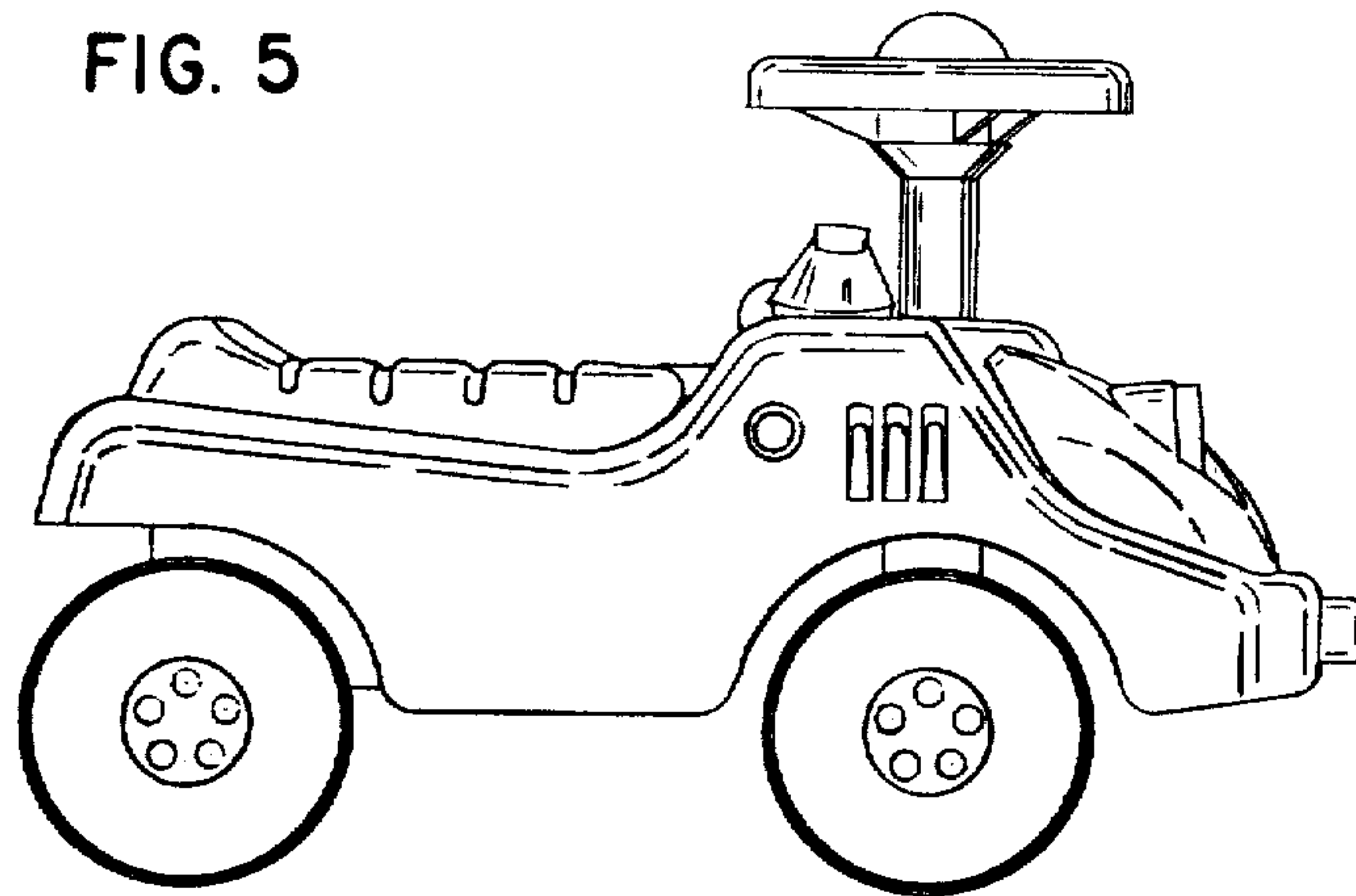

FIG. 8

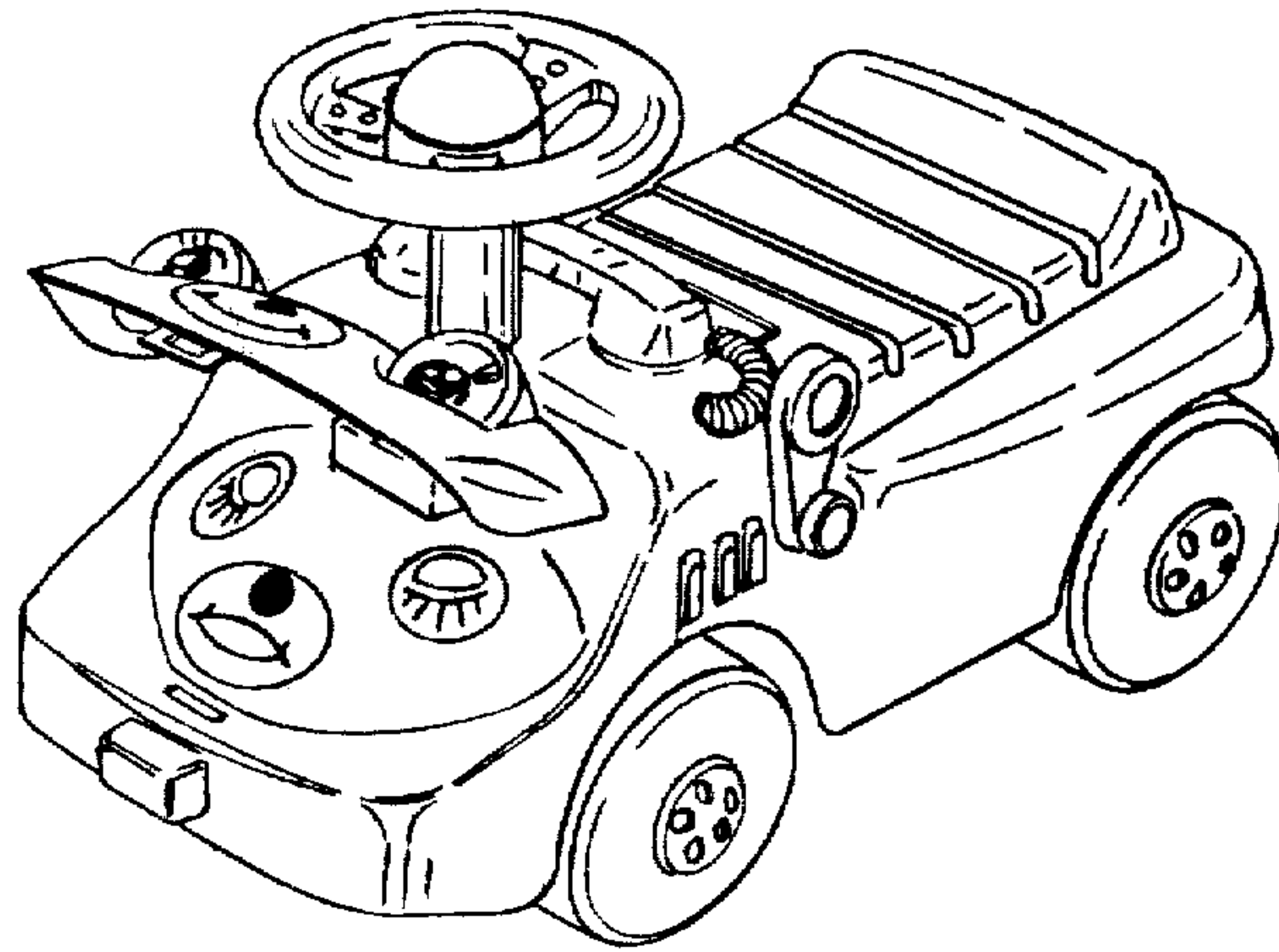

FIG. 6

