

[54] TRACTION TIRE CLAMP FOR A MOTOR VEHICLE WHEEL

[76] Inventor: Edmund A. Zielinski, R.D. 4, Box 418, Newton, N.J. 07860

[**] Term: 14 Years

[21] Appl. No.: 22,604

[22] Filed: Mar. 21, 1979

[51] Int. Cl. D12-16

[52] U.S. Cl. D12/154

[58] Field of Search D12/154; 152/218, 225 R, 152/225 C, 228

[56] References Cited

U.S. PATENT DOCUMENTS

2,867,259	1/1959	Barron	152/225 C
2,870,814	1/1959	Khachikian	152/218
2,963,064	12/1960	Rucker	152/225 R
3,063,489	11/1962	Blumkin	152/225 R
3,208,498	9/1965	Schieber et al.	152/225 R
3,283,798	11/1966	Mandato	152/228
3,827,473	8/1974	Blickensderfer et al.	152/218

FOREIGN PATENT DOCUMENTS

1814705	6/1970	Fed. Rep. of Germany	152/218
2327111	5/1977	France	152/225 R

Primary Examiner—James M. Gandy
Attorney, Agent, or Firm—Nicholas J. Garofalo

[57] CLAIM

The ornamental design for a traction tire clamp for a motor vehicle wheel, as shown and described.

DESCRIPTION

FIG. 1 is a side elevational view of a traction tire clamp for a motor vehicle wheel showing my new design it being understood that the opposite side is a mirror image thereof;
 FIG. 2 is a front elevational view thereof;
 FIG. 3 is a rear elevational view thereof;
 FIG. 4 is a top plan view thereof;
 FIG. 5 is a bottom plan view thereof;
 FIG. 6 is a sectional view thereof taken on the line 6—6 of FIG. 1; and
 FIG. 7 is a sectional view thereof taken on the line 7—7 of FIG. 1.

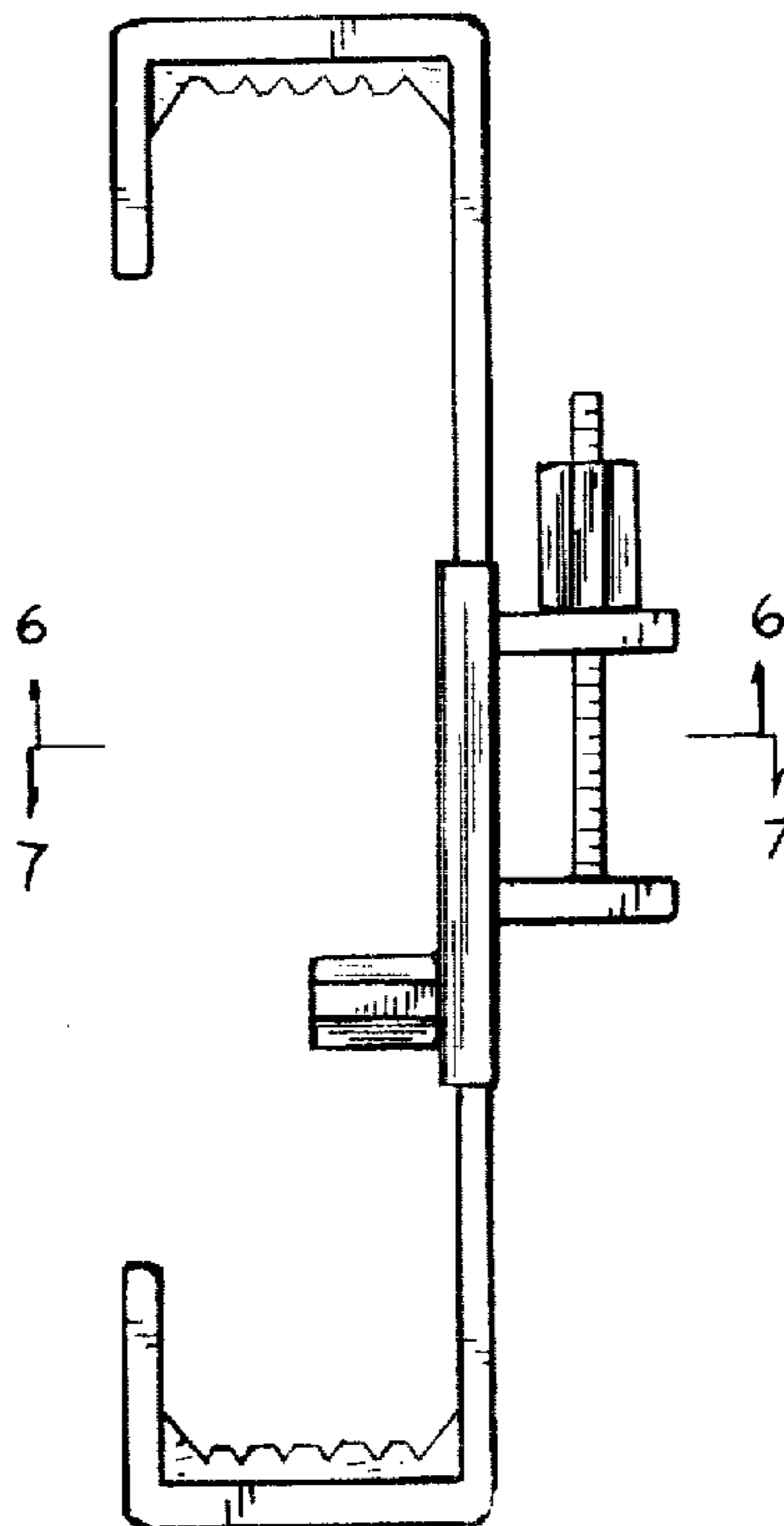

FIG. 3

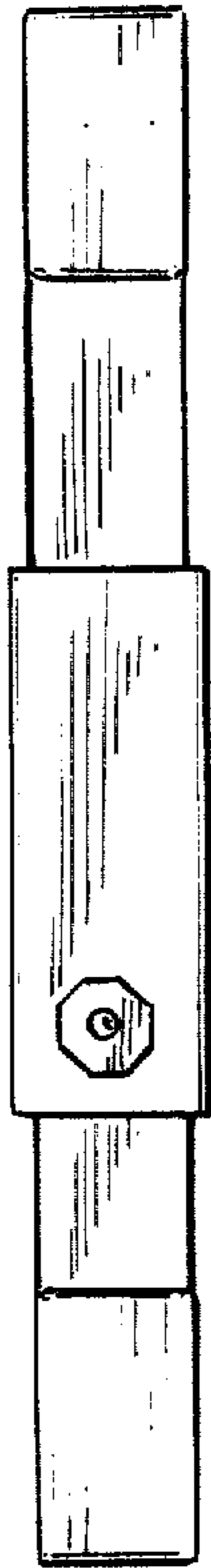

FIG. 1

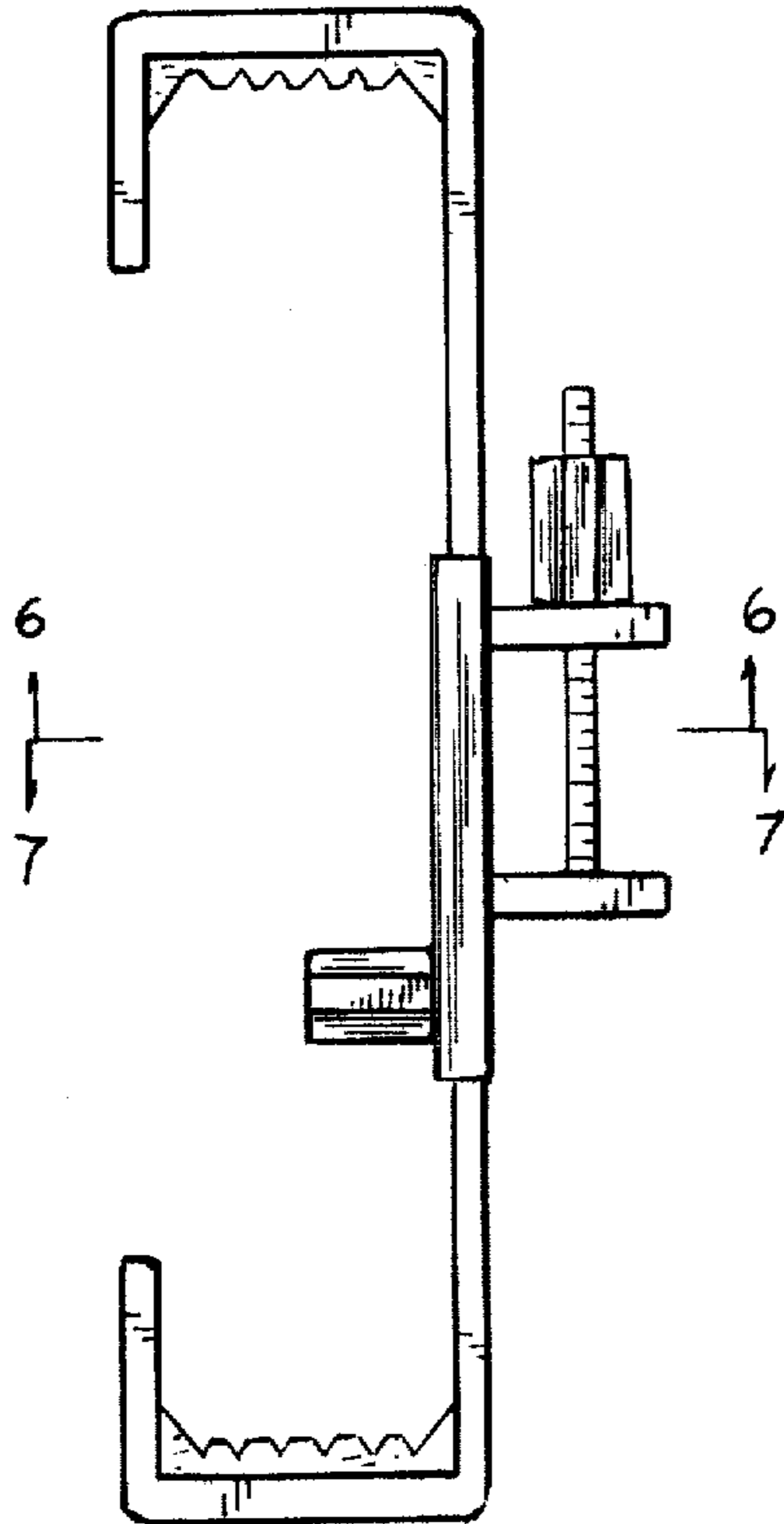

FIG. 2

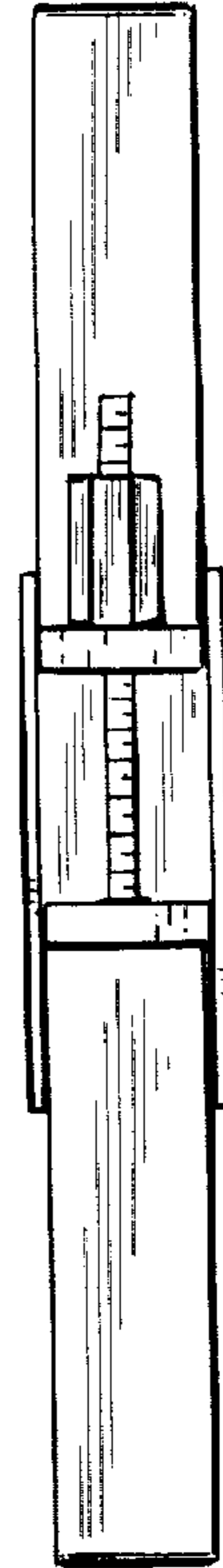

FIG. 4

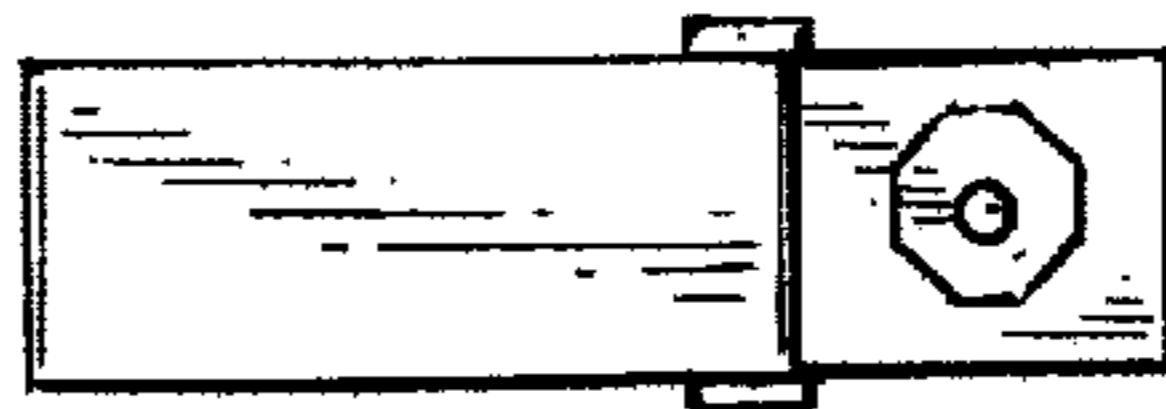

FIG. 5

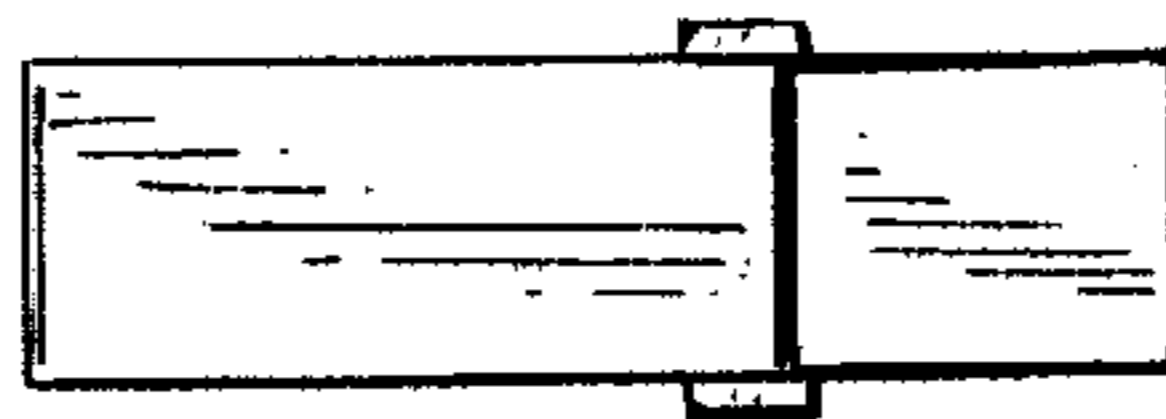

FIG. 6



FIG. 7

