

- [54] SEWING MACHINE FOOT PEDAL
- [75] Inventor: **Susumu Hanyu**, Hachioji, Japan
- [73] Assignee: **Janome Sewing Machine Co., Ltd.**,  
Tokyo, Japan
- [\*\*] Term: **14 Years**
- [21] Appl. No.: **121,251**
- [22] Filed: **Feb. 13, 1980**
- [30] **Foreign Application Priority Data**
- |                    |       |          |
|--------------------|-------|----------|
| Sep. 7, 1979 [JP]  | Japan | 54-37475 |
| Sep. 12, 1979 [JP] | Japan | 54-38020 |
- [51] Int. Cl. .... **D15-99; D13-99**
- [52] U.S. Cl. .... **D15/72; D13/36**
- [58] Field of Search ..... **D15/66, 69, 72, 78,**  
**D15/67; 74/560, 512, 561; 112/270, 277, 275,**  
**217.4; 84/1.27, 426, 229, 1.17, DIG. 7, DIG.**  
**25; 338/953; D13/36; D17/20; D24/4, 5**

- [56] **References Cited**
- U.S. PATENT DOCUMENTS**
- |           |         |                 |           |
|-----------|---------|-----------------|-----------|
| 3,353,424 | 11/1967 | Peterson et al. | 74/560    |
| 3,380,413 | 4/1968  | Kuramochi       | 112/277 X |
| 3,780,681 | 12/1973 | Sasaki          | 112/275   |
| 4,033,273 | 7/1977  | Kasuga          | 112/275 X |
- FOREIGN PATENT DOCUMENTS**
- |        |         |       |         |
|--------|---------|-------|---------|
| 475998 | 11/1952 | Italy | 338/153 |
|--------|---------|-------|---------|

*Primary Examiner*—Joel Stearman  
*Assistant Examiner*—Carmen H. Vales  
*Attorney, Agent, or Firm*—Michael J. Striker

- [57] **CLAIM**
- The ornamental design for a sewing machine foot pedal, substantially as shown and described.

**DESCRIPTION**

FIG. 1 is a perspective view of a sewing machine foot pedal showing my new design;  
FIG. 2 is a right side elevational view thereof;  
FIG. 3 is a left side elevational view thereof;  
FIG. 4 is a rear elevational view thereof;  
FIG. 5 is a front elevational view thereof;  
FIG. 6 is a top-plan view thereof; and  
FIG. 7 is a bottom-plan view thereof.

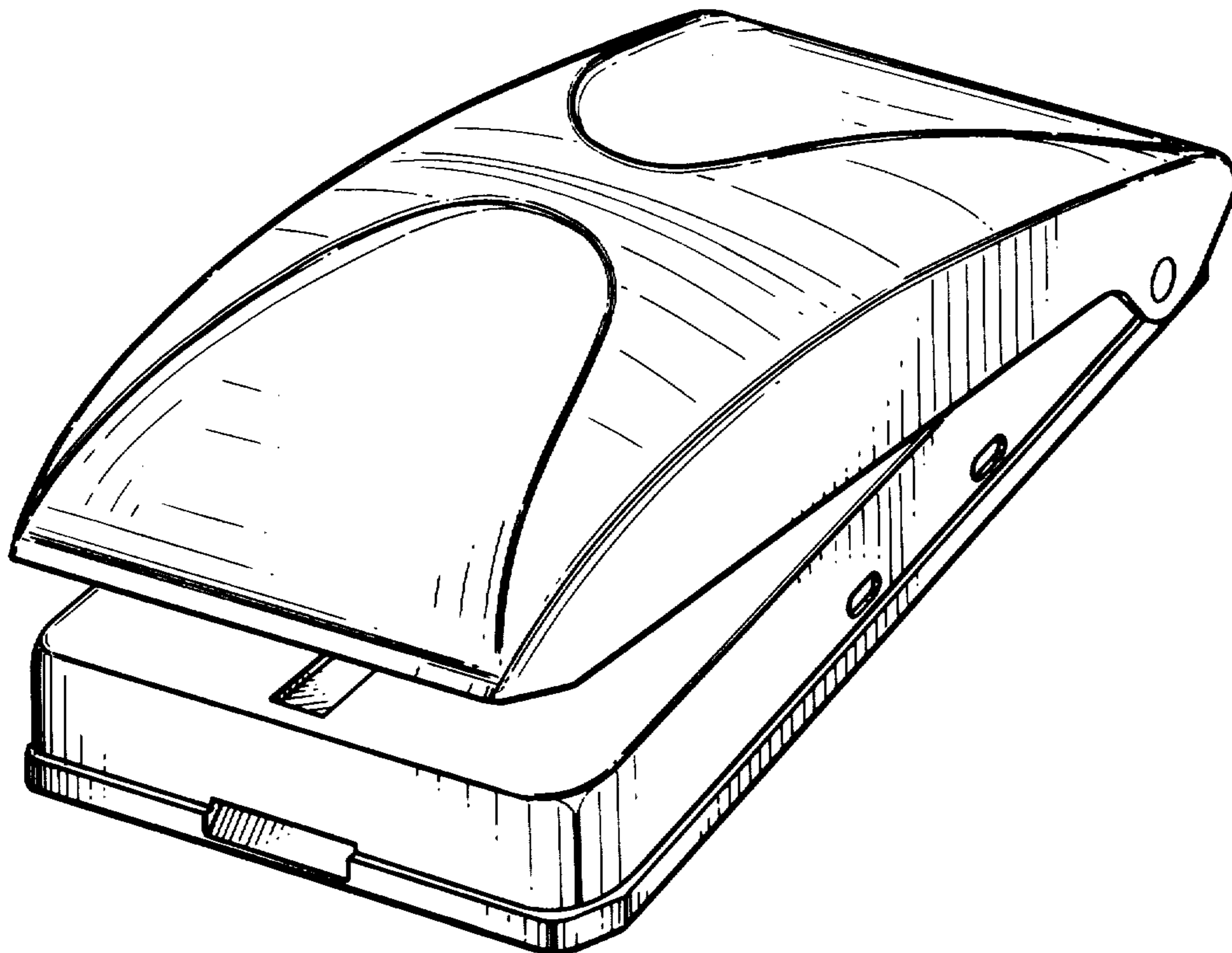

FIG. 1

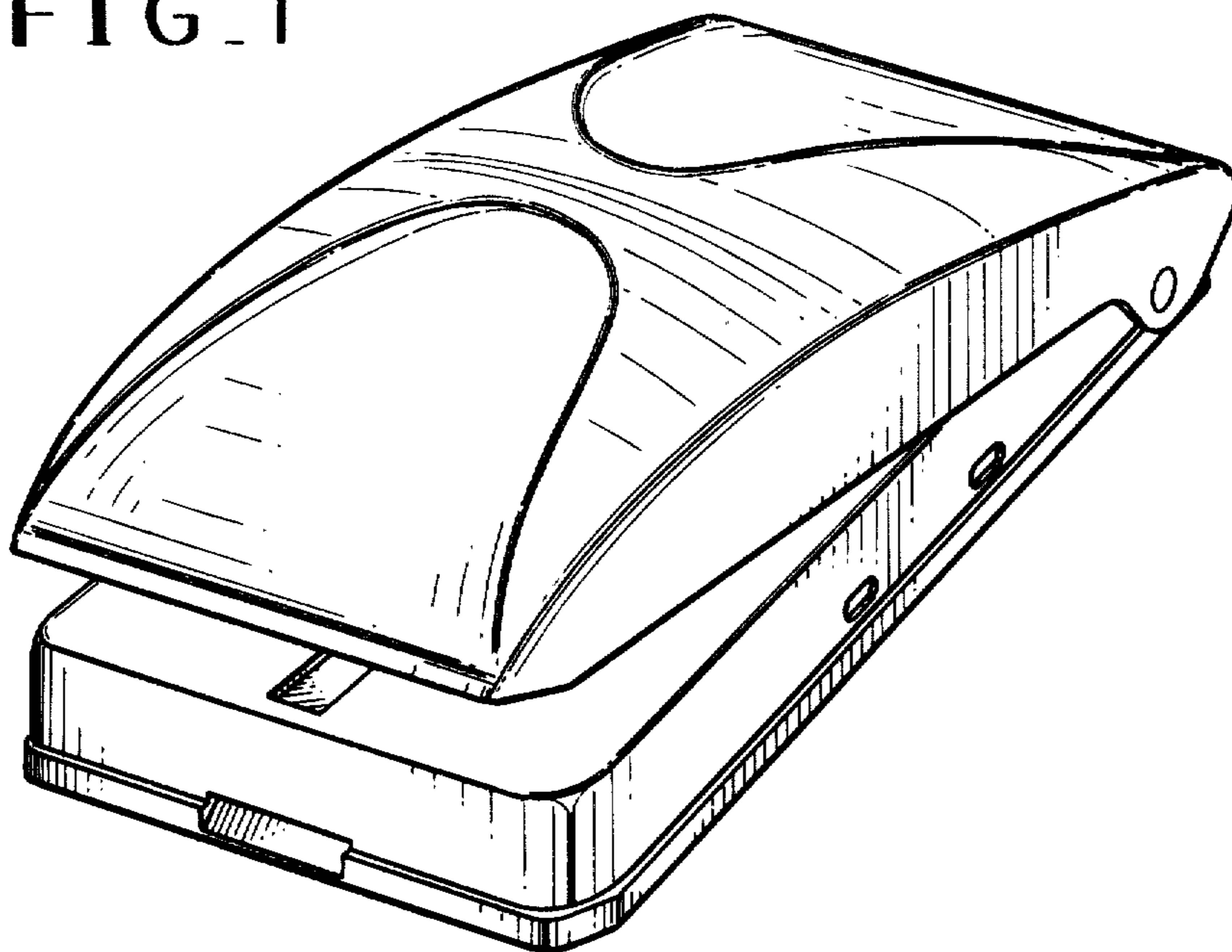

FIG. 2

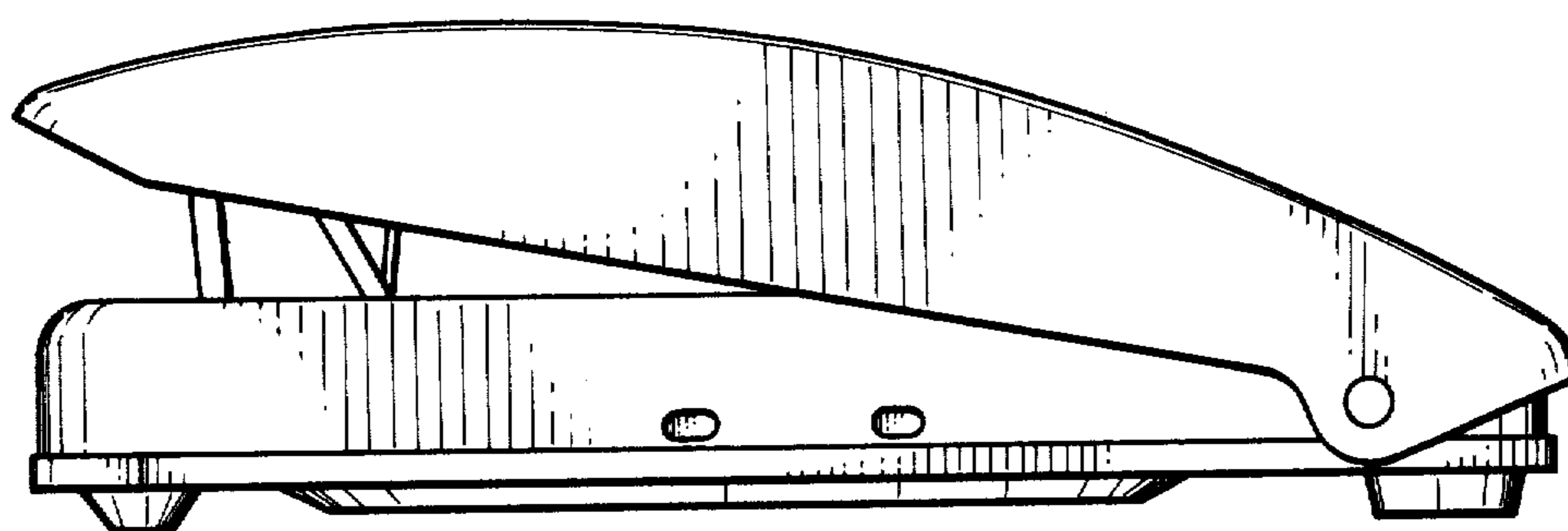

FIG. 3

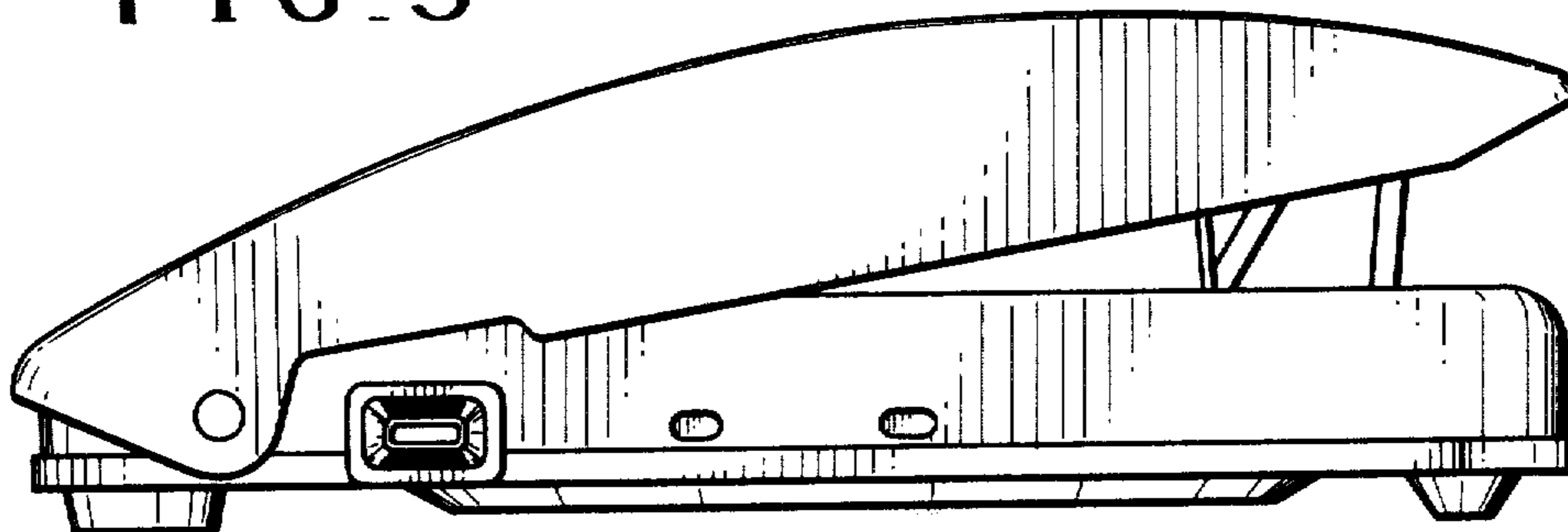

FIG. 4

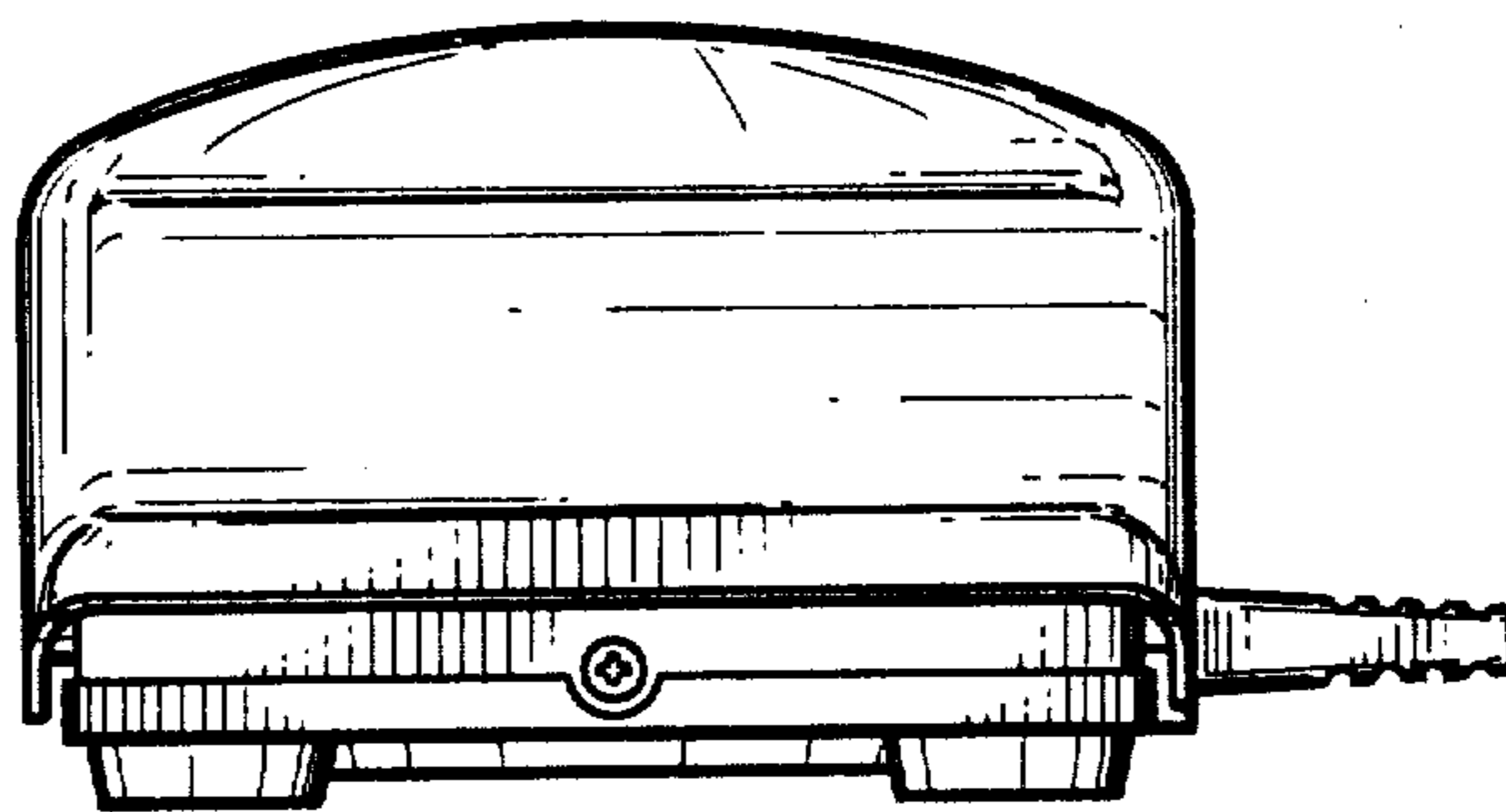

FIG. 5

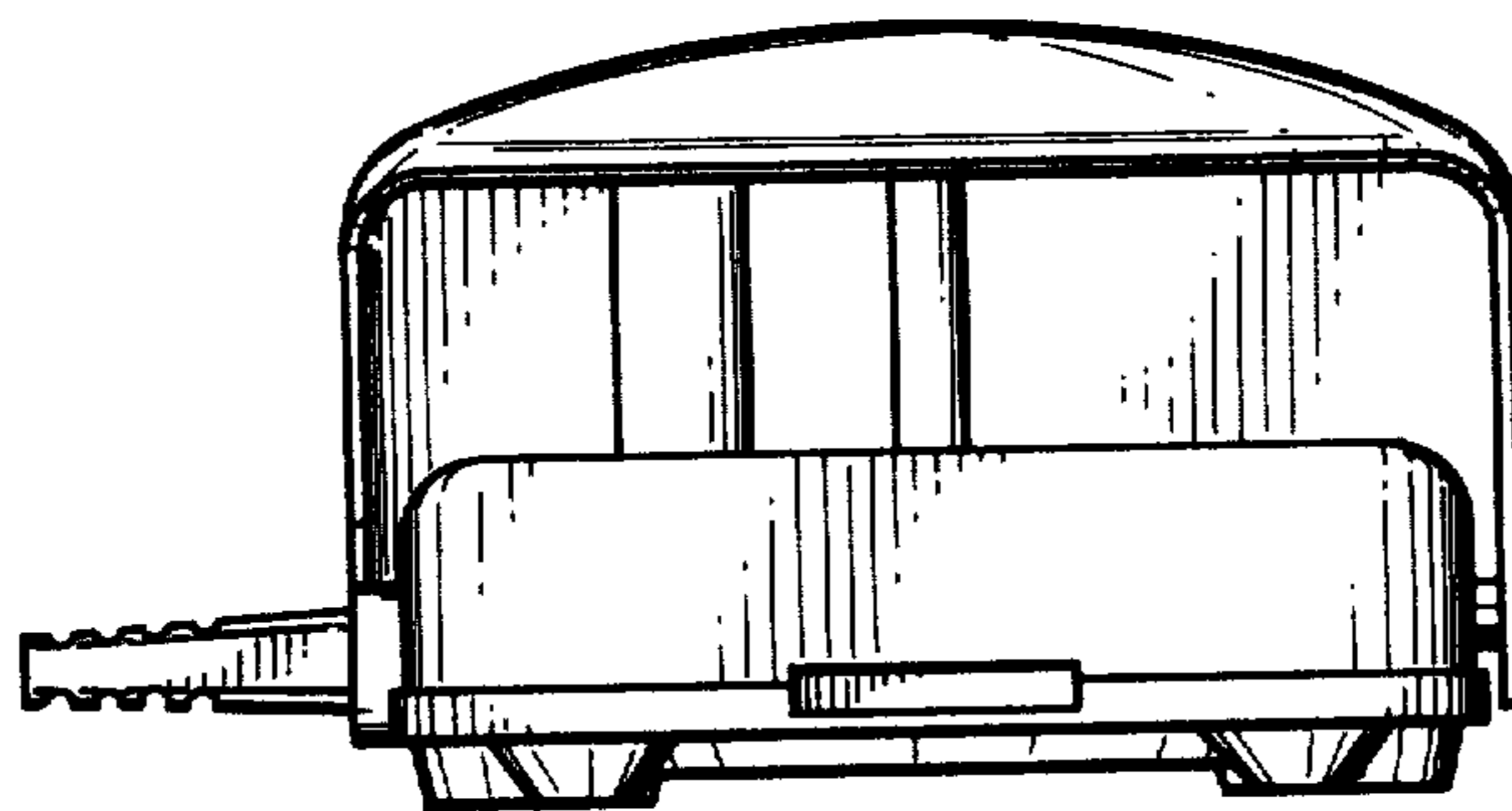

FIG. 6

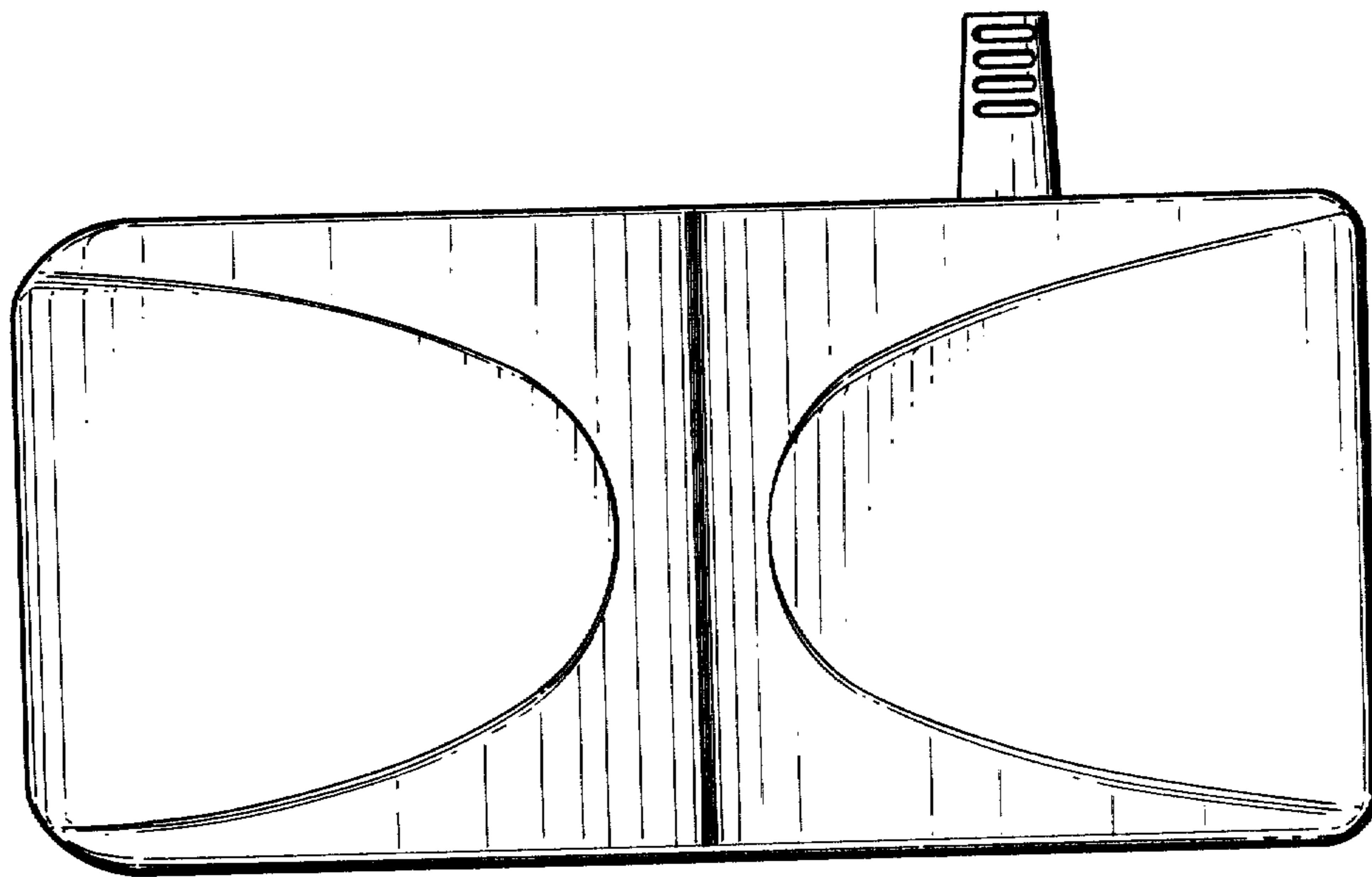

FIG. 7

