

[54] AIRCRAFT

[76] Inventor: Peter Dornier, Schachenerstrasse 97, Lindau, Fed. Rep. of Germany, 8990

[*] Notice: The portion of the term of this patent subsequent to Jun. 10, 1994, has been disclaimed.

[**] Term: 14 Years

[21] Appl. No.: 849,485

[22] Filed: Nov. 7, 1977

[51] Int. Cl. D12-07

[52] U.S. Cl. D12/324

[58] Field of Search D12/75, 78, 71, 324, D12/337, 340, 342; 244/45 R

[56] References Cited

U.S. PATENT DOCUMENTS

- D. 188,707 8/1960 Doak et al. D8/71 X
- D. 255,341 6/1980 Dornier D8/75

Primary Examiner—Alan P. Douglas
Attorney, Agent, or Firm—James E. Bryan

[57] CLAIM

The ornamental design for an aircraft, substantially as shown and described.

DESCRIPTION

FIG. 1 is a side view in elevation showing my aircraft, FIG. 2 is a top plan view of my new aircraft, FIG. 3 is a front view of my new aircraft, FIG. 4 is a perspective view of my new aircraft, FIG. 5 is a bottom view of my new aircraft, and FIG. 6 is a rear view of my new aircraft.

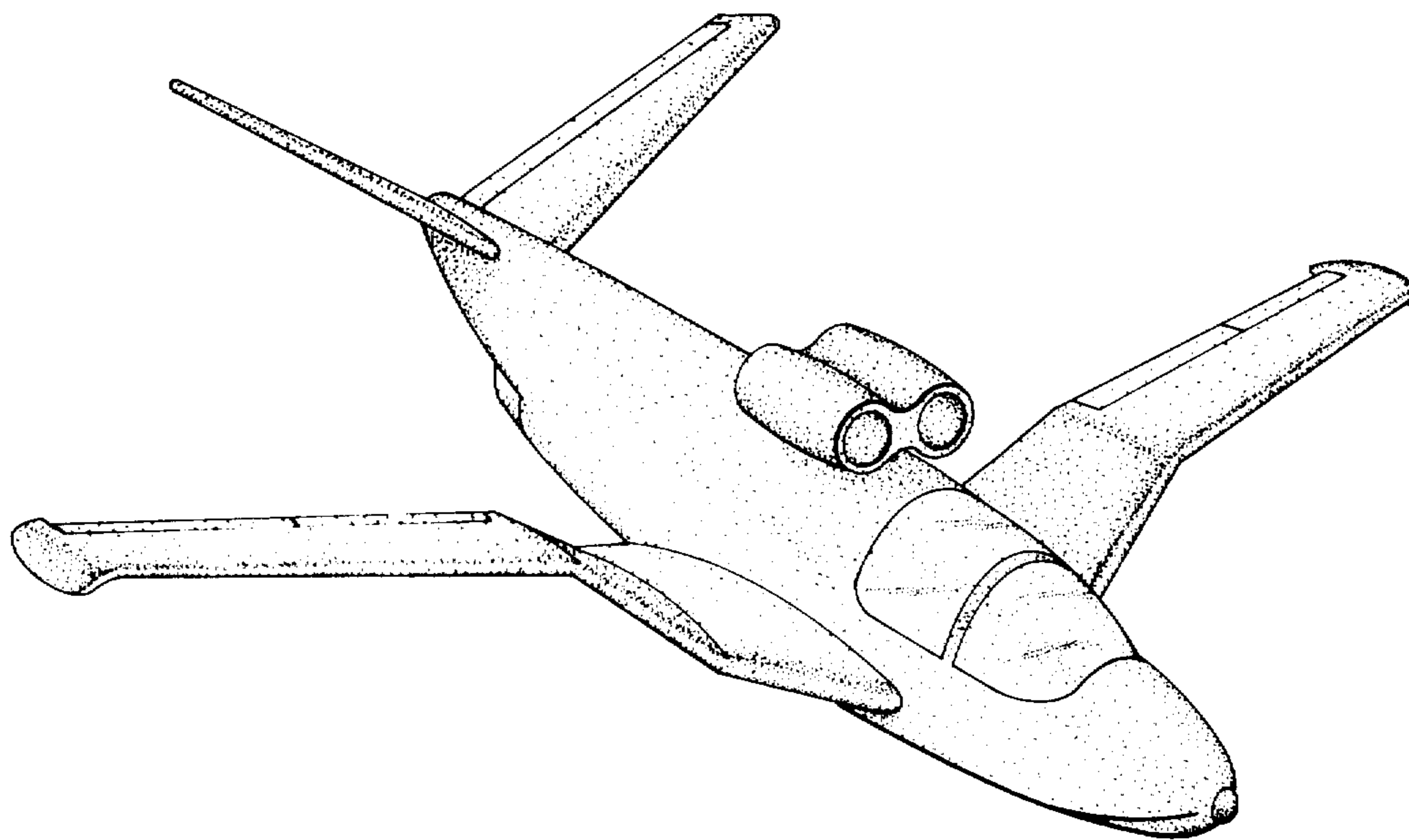

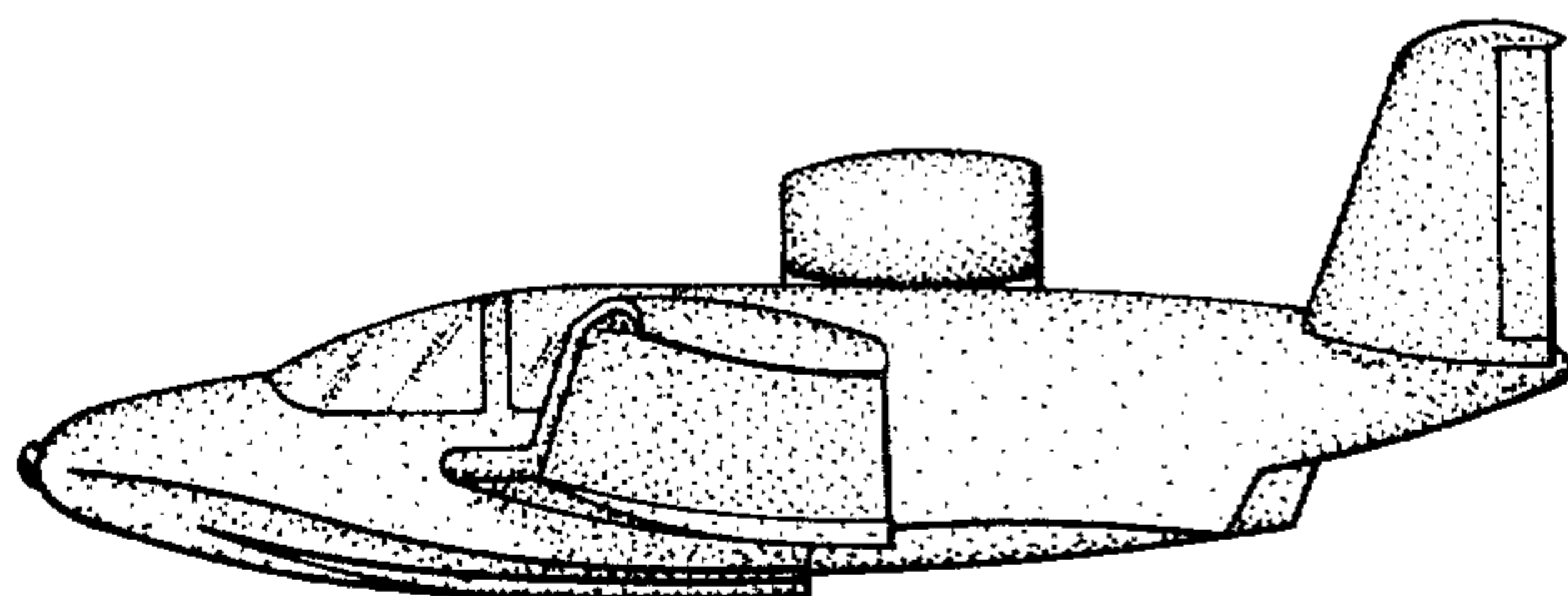

FIG. 1

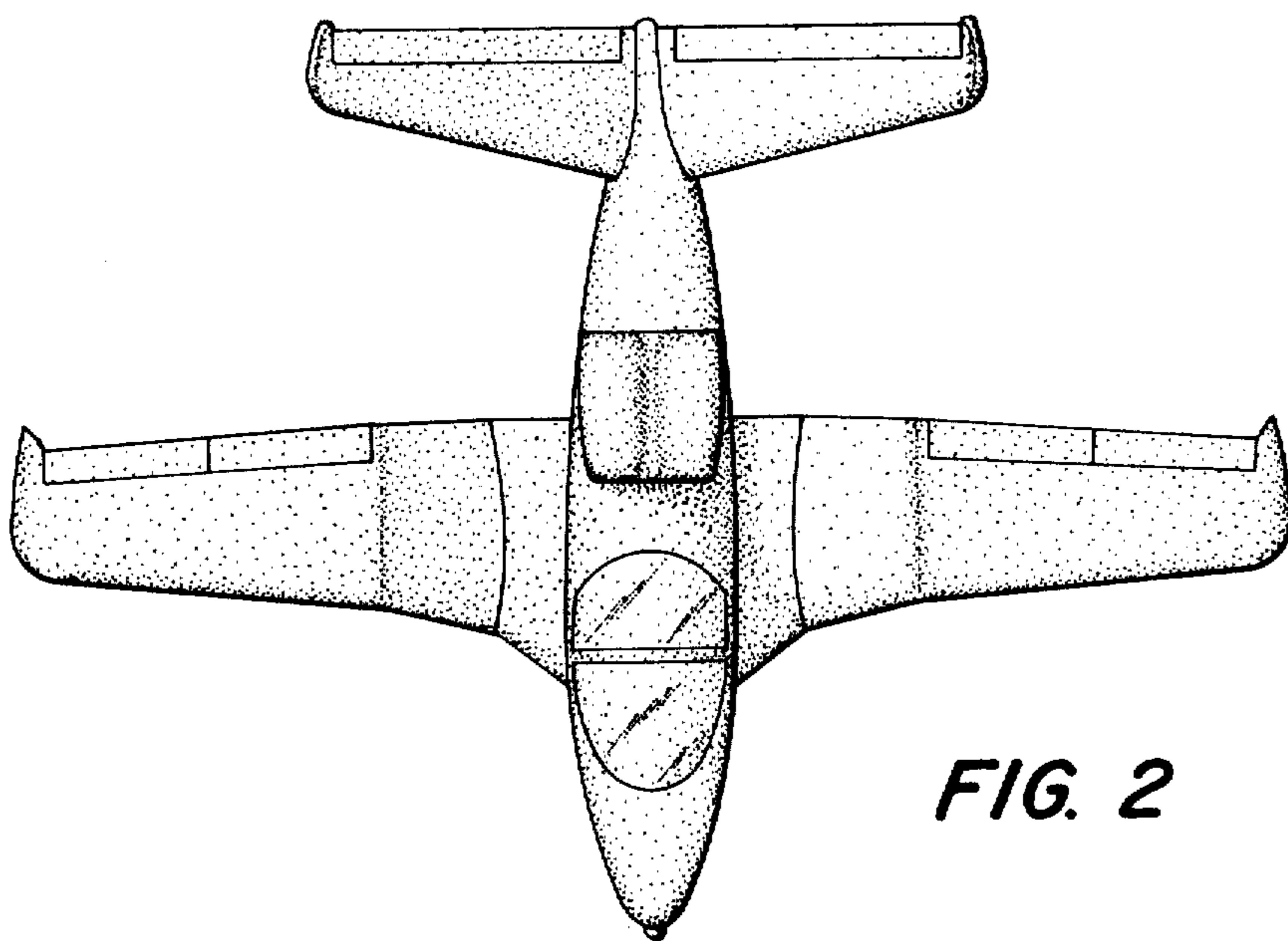

FIG. 2

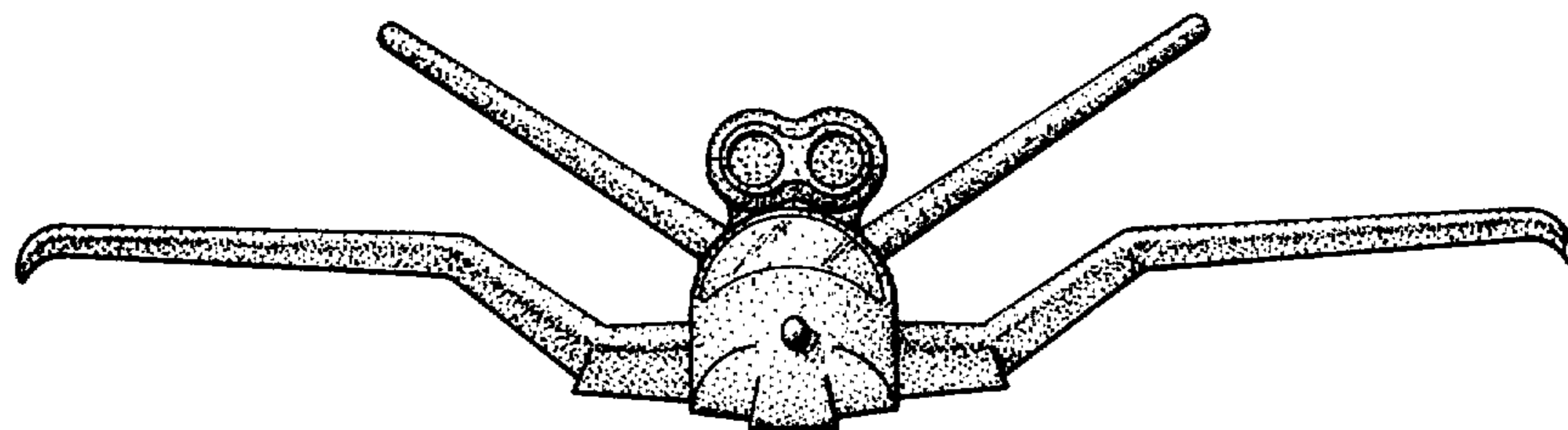

FIG. 3

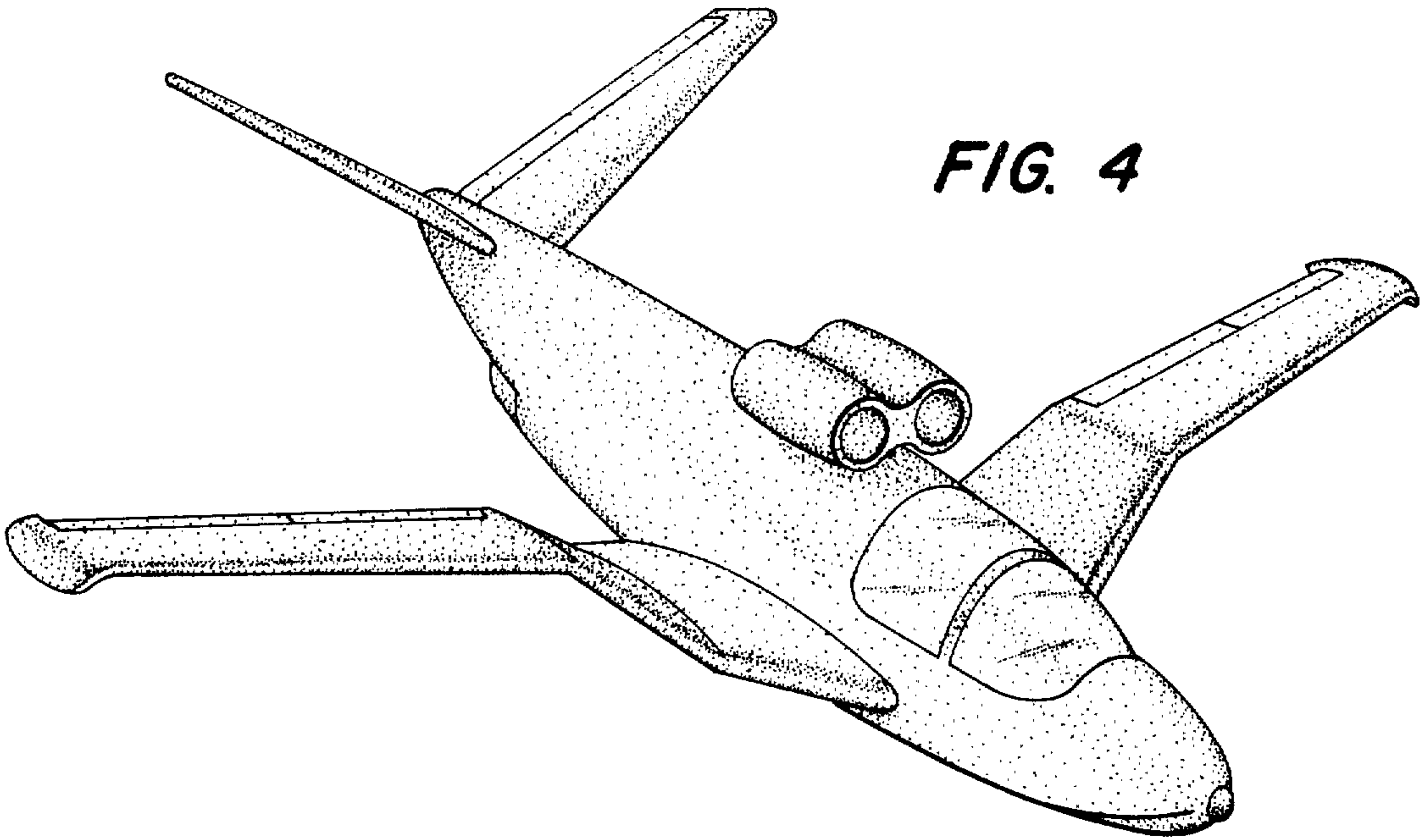

FIG. 4

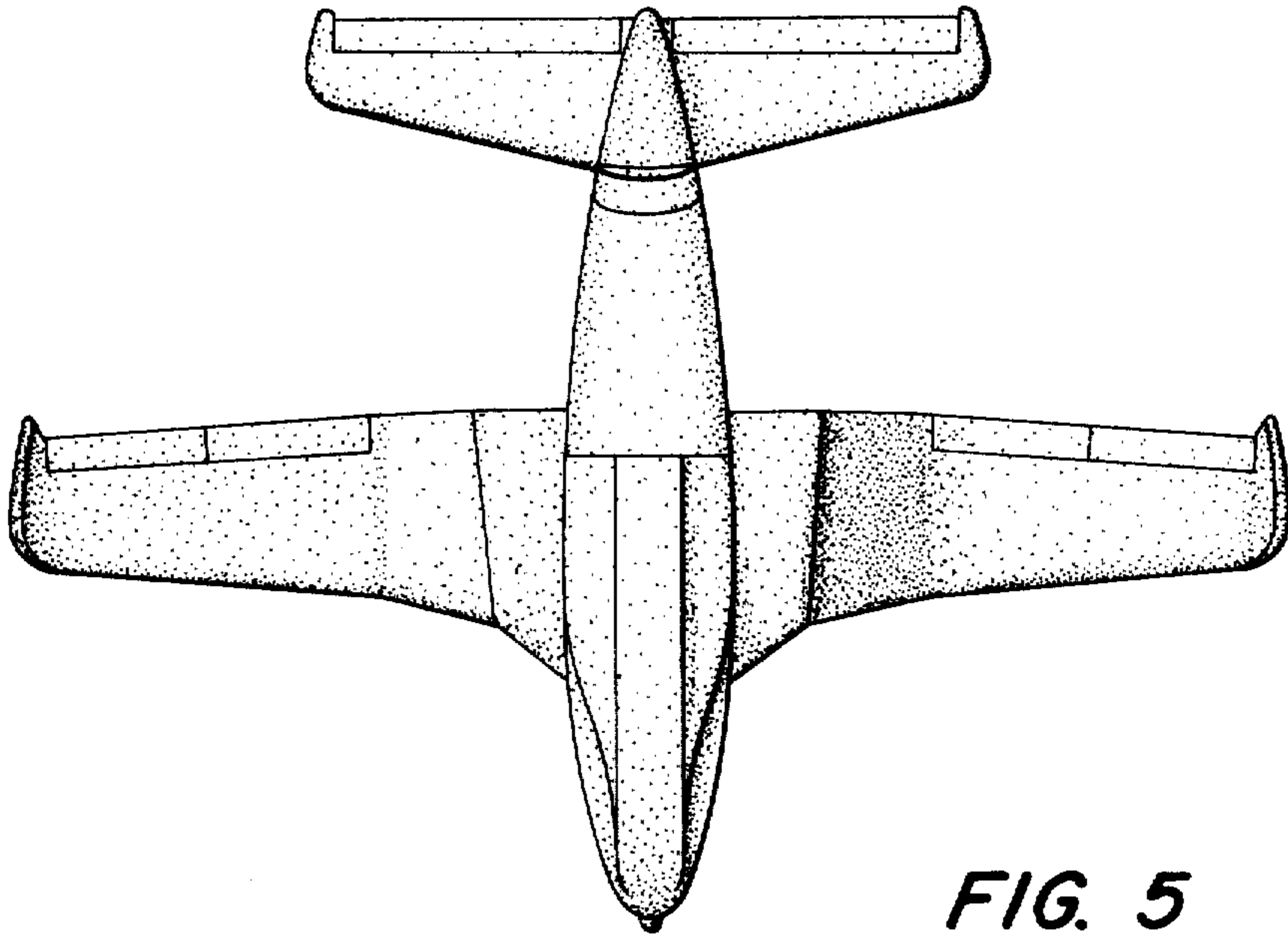

FIG. 5

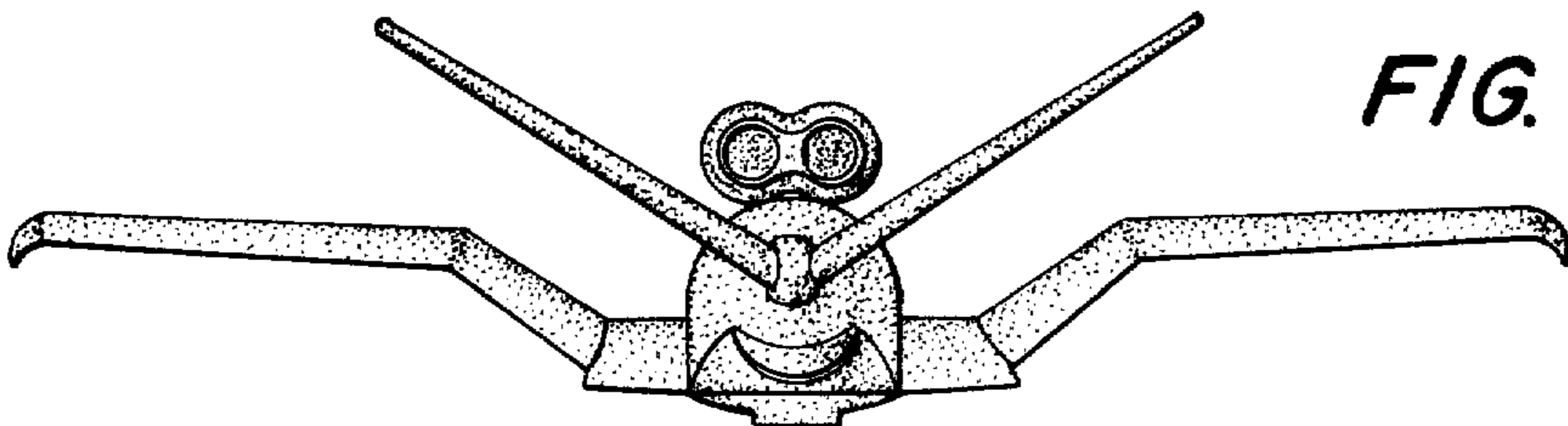

FIG. 6