

[54] **TRANSMISSION FOR BOATS**

[75] Inventors: **Kjell Borgersen, Hjalteby; Lennart Brandt, Fjäras, both of Sweden**

[73] Assignee: **AB Volvo Penta, Gothenburg, Sweden**

[**] Term: **14 Years**

[21] Appl. No.: **105,242**

[22] Filed: **Dec. 19, 1979**

[51] Int. Cl. **D15-99**

[52] U.S. Cl. **D15/149**

[58] Field of Search **D15/149; 74/606 R**

2,791,912 5/1957 Bixby 74/606

3,001,409 9/1961 Fumetti 74/606

3,054,306 9/1962 Garnier 74/606

3,186,374 6/1965 Heidner 74/606

3,463,029 8/1969 Chow 74/606

Primary Examiner—Peter M. Caun
Attorney, Agent, or Firm—Young & Thompson

[57] **CLAIM**

The ornamental design for a transmission for boats, as shown.

DESCRIPTION

FIG. 1 is a perspective view of a transmission for boats, showing our new design;
 FIG. 2 is an elevational view of the side thereof visible in FIG. 1; and
 FIG. 3 is a perspective view thereof from the side opposite that shown in FIG. 1.

[56] **References Cited**
U.S. PATENT DOCUMENTS
 2,681,029 6/1954 Canazzi 74/606

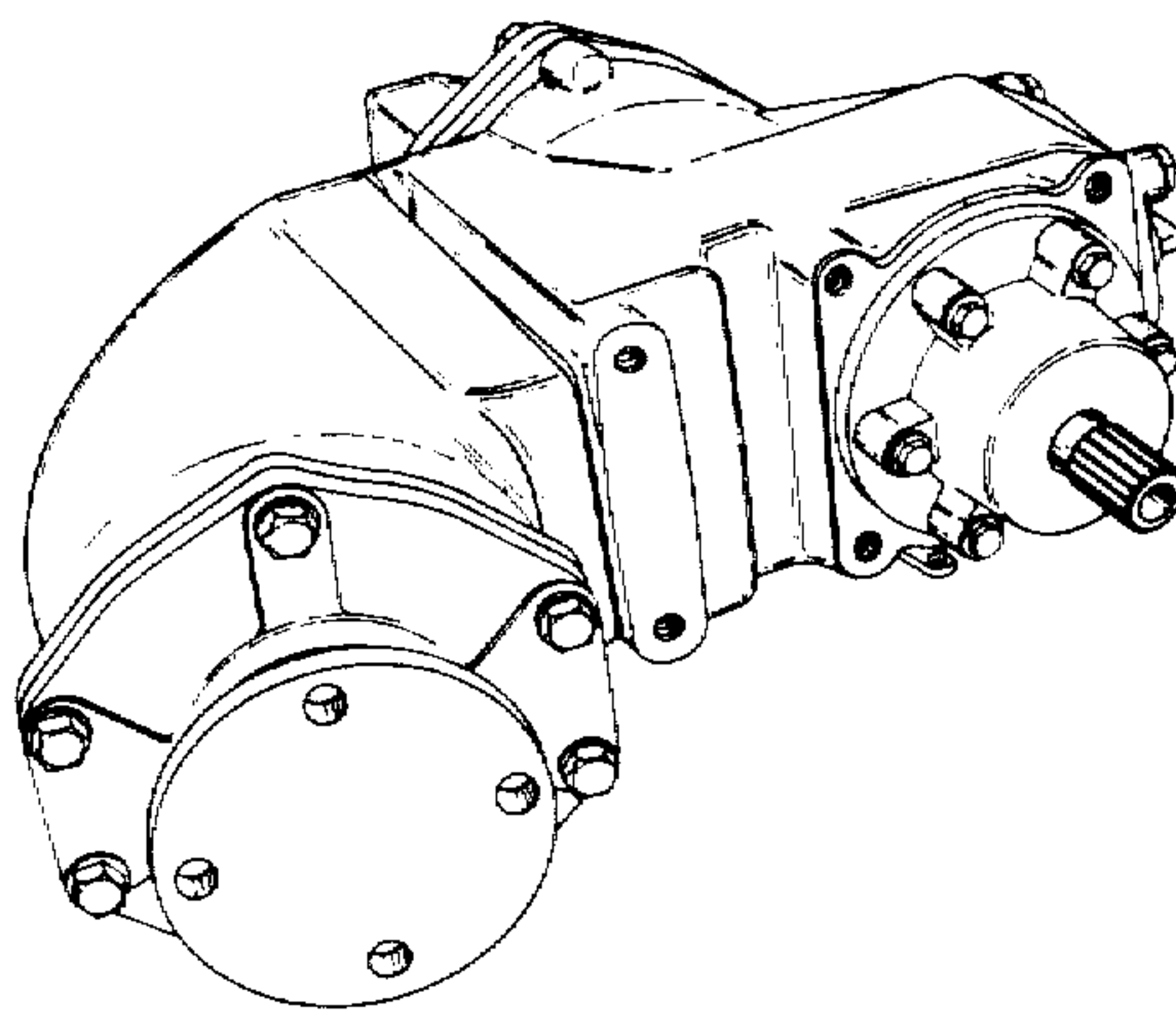
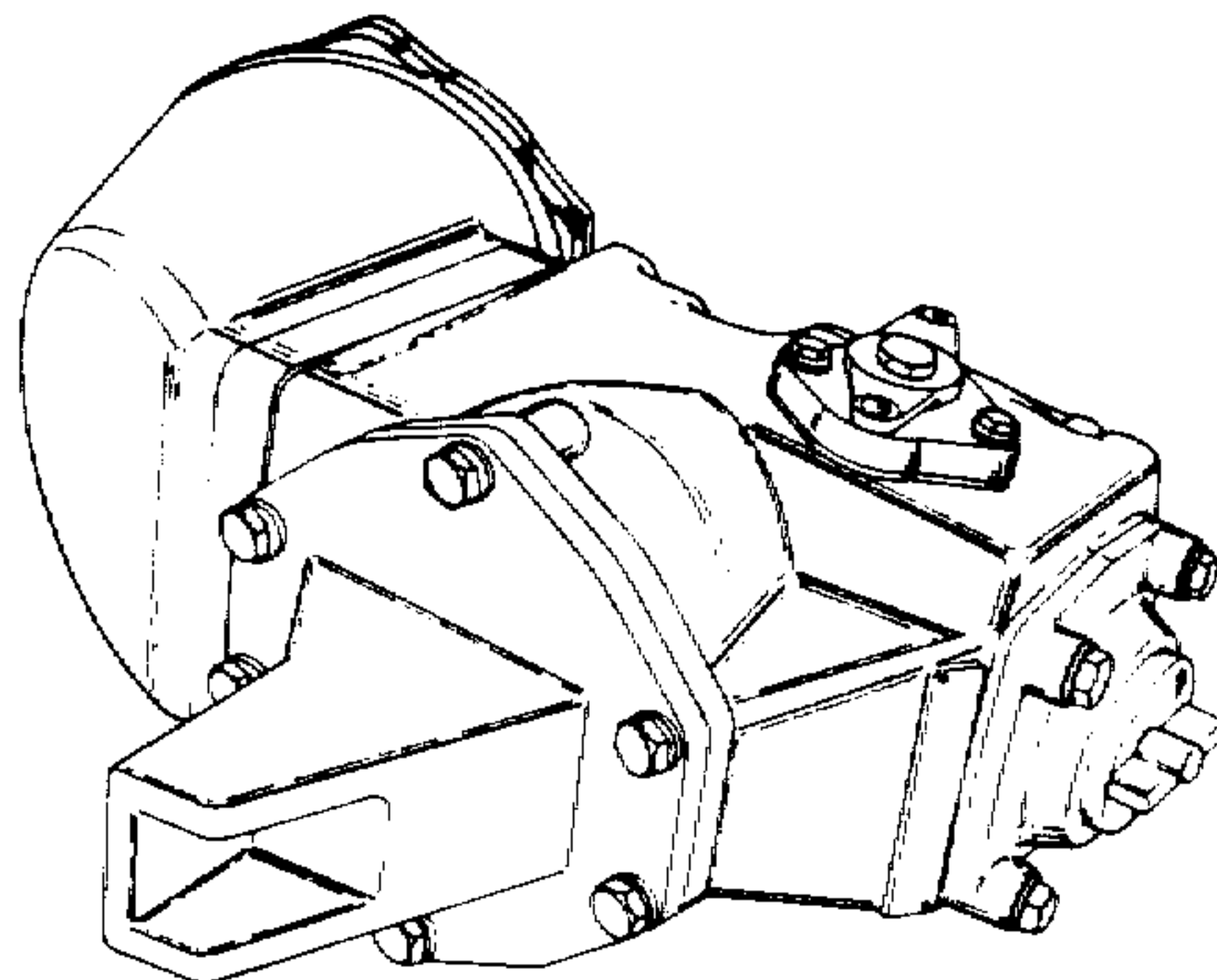

FIG 3

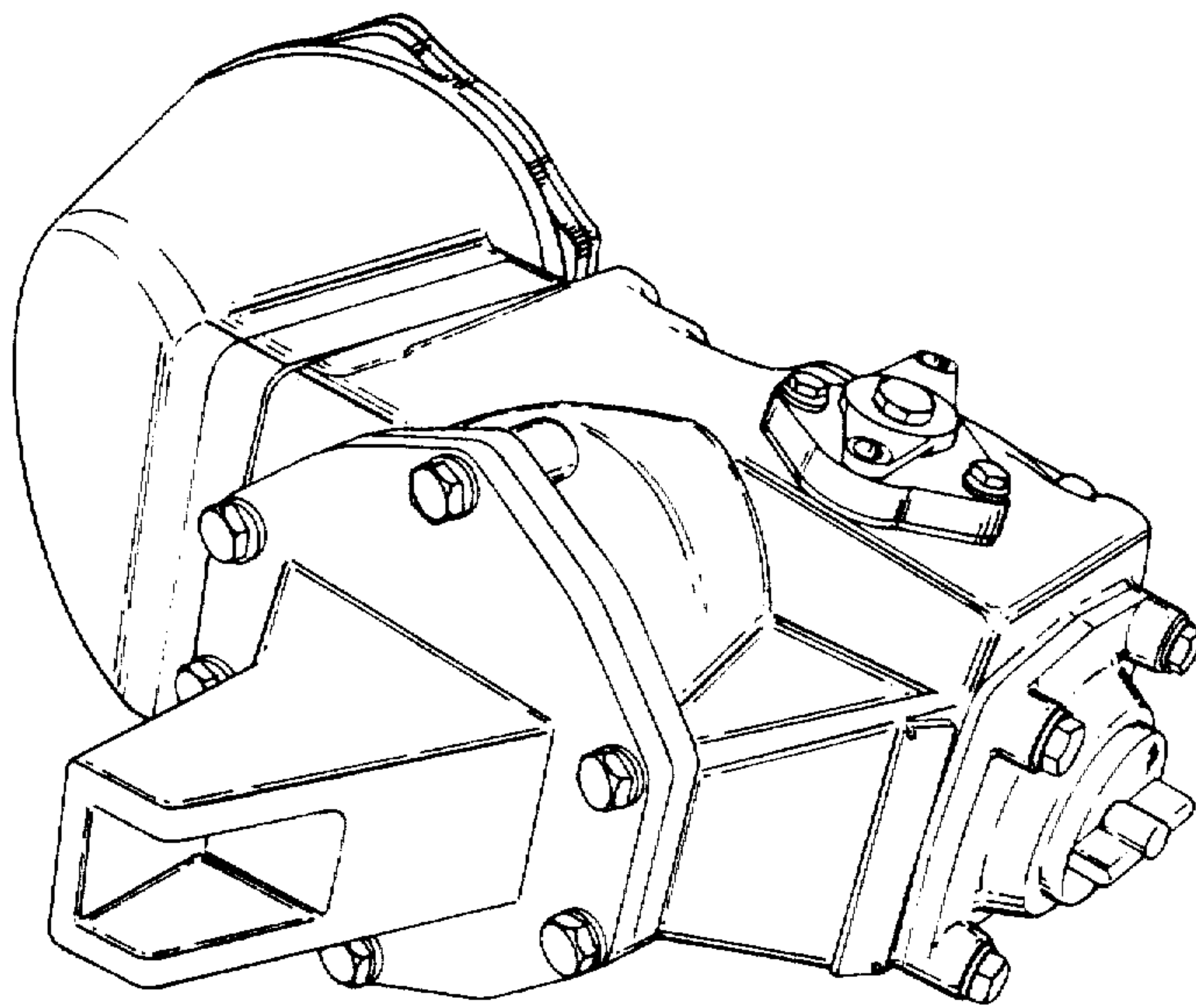

FIG 1

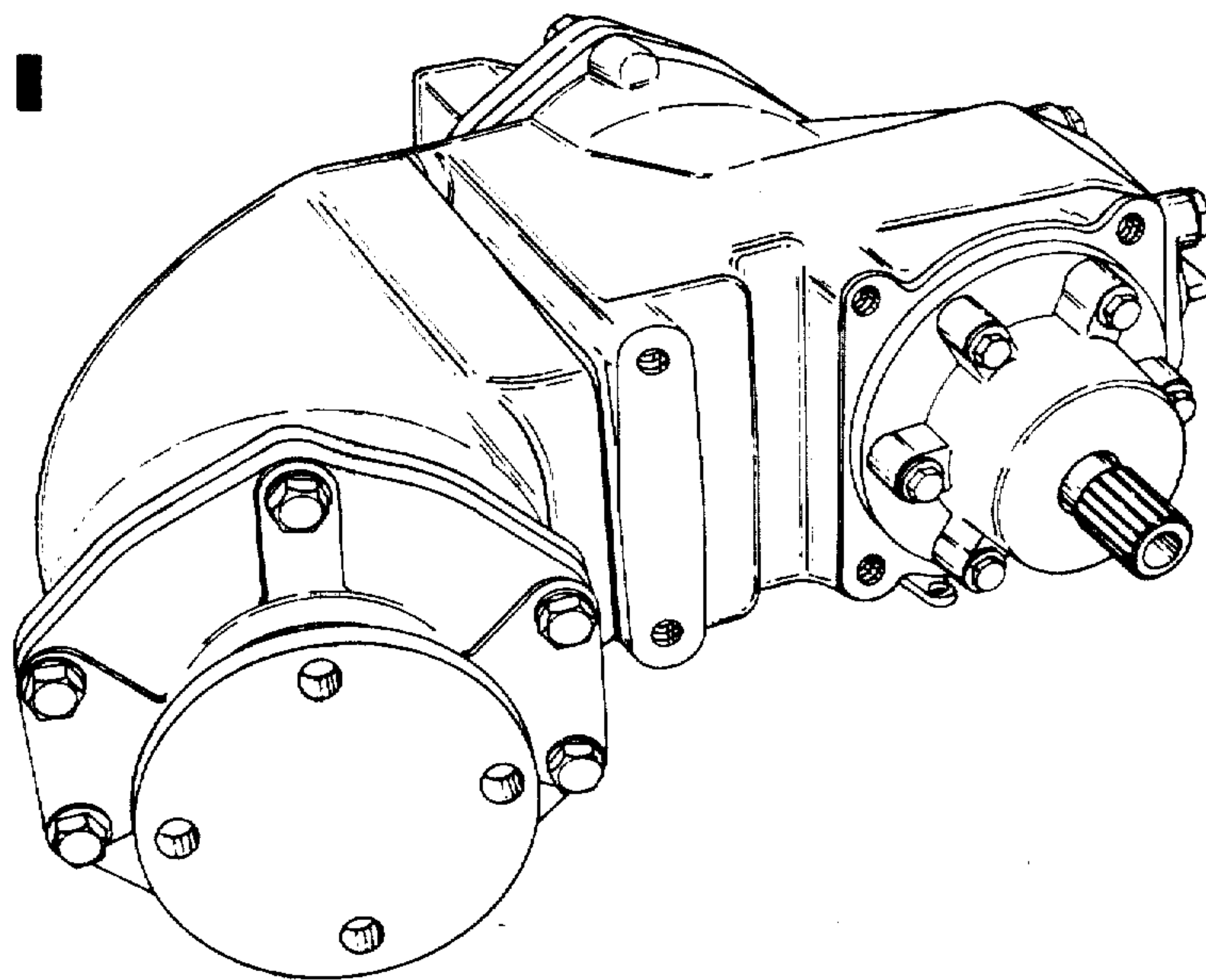

FIG 2

