

- [54] BOAT
- [75] Inventor: James F. Bettis, Elgin, Ill.
- [73] Assignee: Skivette Corporation, Elgin, Ill.
- [\*\*] Term: 14 Years
- [21] Appl. No.: 46,241
- [22] Filed: Jun. 7, 1979
- [51] Int. Cl. .... D12-06
- [52] U.S. Cl. .... D12/300; D12/309;  
D12/311
- [58] Field of Search ..... D12/62, 300, 309, 311,  
D12/314, 313; 114/56, 61, 270, 271, 288, 289,  
290; 9/6 R, 6 P, 6 M, 6 W; 46/93

- 3,475,773 11/1969 Codman ..... 9/1.5
- 3,790,977 2/1974 Bombardier et al. .... 9/6 P
- 3,989,002 11/1976 Peterson ..... 114/270

OTHER PUBLICATIONS

Sanger Catalogue, lowermost boat on page.

Primary Examiner—T. Tung

Attorney, Agent, or Firm—Rummler & Snow

[57] CLAIM

The ornamental design for a boat, as shown.

DESCRIPTION

FIG. 1 is a perspective view of a boat showing my new design;

FIG. 2 is a side elevational view thereof;

FIG. 3 is a top view thereof;

FIG. 4 is a front elevational view thereof;

FIG. 5 is a rear elevational view thereof; and

FIG. 6 is a bottom view thereof.

- [56] References Cited
- U.S. PATENT DOCUMENTS
- 3,191,572 6/1965 Wilson ..... 114/61

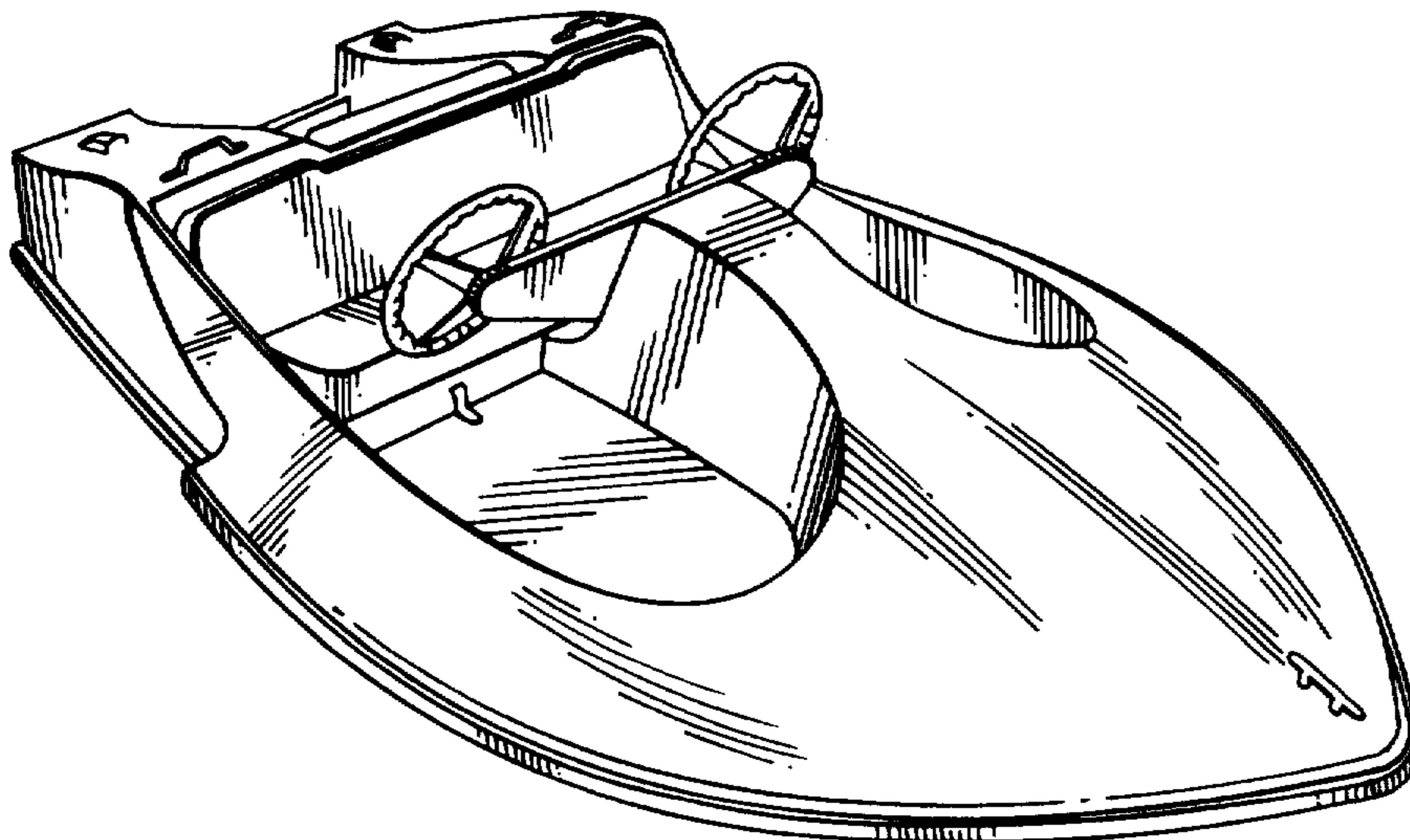

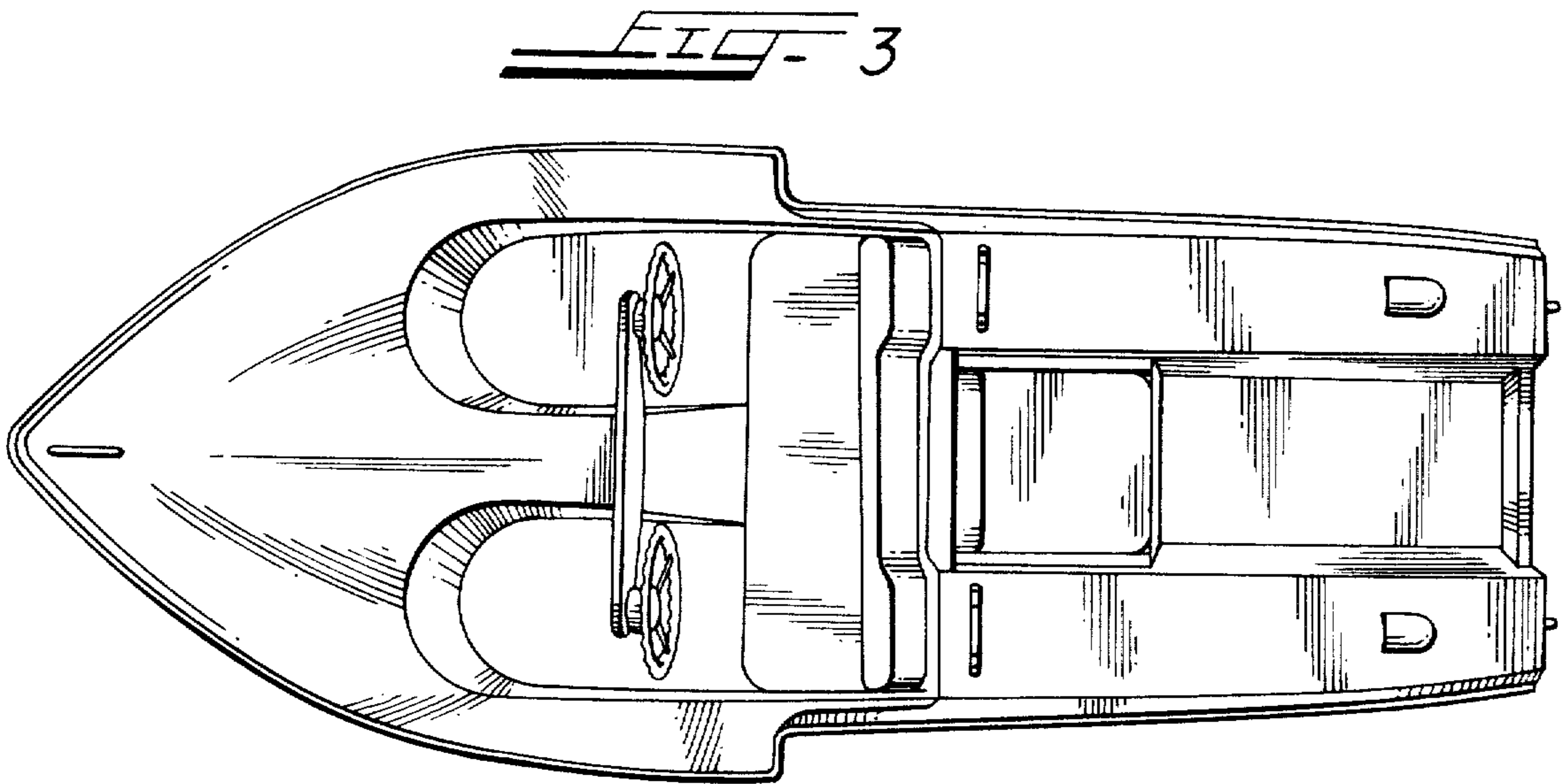
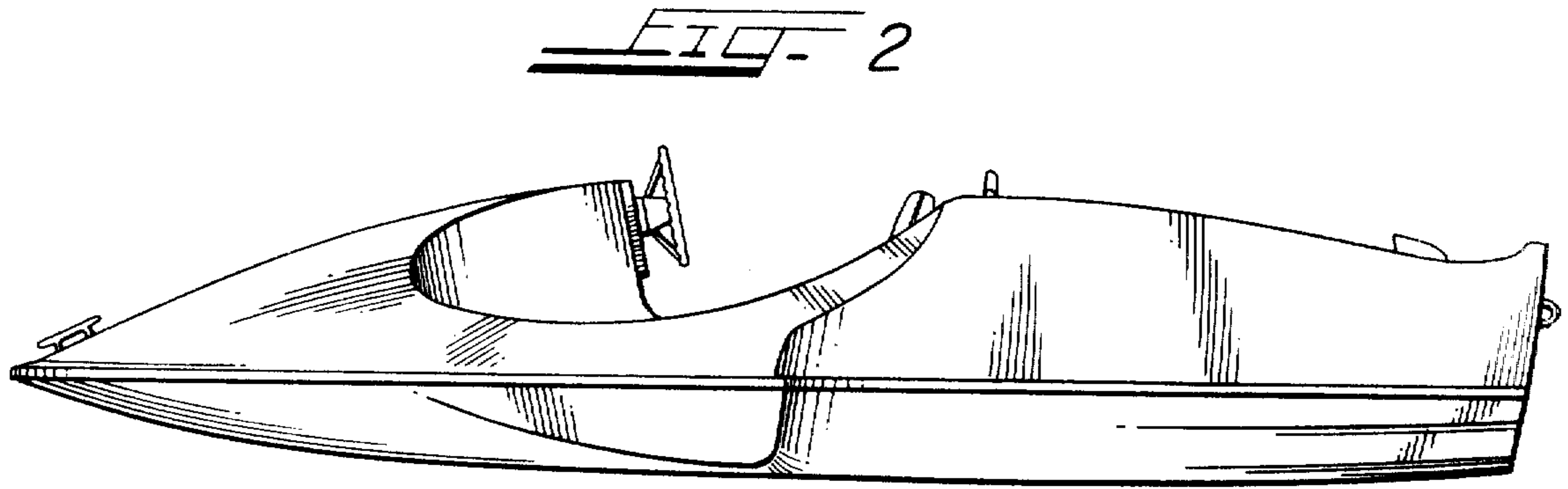
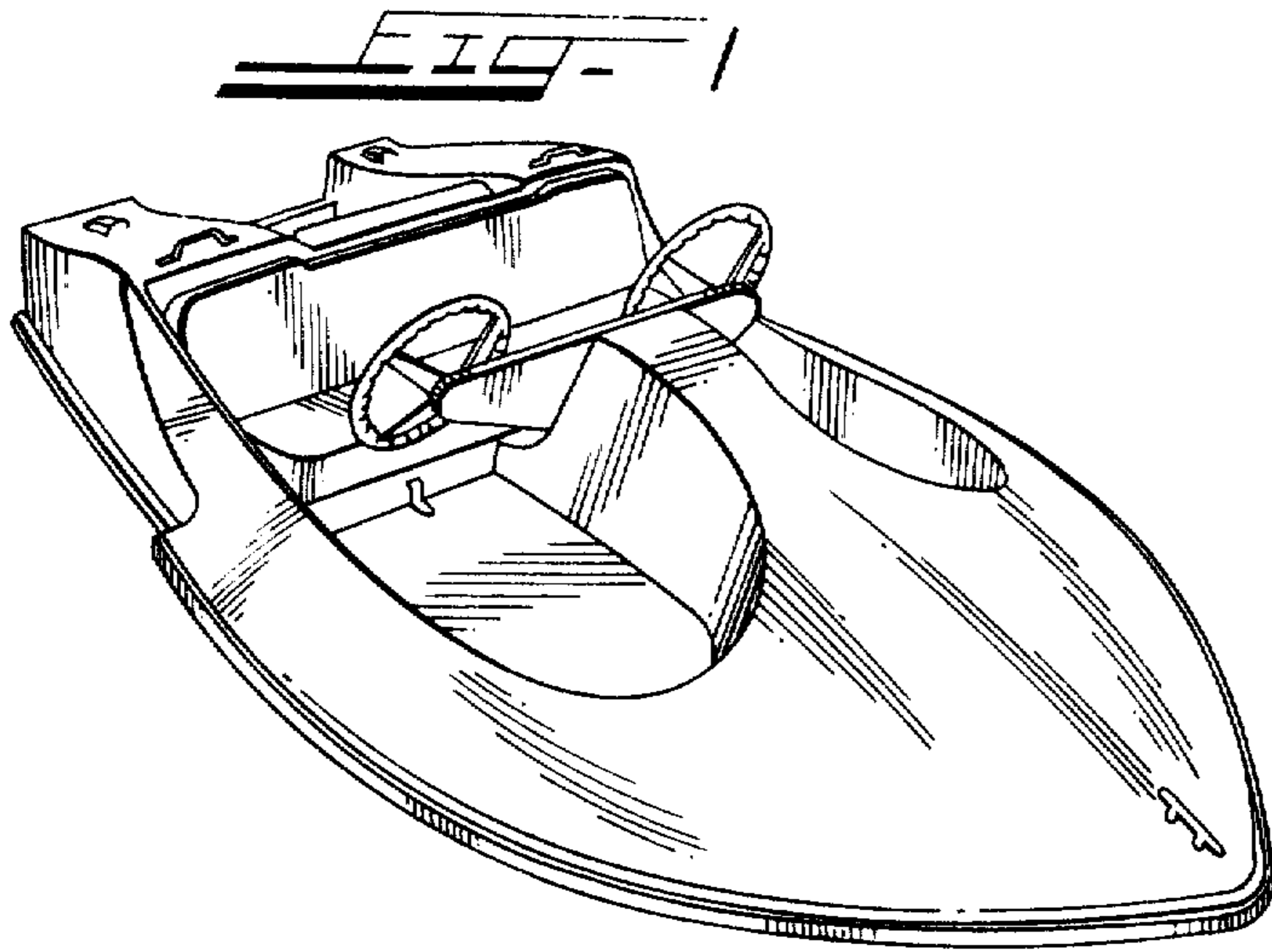

FIG-4

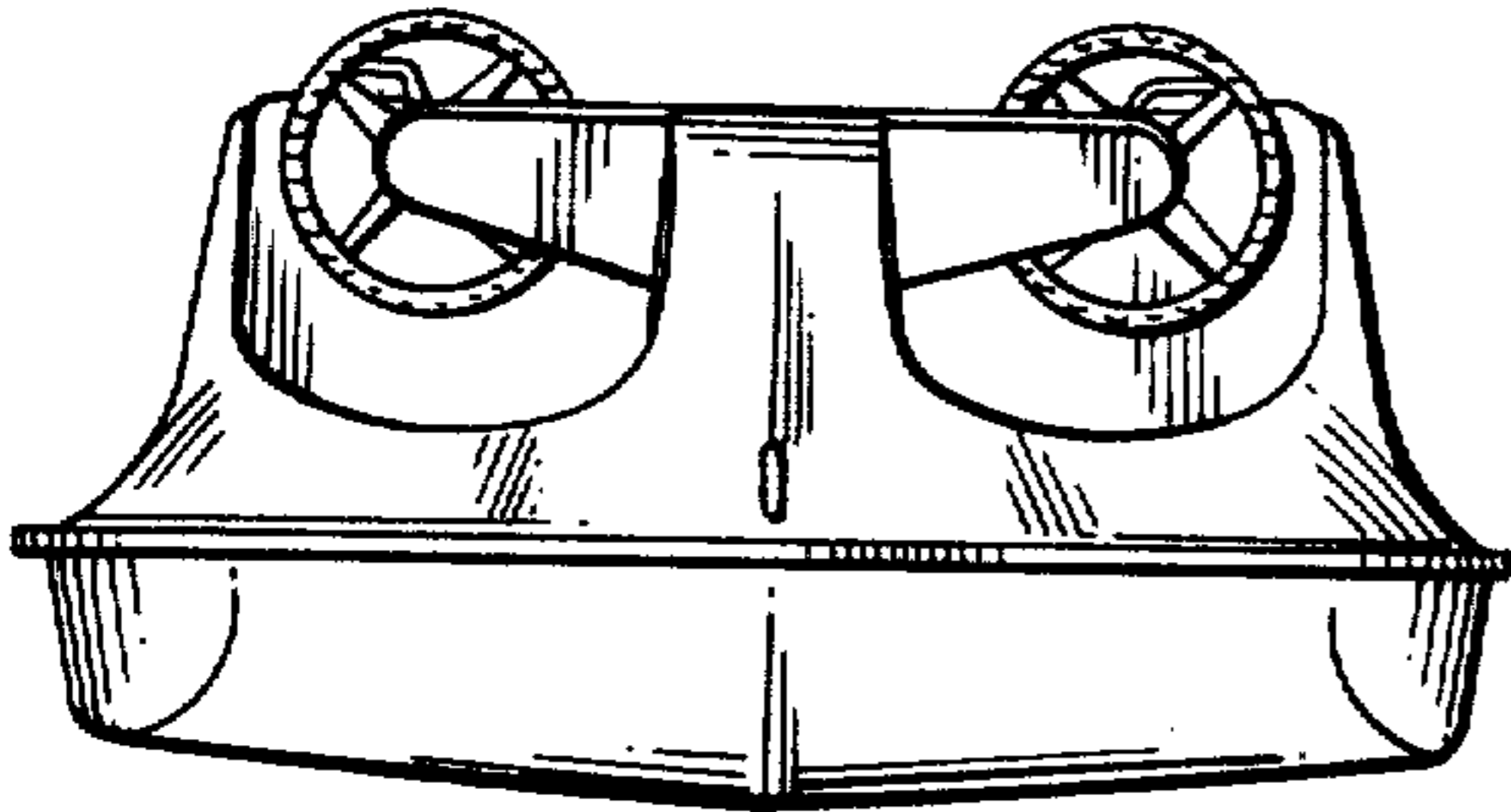

FIG-5

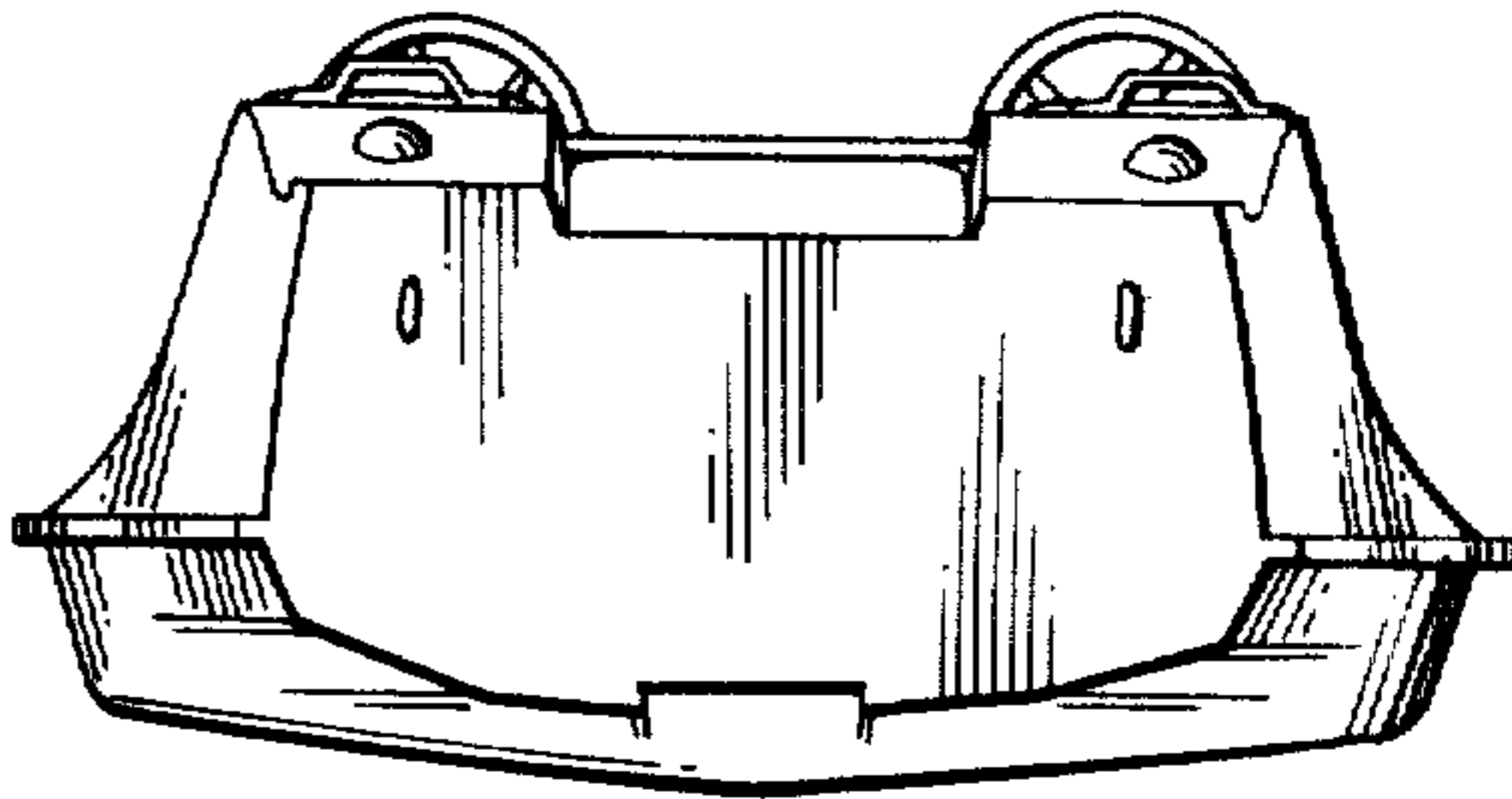

FIG-6

