

- [54] AIR CARGO CONTAINER
- [75] Inventors: Robert P. Evans, Walnut Creek; Dale F. Weiss, Hermosa Beach, both of Calif.
- [73] Assignee: Transequip, Inc., Compton, Calif.
- [\*\*] Term: 14 Years
- [21] Appl. No.: 135,213
- [22] Filed: Mar. 28, 1980
- [51] Int. Cl. .... D3—99
- [52] U.S. Cl. .... D3/30.1; D6/167
- [58] Field of Search ..... D99/44; D3/30.1; 217/5, 217/36; D9/414; D6/160-167

2,023,992	12/1935	Chesler	.....	217/5
2,329,723	9/1943	Lindsey et al.	.....	217/5
3,370,734	2/1968	Wilkins et al.	.....	217/5

Primary Examiner—Robert C. Spangler  
 Attorney, Agent, or Firm—Freilich, Hornbaker, Wasserman, Rosen & Fernandez

[57] CLAIM

The ornamental design for an air cargo container, substantially as shown.

DESCRIPTION

FIG. 1 is a perspective view of an air cargo container showing our new design;  
 FIG. 2 is a left end elevational view thereof;  
 FIG. 3 is a front elevational view thereof;  
 FIG. 4 is a sectional view taken on a line 4—4 in FIG. 3;  
 FIG. 5 is a sectional view in perspective taken on a line 5 in FIG. 4;  
 FIG. 6 is a sectional view in perspective taken on a line 6 in FIG. 3.

[56] References Cited  
 U.S. PATENT DOCUMENTS

D. 236,187	8/1975	Van Spronsen	.....	D6/165 X
D. 255,628	7/1980	Van Koert	.....	D6/167 X
D. 258,331	2/1981	Brown	.....	D6/166 X
2,019,083	10/1935	Loftin	.....	217/5

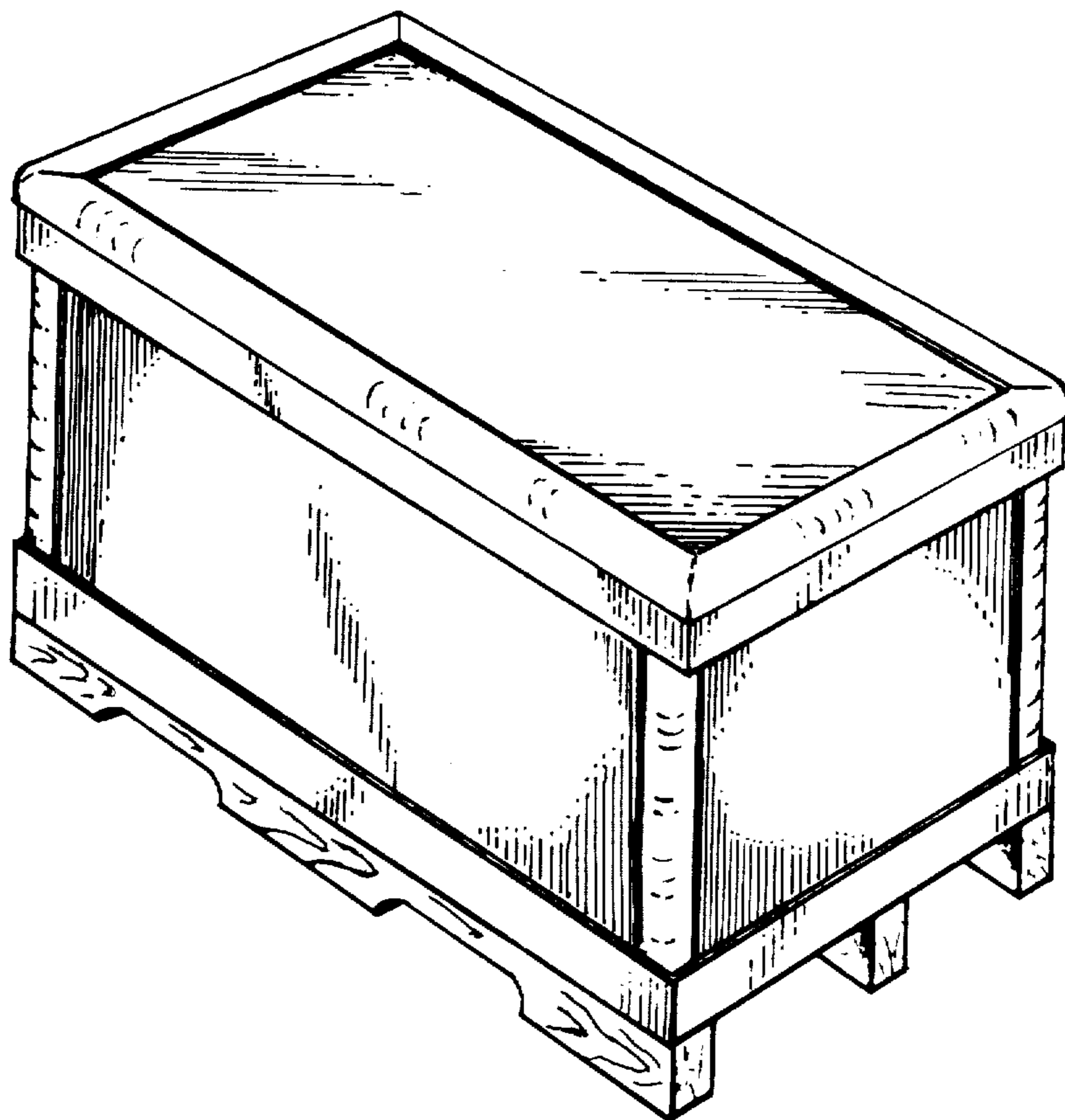

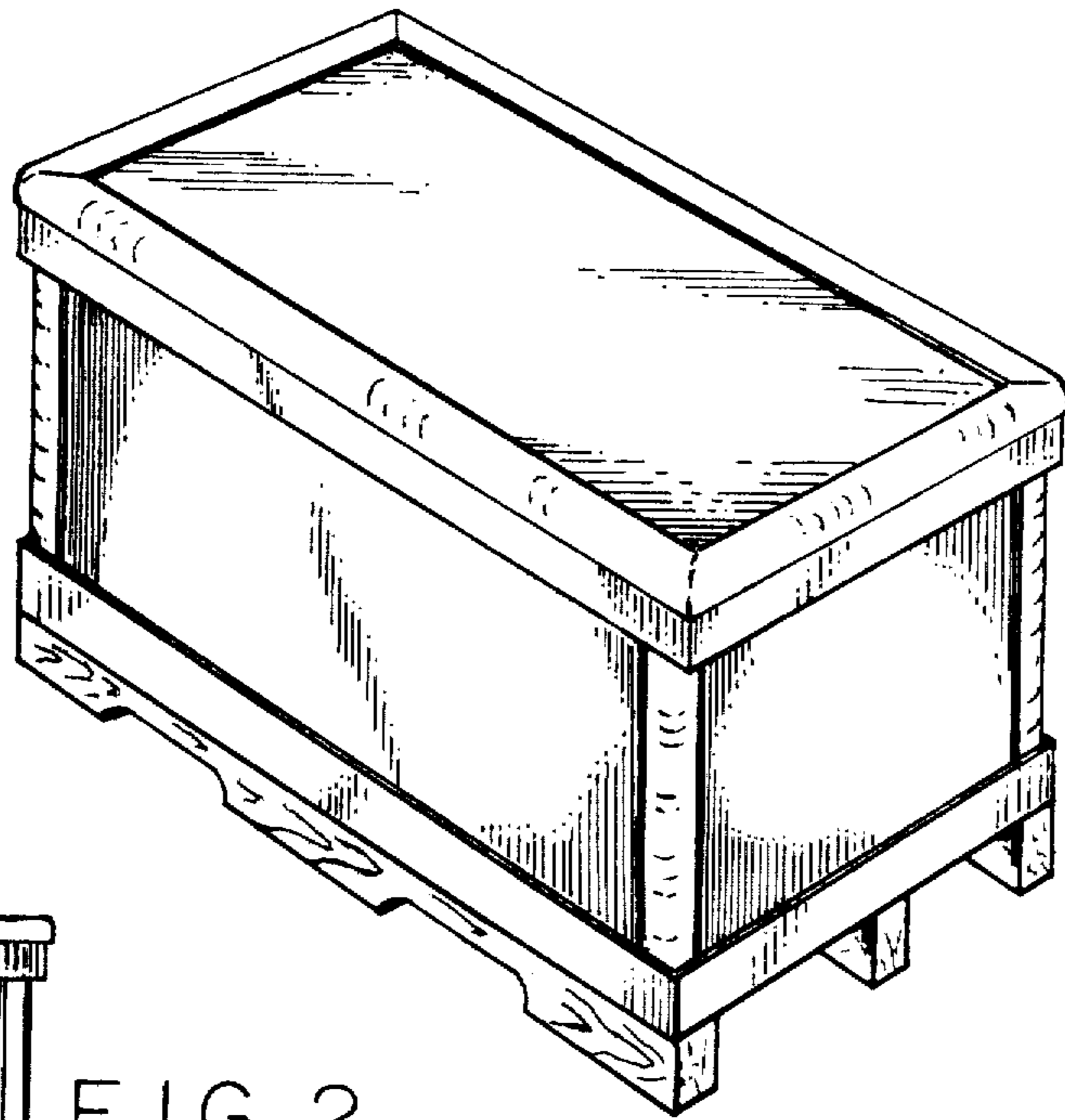

FIG. 1

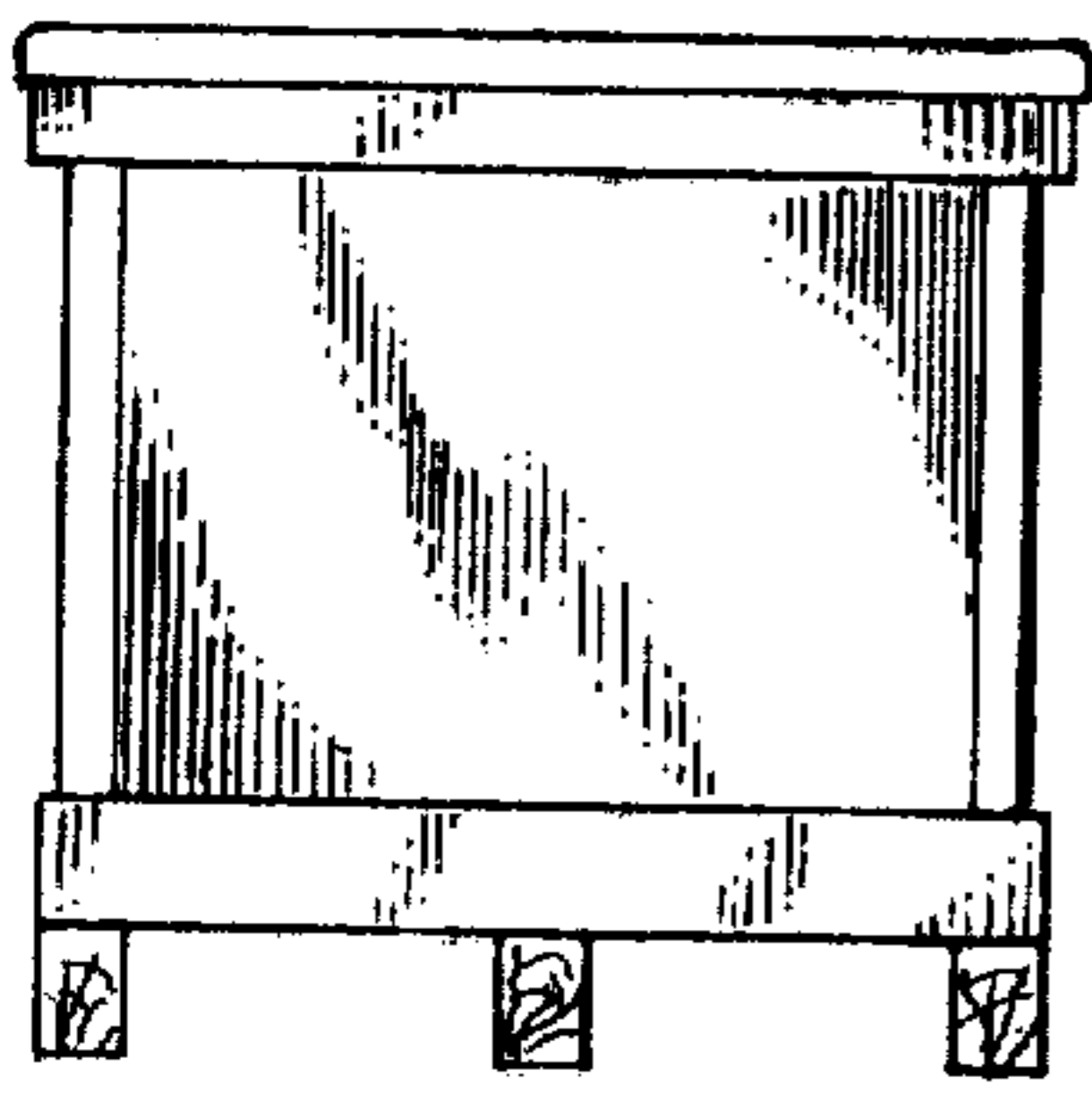

FIG. 2

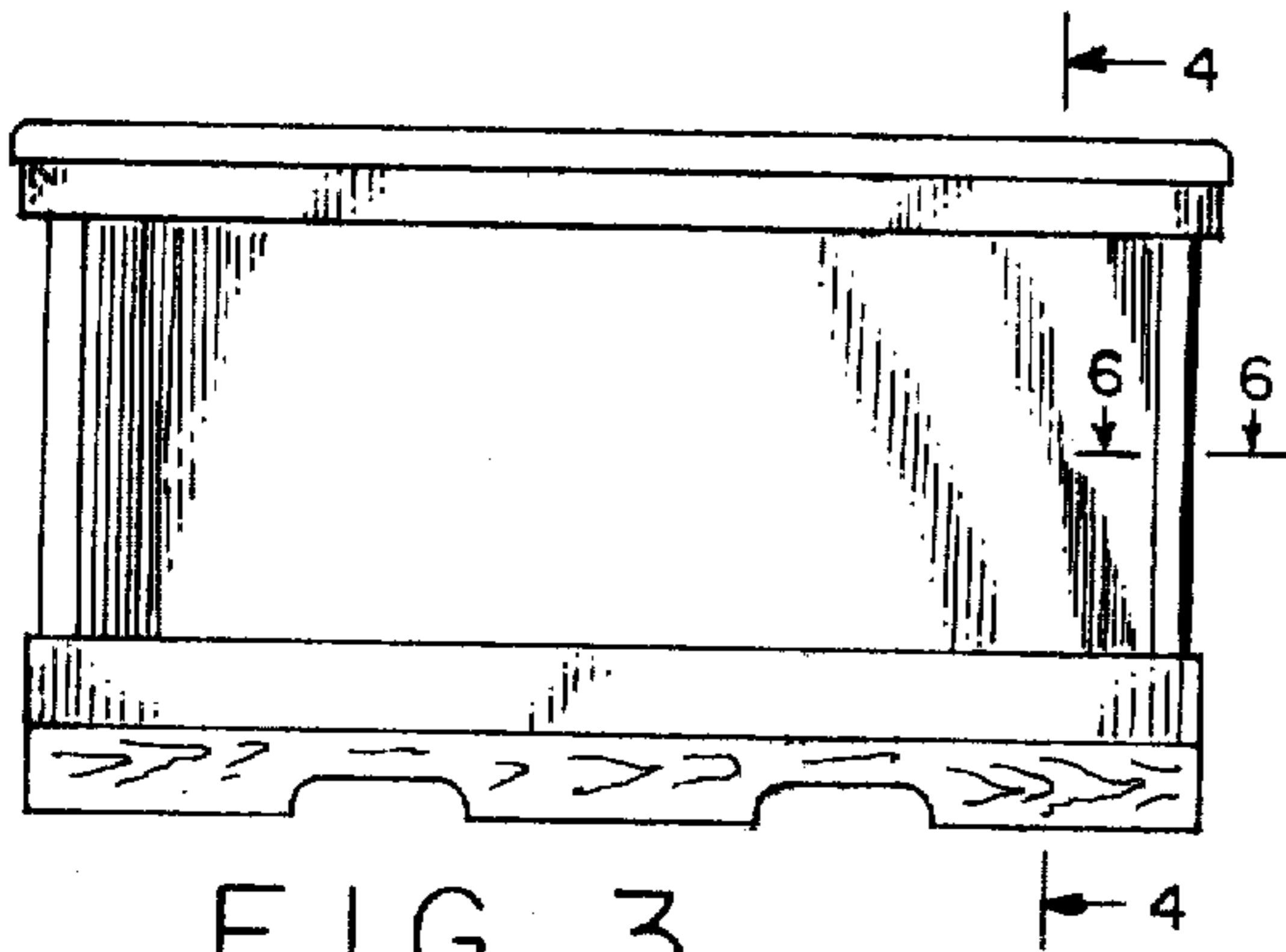

FIG. 3

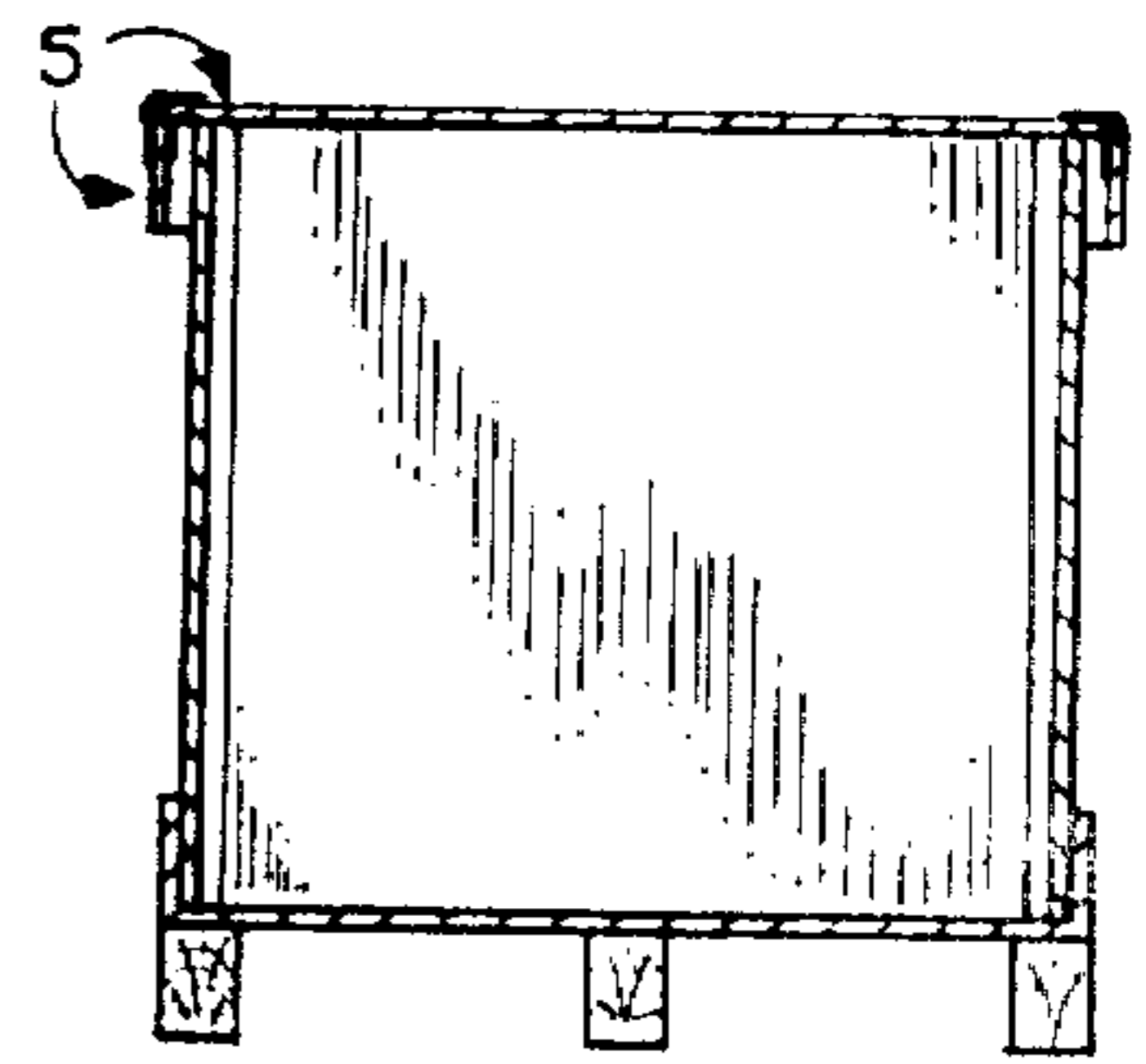

FIG. 4

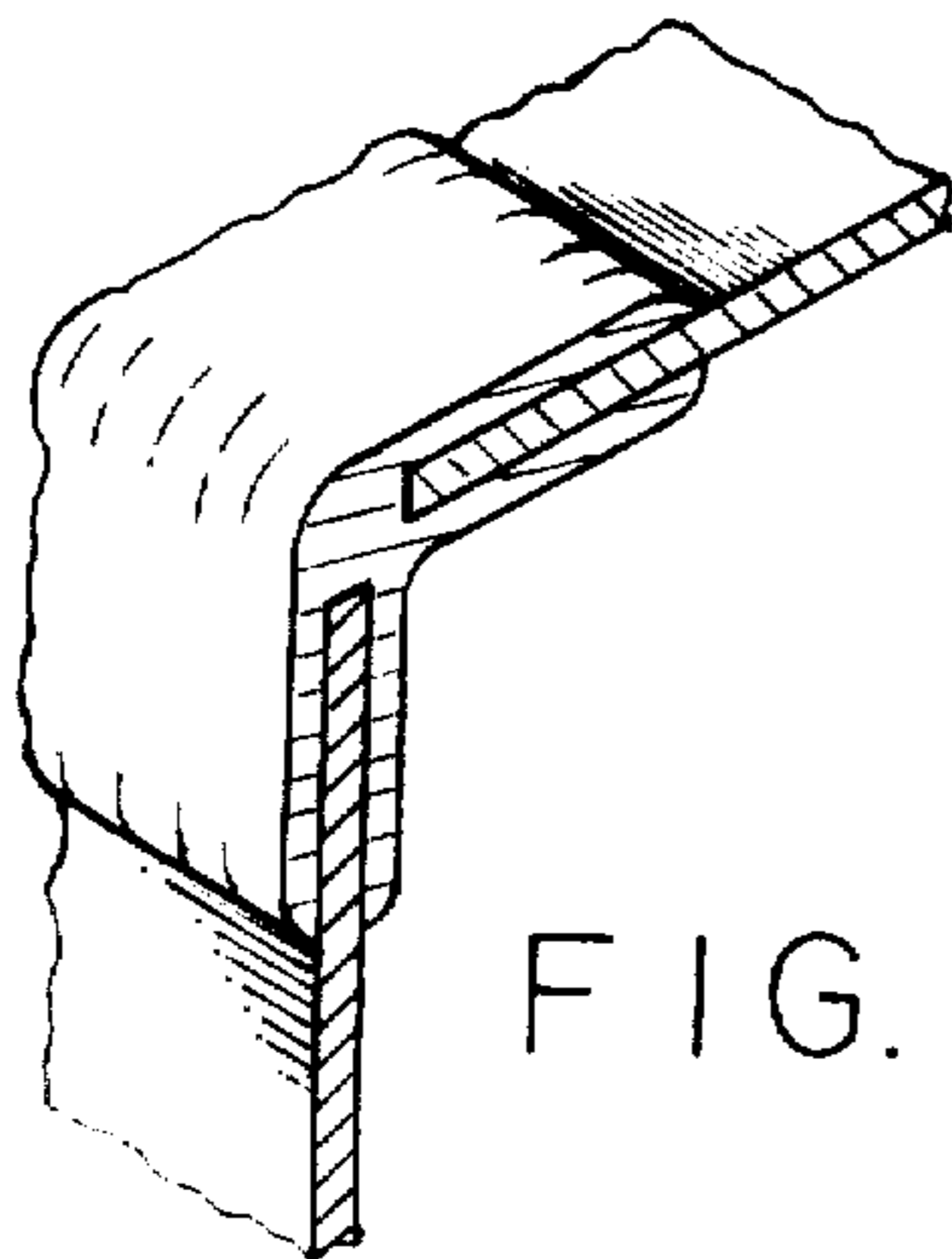

FIG. 5

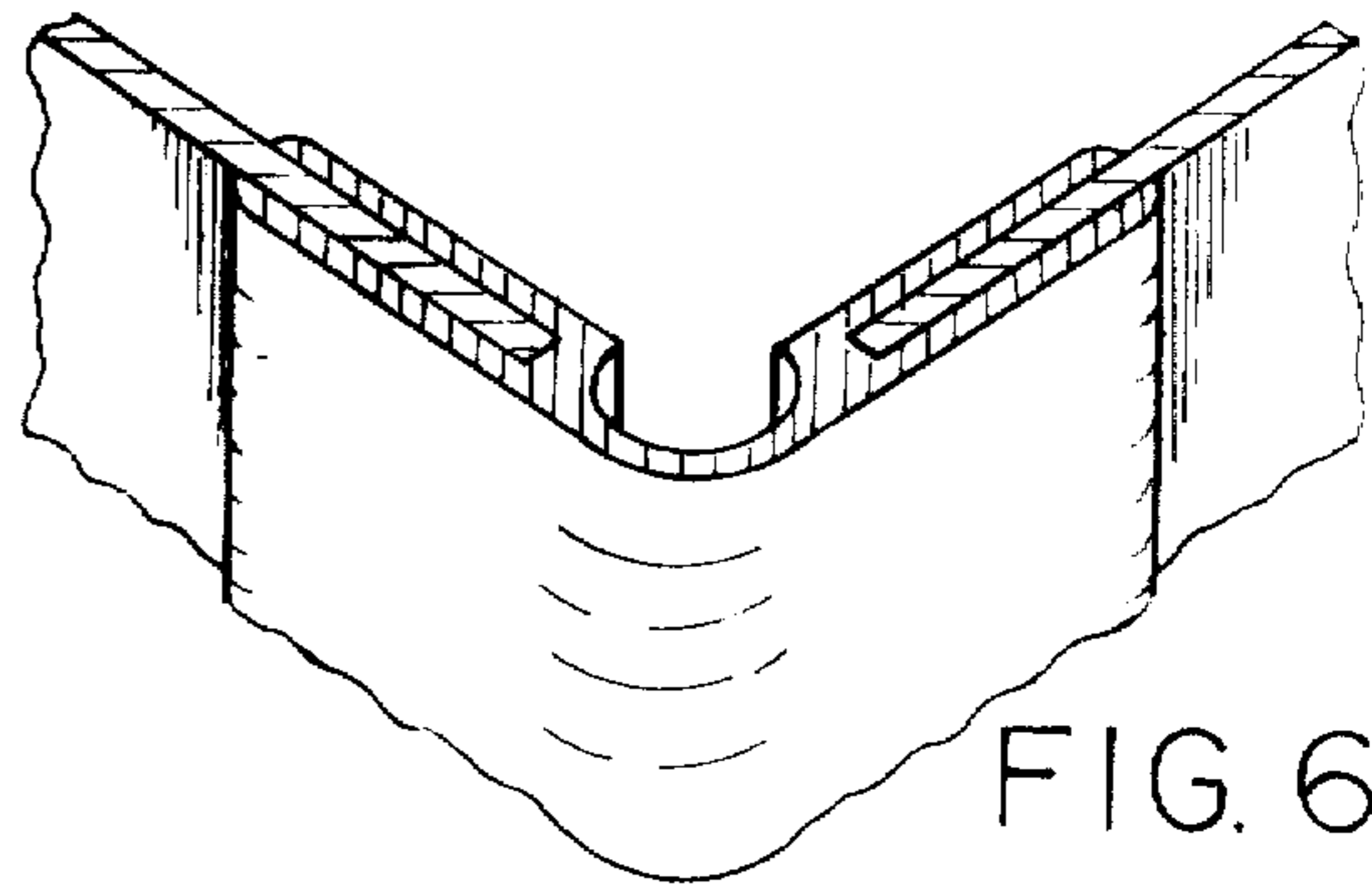

FIG. 6