

[54] ANTI-SWAY ATTACHMENT FOR DUMP TRAILER

[75] Inventor: David R. Neilson, 809 Second St., Woodland, Calif. 95695

[73] Assignees: David R. Neilson, Woodland; Loren H. Taber, Capay; Stefan Fuchslin, Woodland, all of Calif.

[**] Term: 14 Years

[21] Appl. No.: 67,101

[22] Filed: Aug. 16, 1979

[51] Int. Cl. D12-16

[52] U.S. Cl. D12/162

[58] Field of Search D12/162, 155; 298/5; 280/446 B

[56] References Cited

U.S. PATENT DOCUMENTS

4,145,085 3/1979 Taber et al. 298/5

Primary Examiner—James M. Gandy
Attorney, Agent, or Firm—Lothrop & West

[57] CLAIM

The ornamental design for an anti-sway attachment for dump trailer, as shown and described.

DESCRIPTION

FIG. 1 is an elevational view of one side of an anti-sway attachment for dump trailer, showing my new design, the opposite side being a mirror image thereof, the broken line indicating a towing vehicle draft bar forming no part of the design and being shown merely to illustrate the environment;

FIG. 2 is a rear elevational view;

FIG. 3 is a front elevational view;

FIG. 4 is a top plan view;

FIG. 5 is a bottom plan view; and,

FIG. 6 is a sectional view taken along the line 6-6 in FIG. 4.

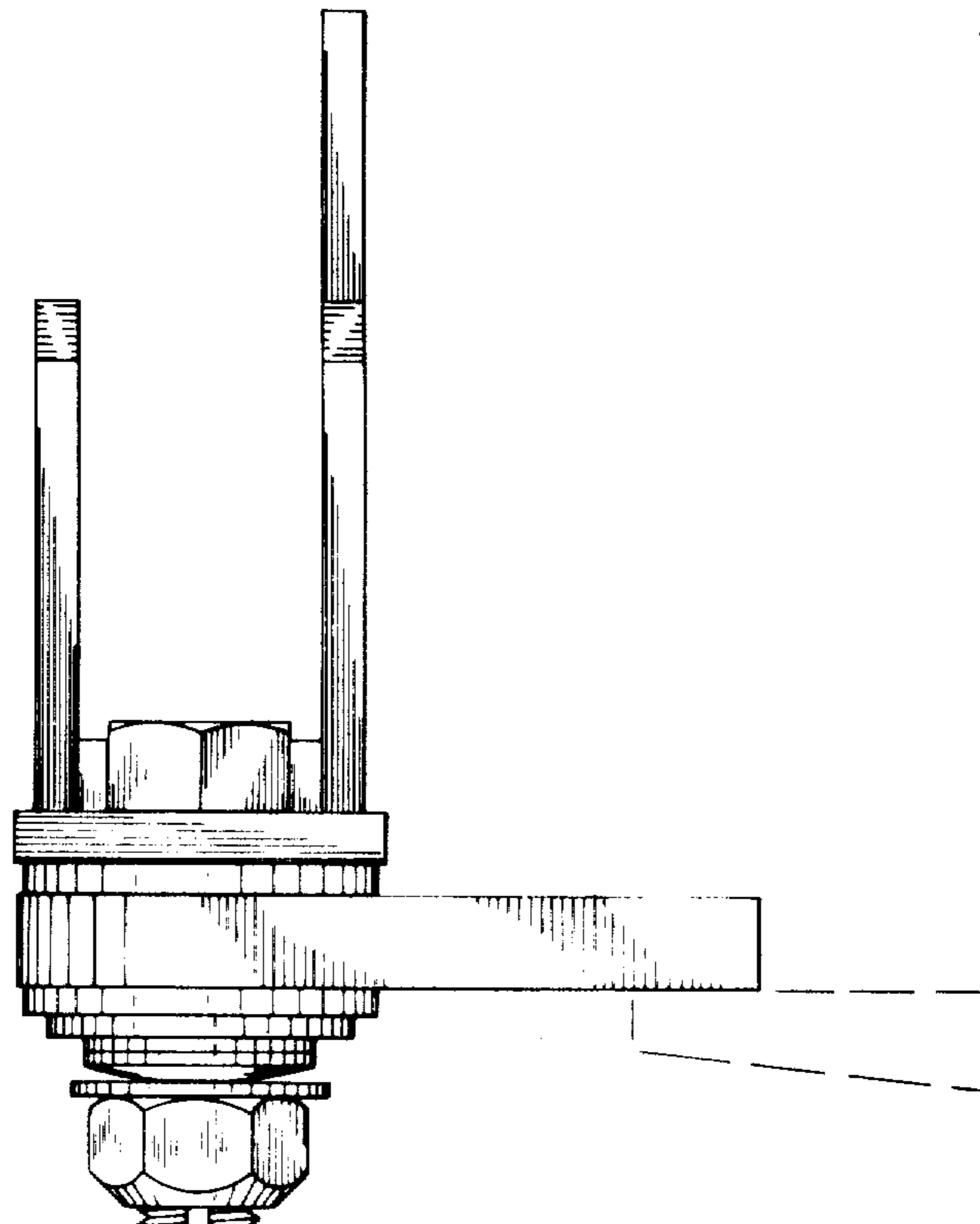

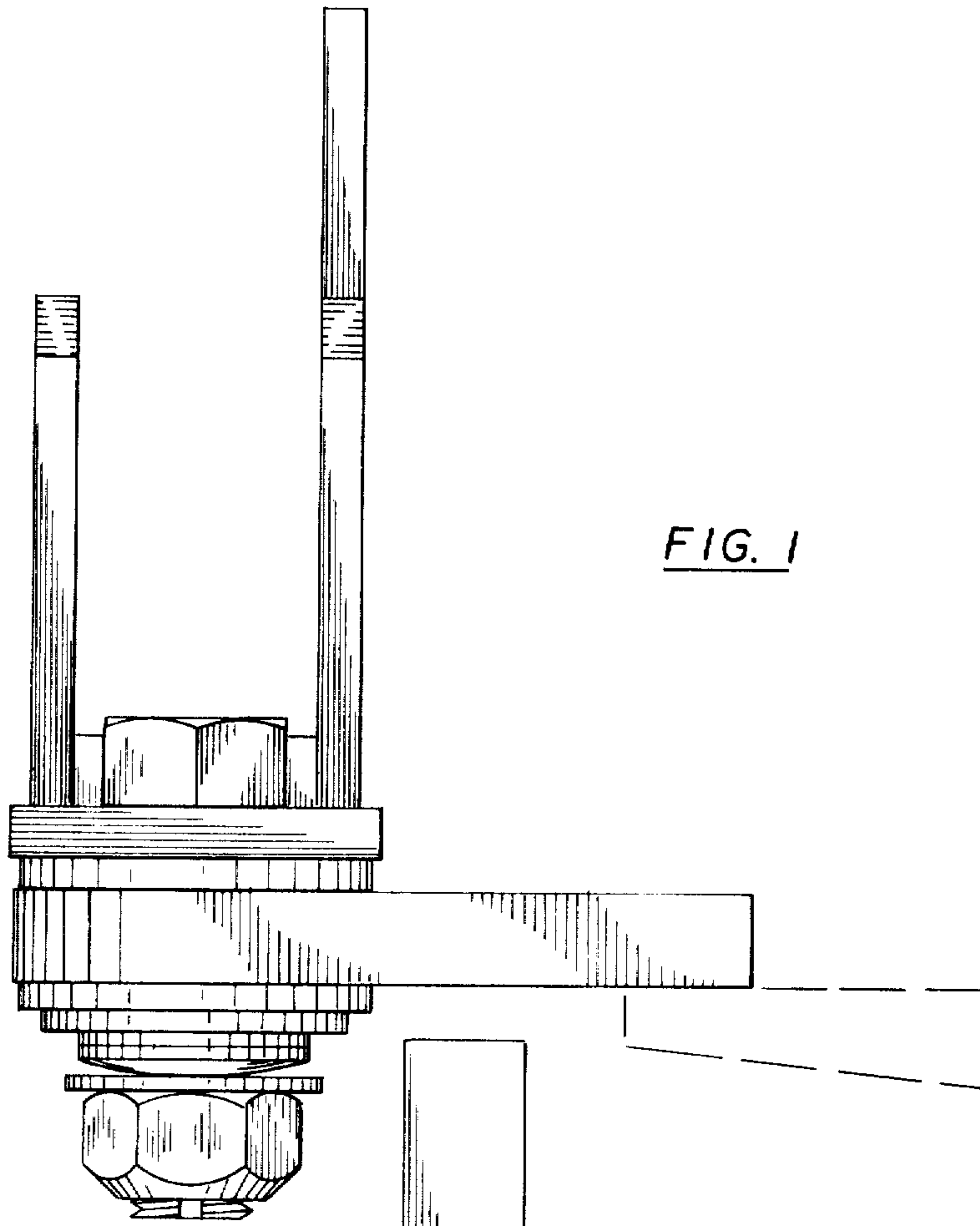

FIG. 1

FIG. 2

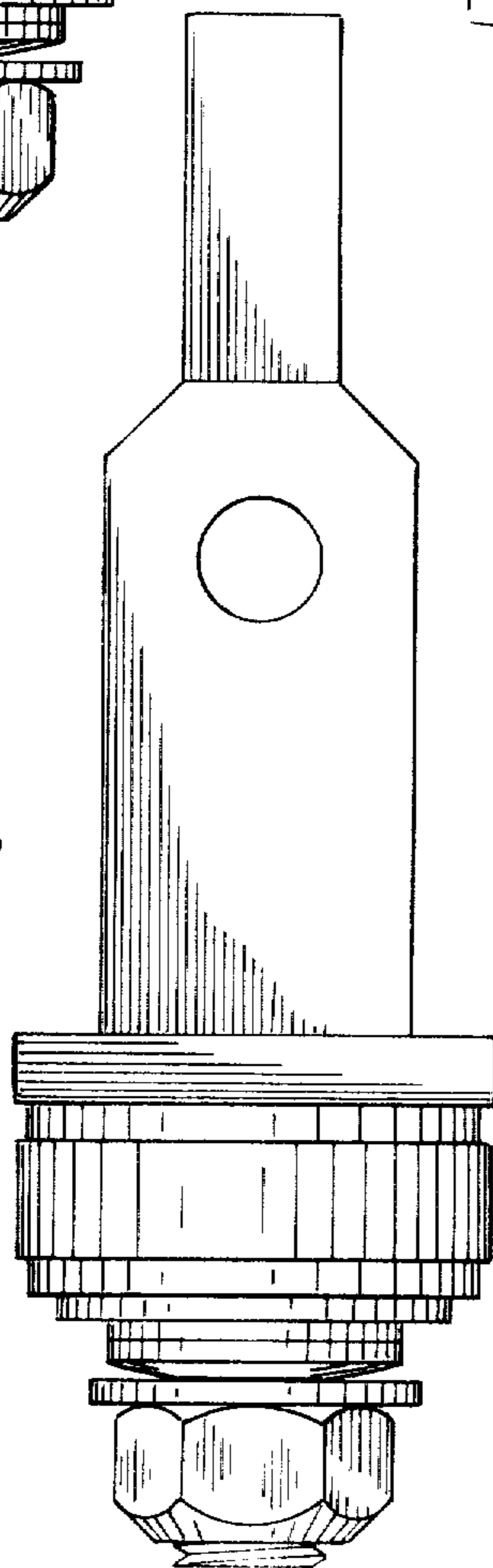

FIG. 3

