

[54] AUTOMOTIVE FUEL CONSUMPTION
ALARM

[76] Inventor: **Raymond P. Smith, Jr.**, P.O. Box 294,
129 Susquehanna St., Williamsport,
Pa. 17701

[**] Term: **14 Years**

[21] Appl. No.: **24,016**

[22] Filed: **Mar. 26, 1979**

[51] Int. Cl. **D10-06**

[52] U.S. Cl. **D10/106**

[58] Field of Search D10/104, 106, 121, 114;
340/52 R, 52 A, 52 B, 52 C, 52 D, 52 F

[56] **References Cited**

U.S. PATENT DOCUMENTS

3,253,256 5/1966 Hull 340/52 R
4,174,766 11/1979 Kalogerson 340/52 D

FOREIGN PATENT DOCUMENTS

2843135 4/1979 Fed. Rep. of Germany 340/52 F

Primary Examiner—Susan J. Lucas
Attorney, Agent, or Firm—Irons and Sears

[57] **CLAIM**

The ornamental design for an automotive fuel consumption alarm, as shown and described.

DESCRIPTION

FIG. 1 in a front perspective view of an automotive fuel consumption alarm showing my new design; FIG. 2 is a front elevation thereof on an enlarged scale; FIG. 3 is a top plan thereof on an enlarged scale; FIG. 4 is a bottom plan thereof on an enlarged scale; FIG. 5 is a rear elevation thereof on an enlarged scale; and FIG. 6 is a right side elevation thereof on an enlarged scale.

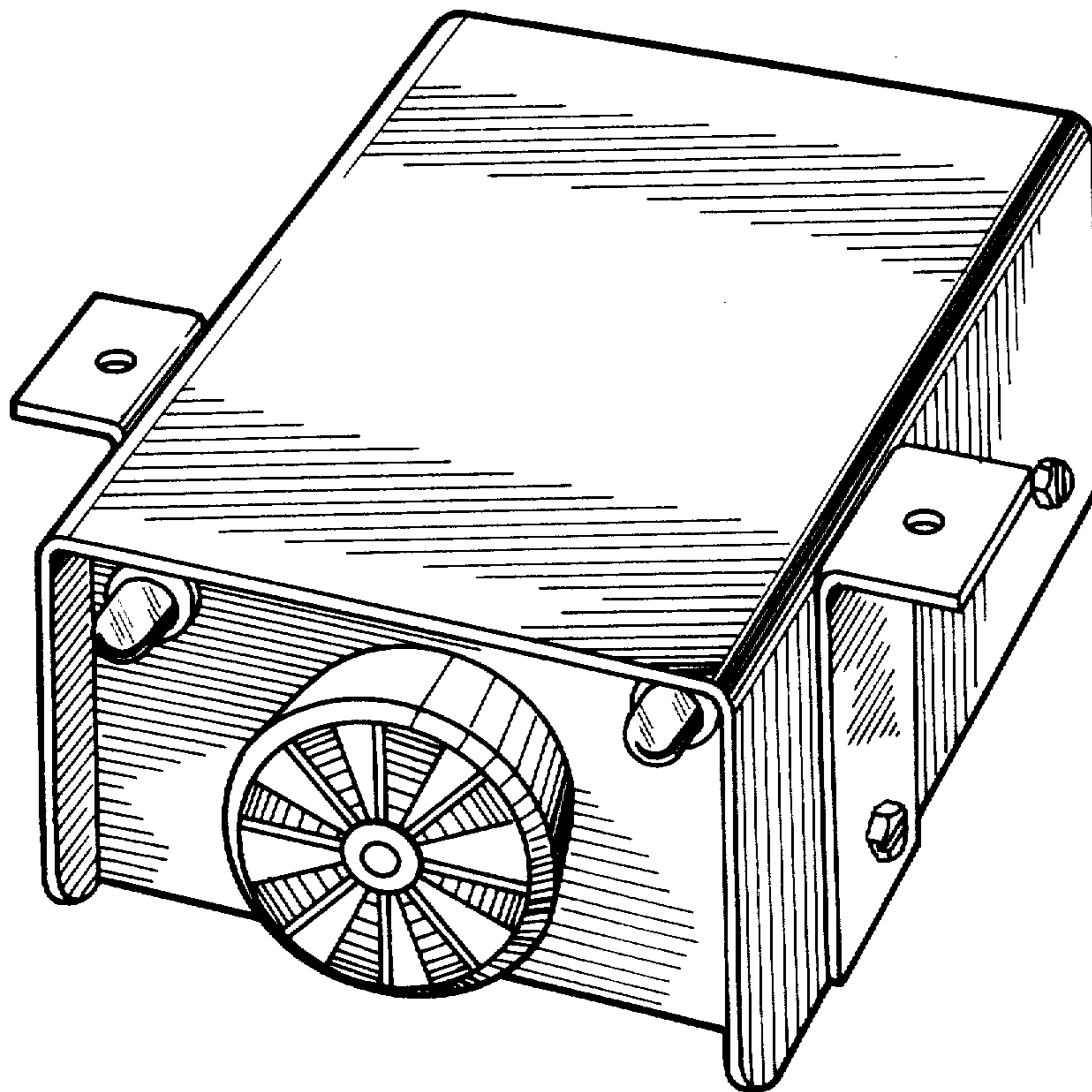

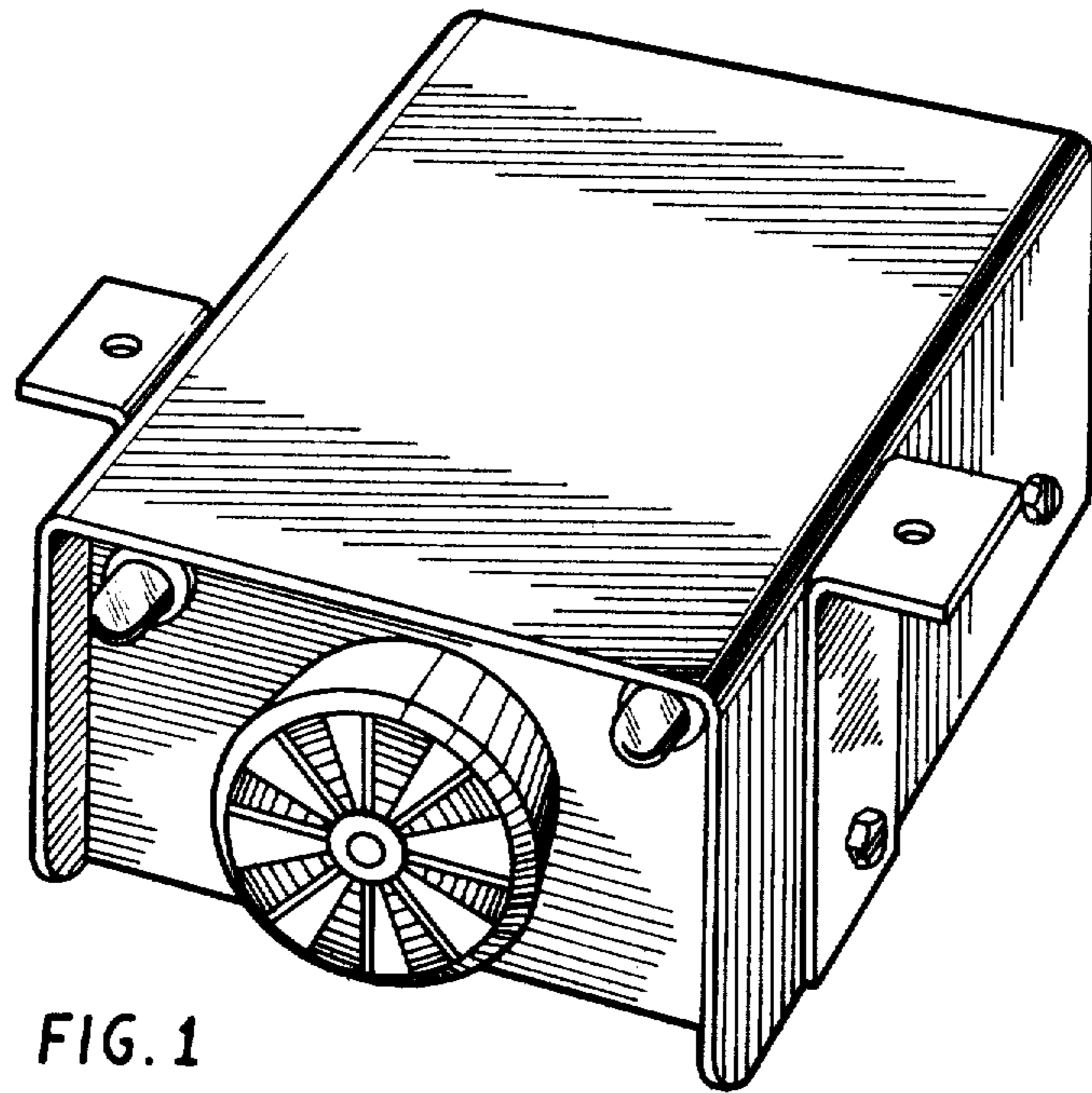

FIG. 1

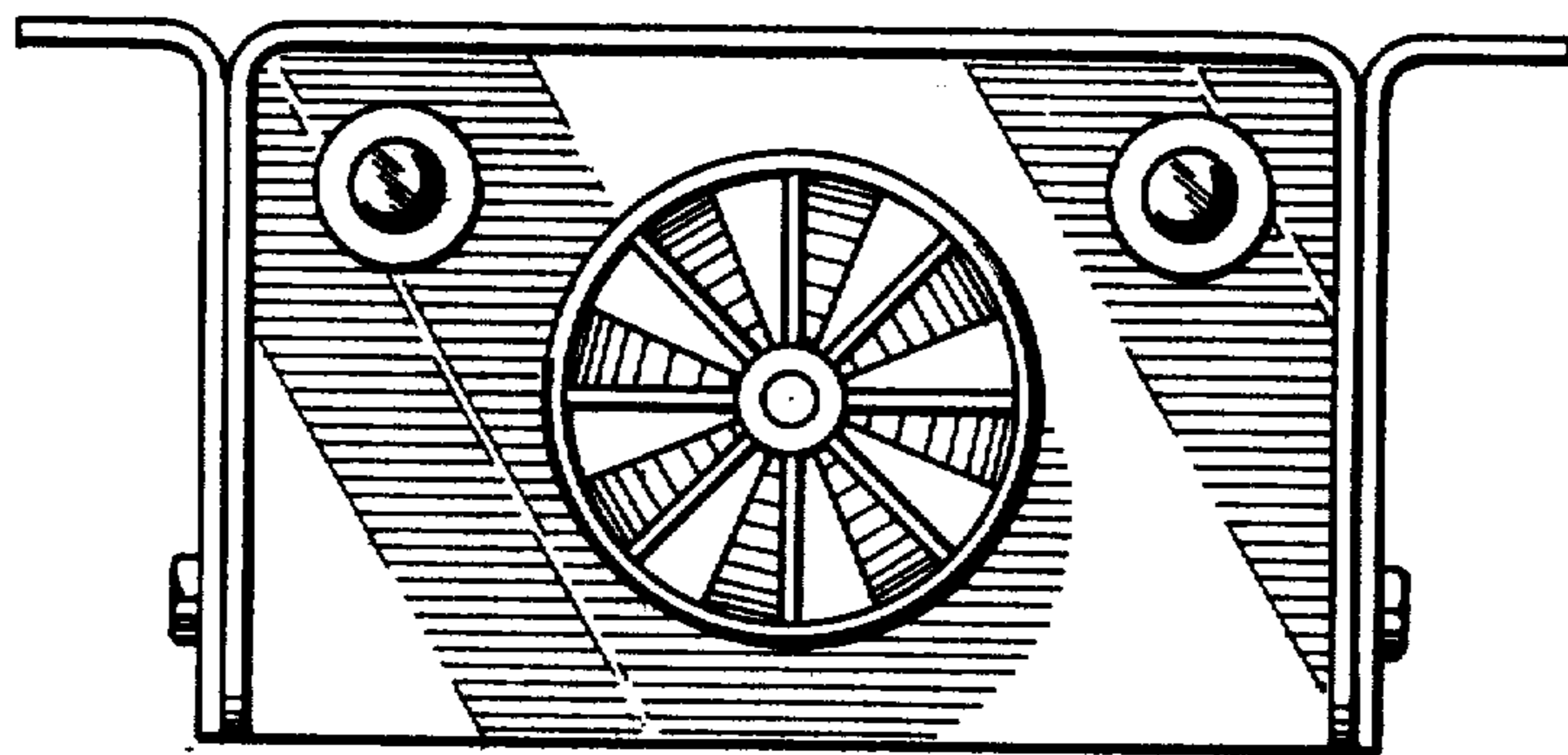

FIG. 2

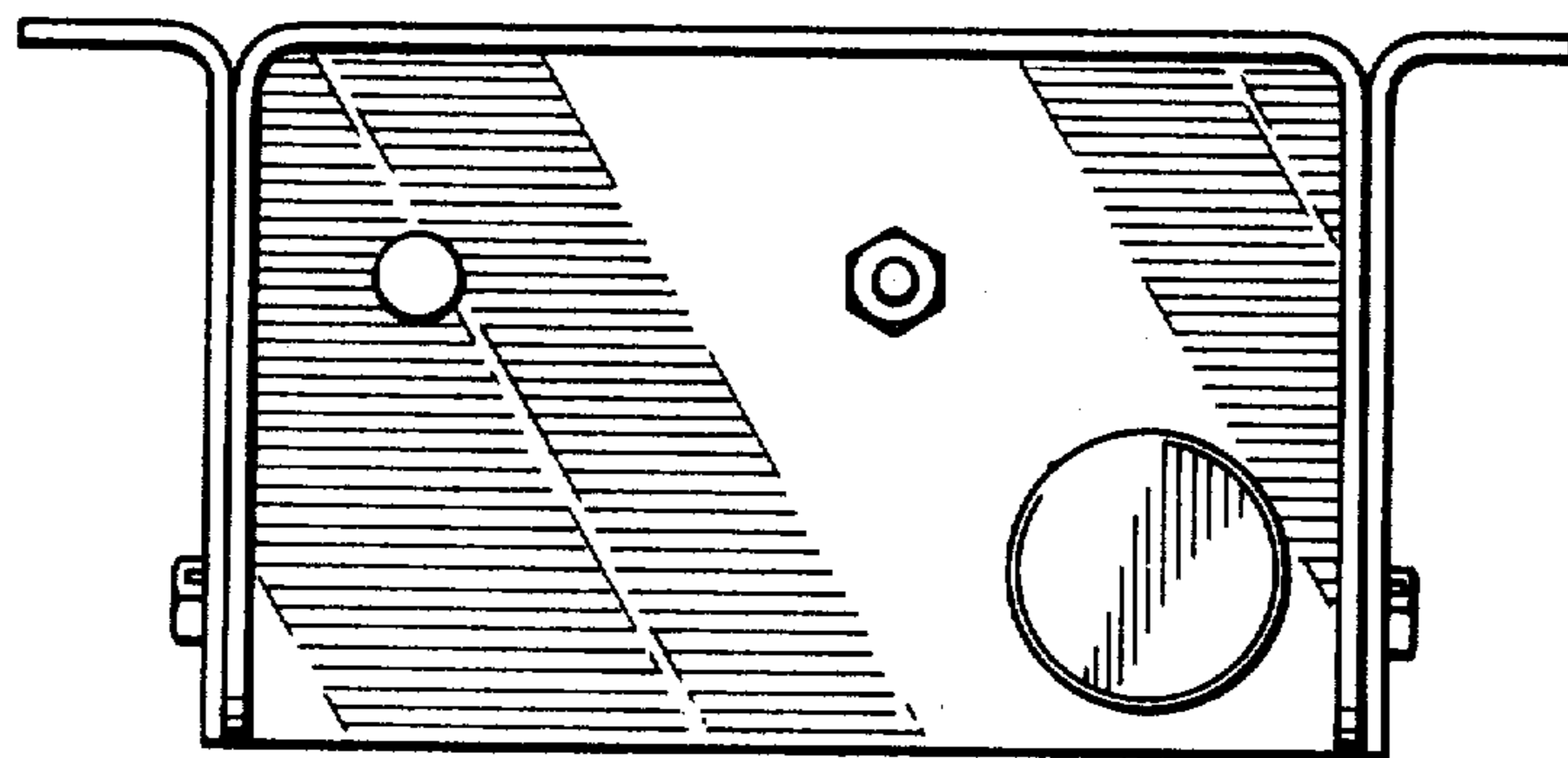

FIG. 5

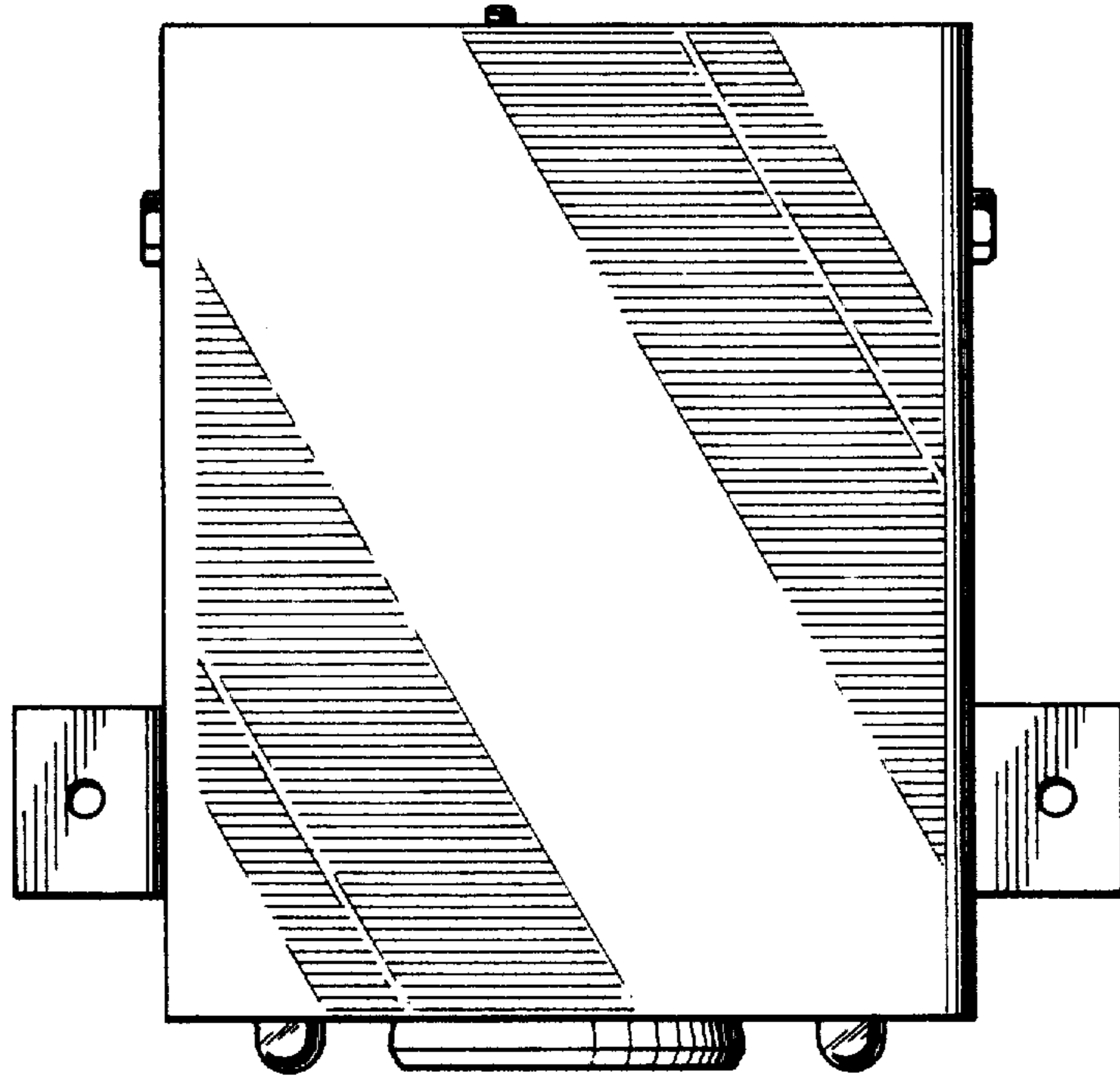

FIG. 3

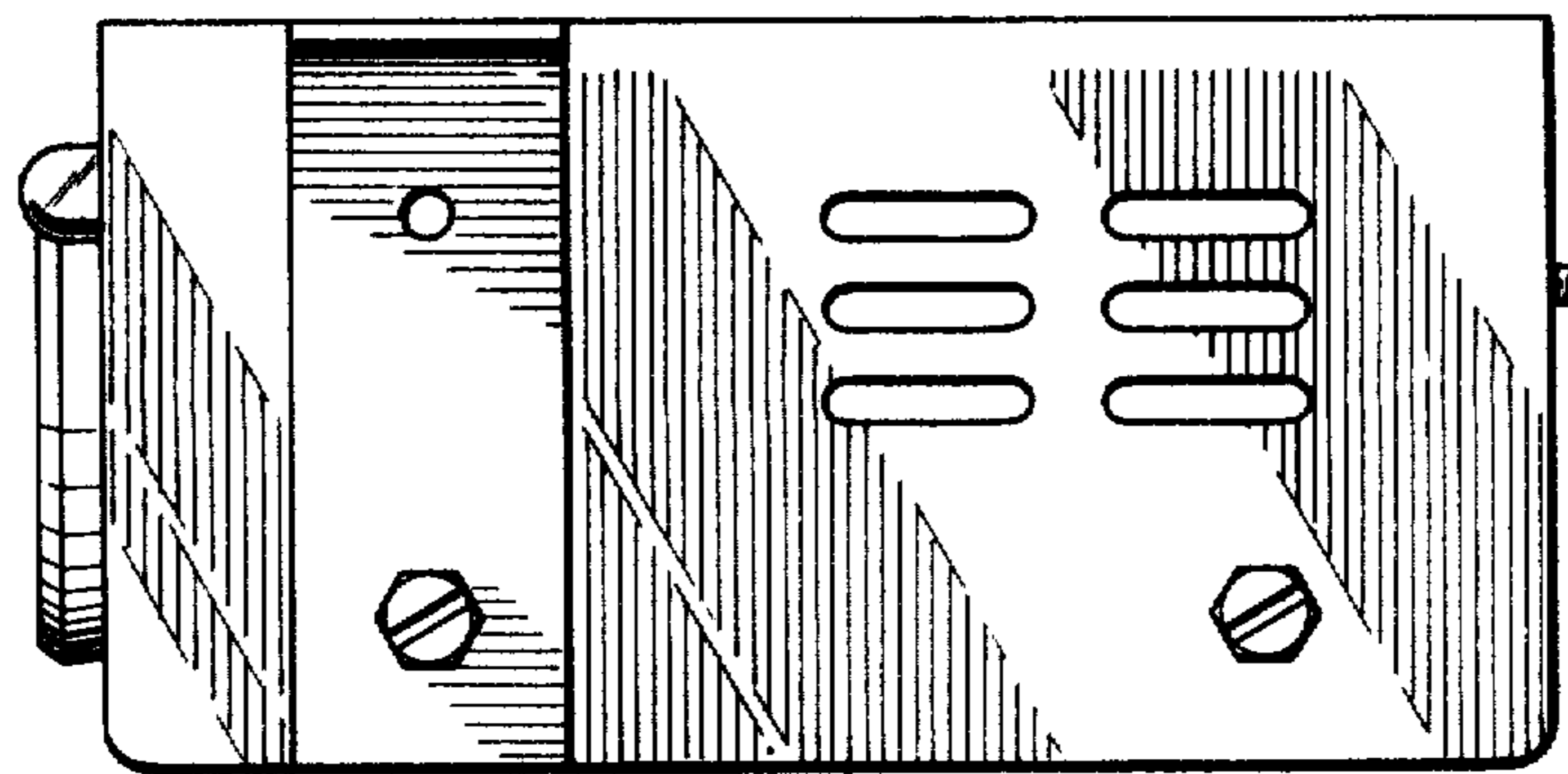

FIG. 6

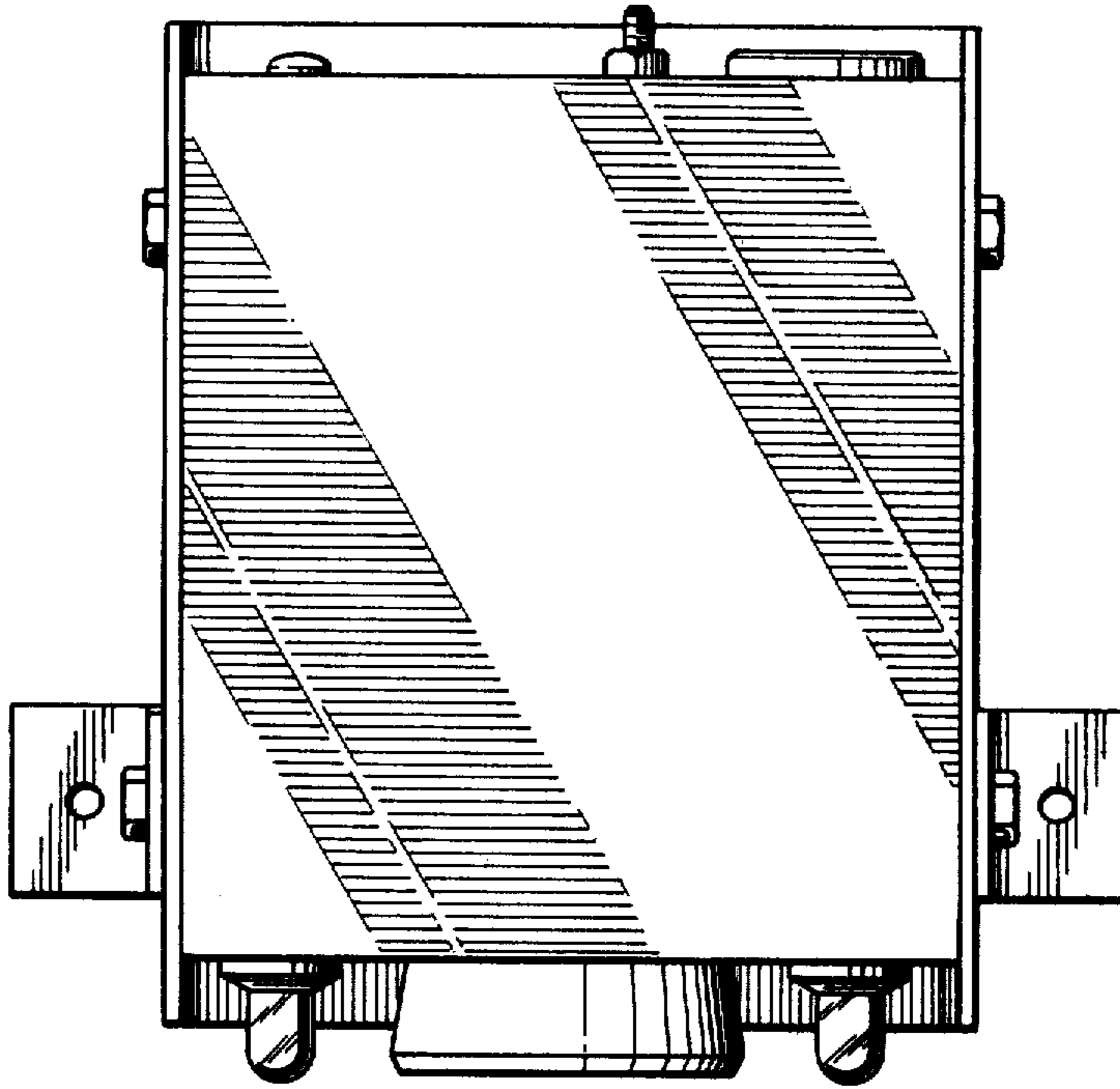

FIG. 4