

[54] TOWEL RAIL

[75] Inventor: Bruce R. Thompson, Tranmere, Australia

[73] Assignee: UPL Group Limited, Brisbane, Australia

[**] Term: 14 Years

[21] Appl. No.: 121,241

[22] Filed: Feb. 13, 1980

[51] Int. Cl. D23-02

[52] U.S. Cl. D6/99

[58] Field of Search D6/86-104; 108/29-31, 42, 152; 211/16, 87, 88, 105.1, 123, 124

[56] References Cited

U.S. PATENT DOCUMENTS

- D. 157,015 1/1950 Wheeler D6/99
- D. 238,919 2/1976 Vrignaud D6/99
- D. 254,461 3/1980 Tegner D6/99

Primary Examiner—B. J. Bullock
Attorney, Agent, or Firm—McDougall, Hersh & Scott

[57] CLAIM

The ornamental design for a towel rail, as shown.

DESCRIPTION

FIG. 1 is a perspective view of a towel rail showing my new design;

FIG. 2 is a top plan view thereof;

FIG. 3 is a bottom plan view thereof;

FIG. 4 is a front elevational view thereof;

FIG. 5 is a rear elevational view thereof;

FIG. 6 is an enlarged side elevational view taken from the left of FIG. 1, the side opposite being a mirror image thereof;

FIG. 7 is an enlarged sectional view taken in the direction of the arrows on line 7—7 of FIG. 5;

FIG. 8 is an enlarged sectional view taken in the direction of the arrows on line 8—8 of FIG. 5; and

FIG. 9 is an enlarged sectional view taken in the direction of the arrows on line 9—9 of FIG. 5.

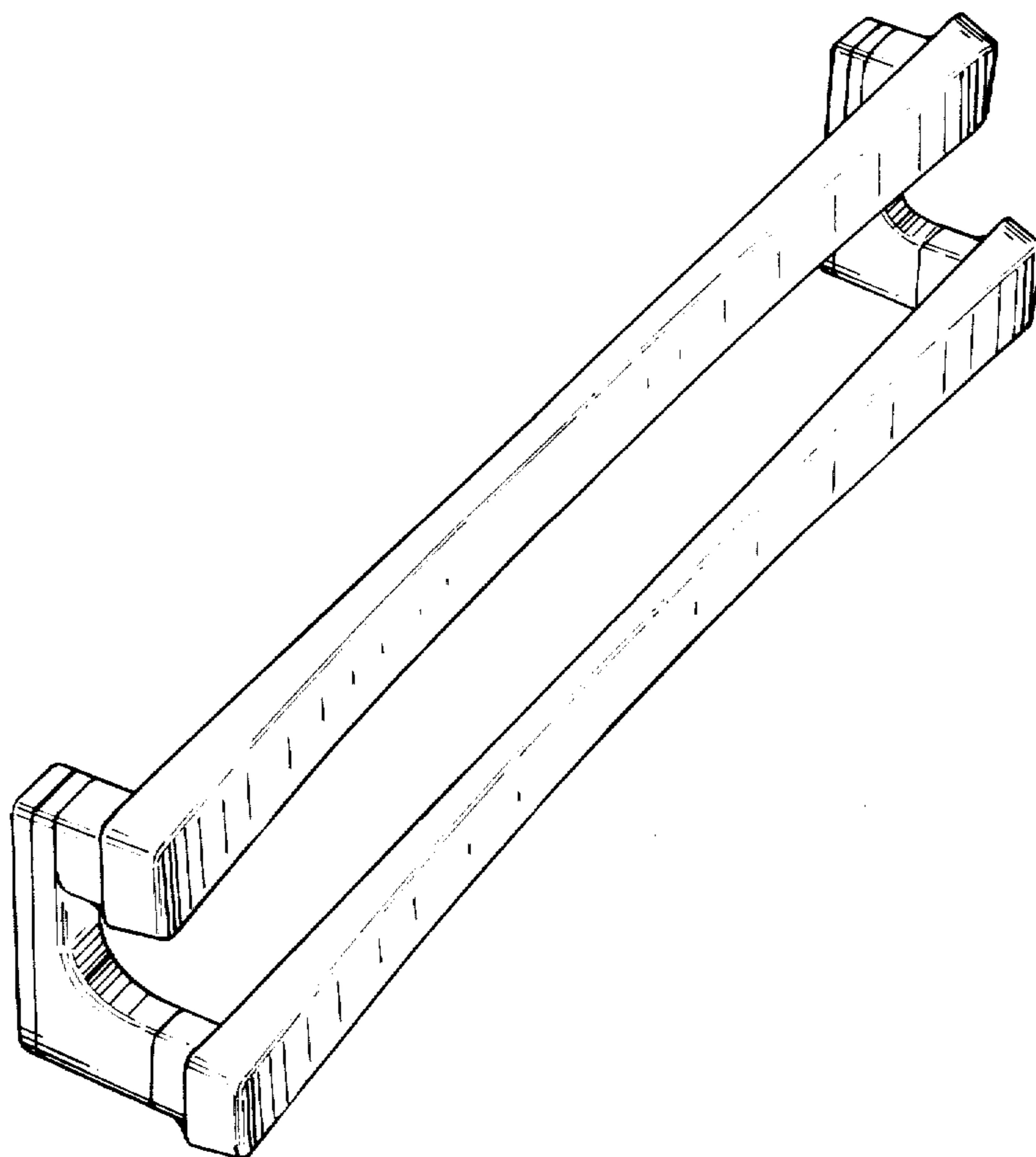

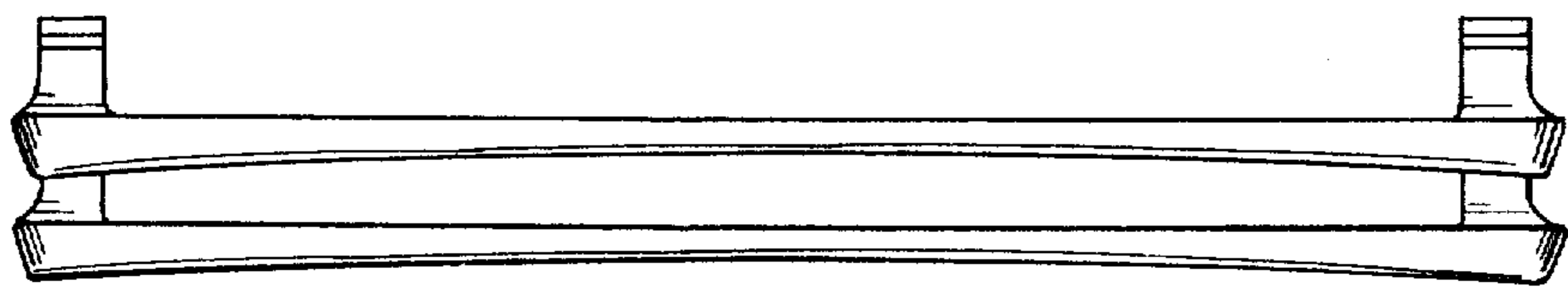
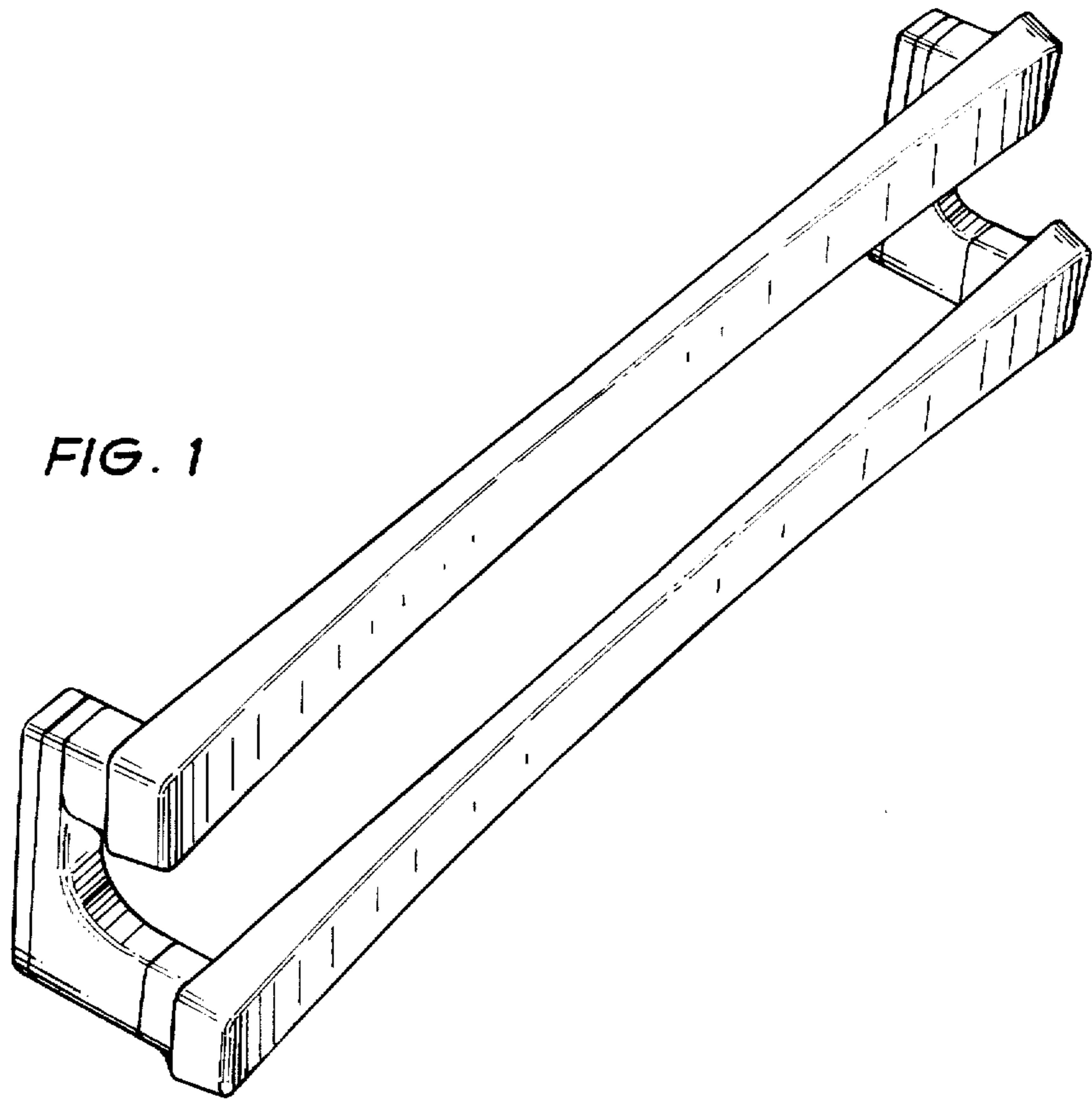

FIG. 2

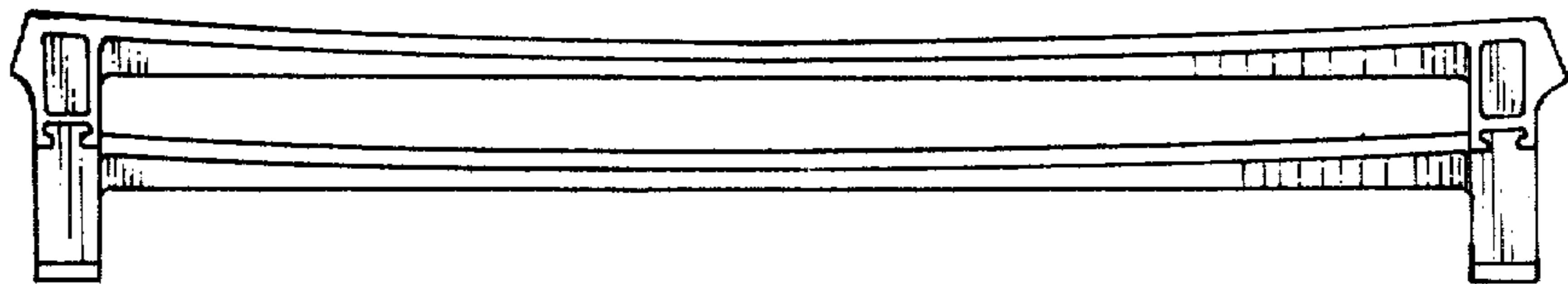

FIG. 3

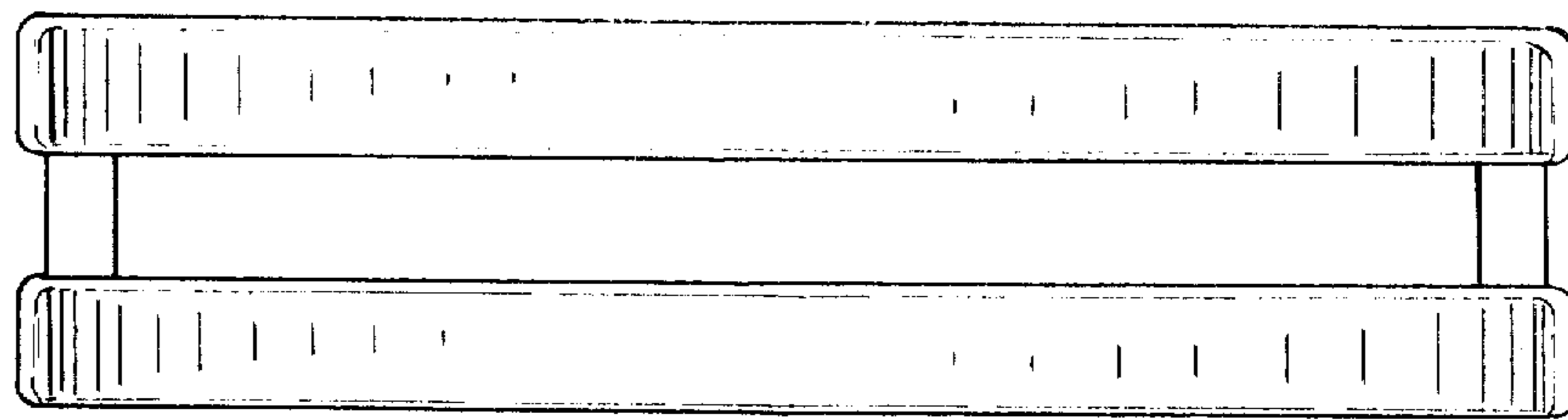

FIG. 4

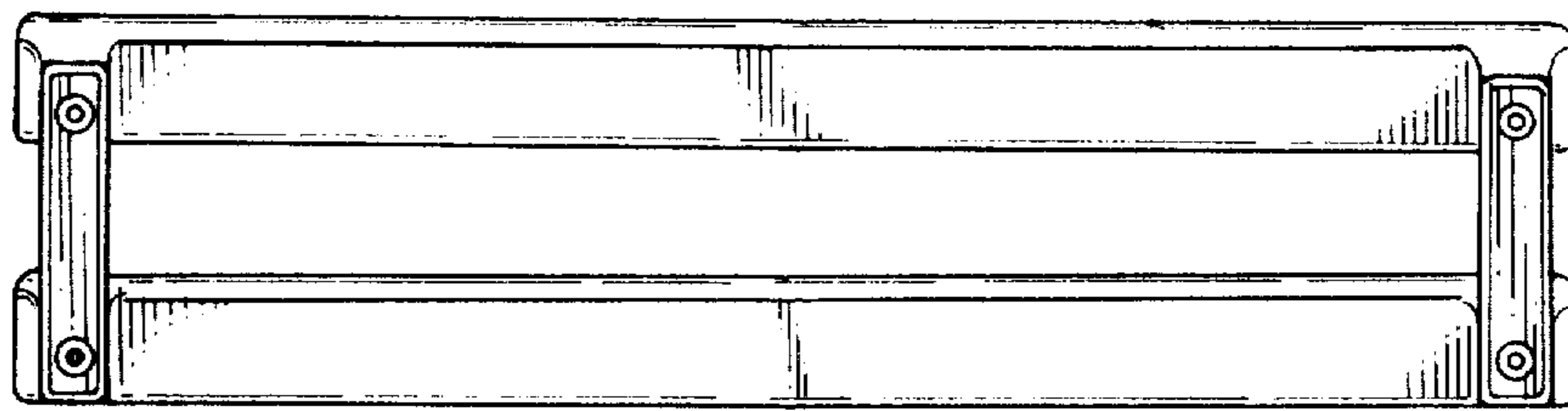
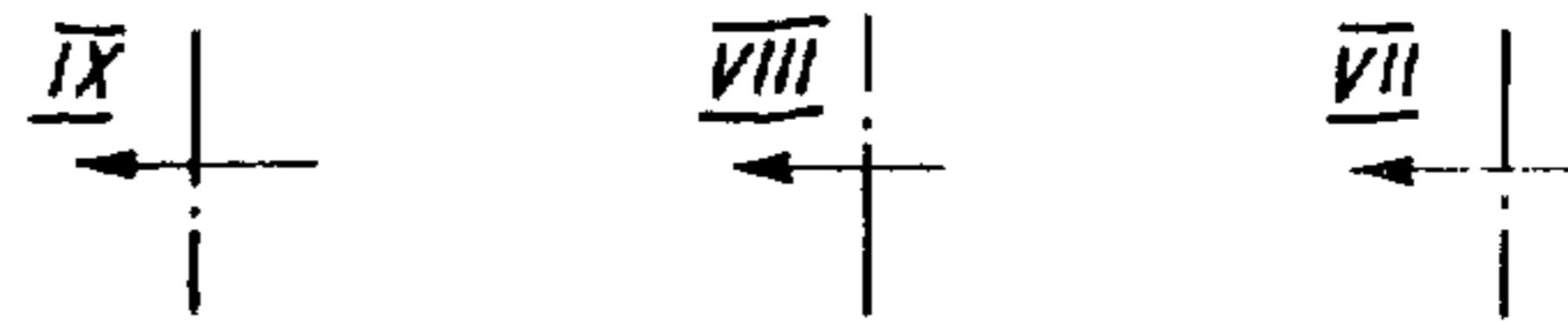

FIG. 5

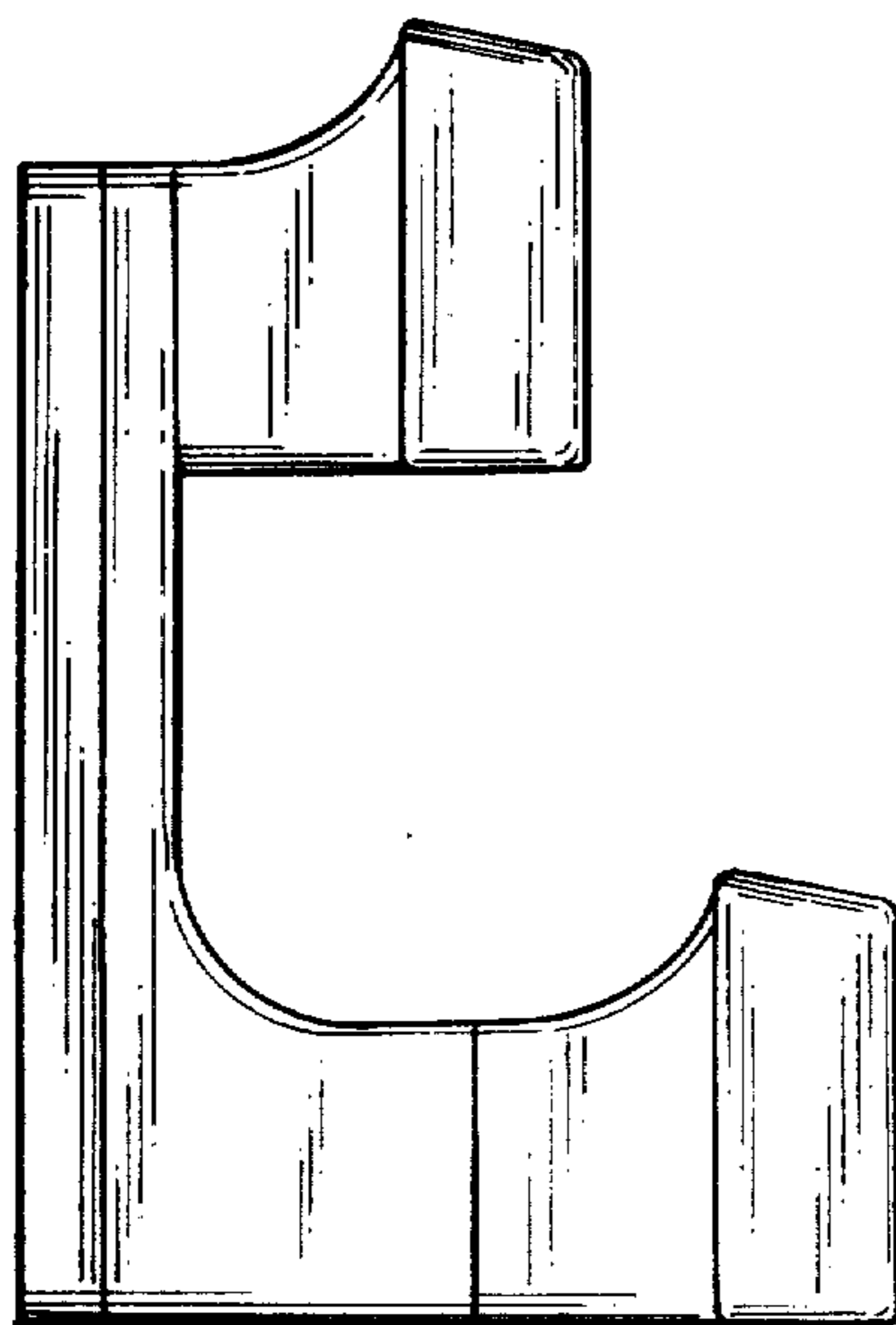

FIG. 6

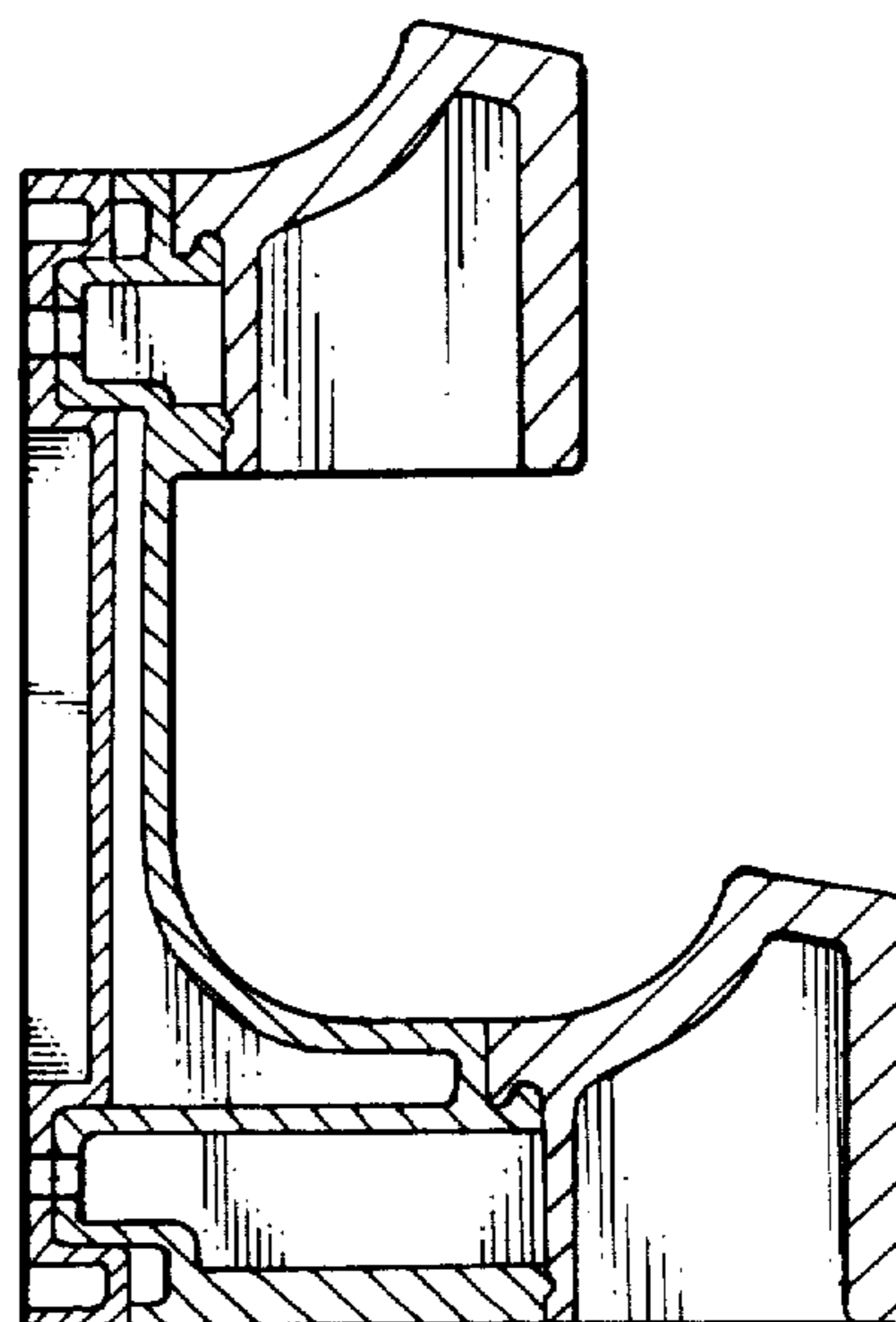

FIG. 7

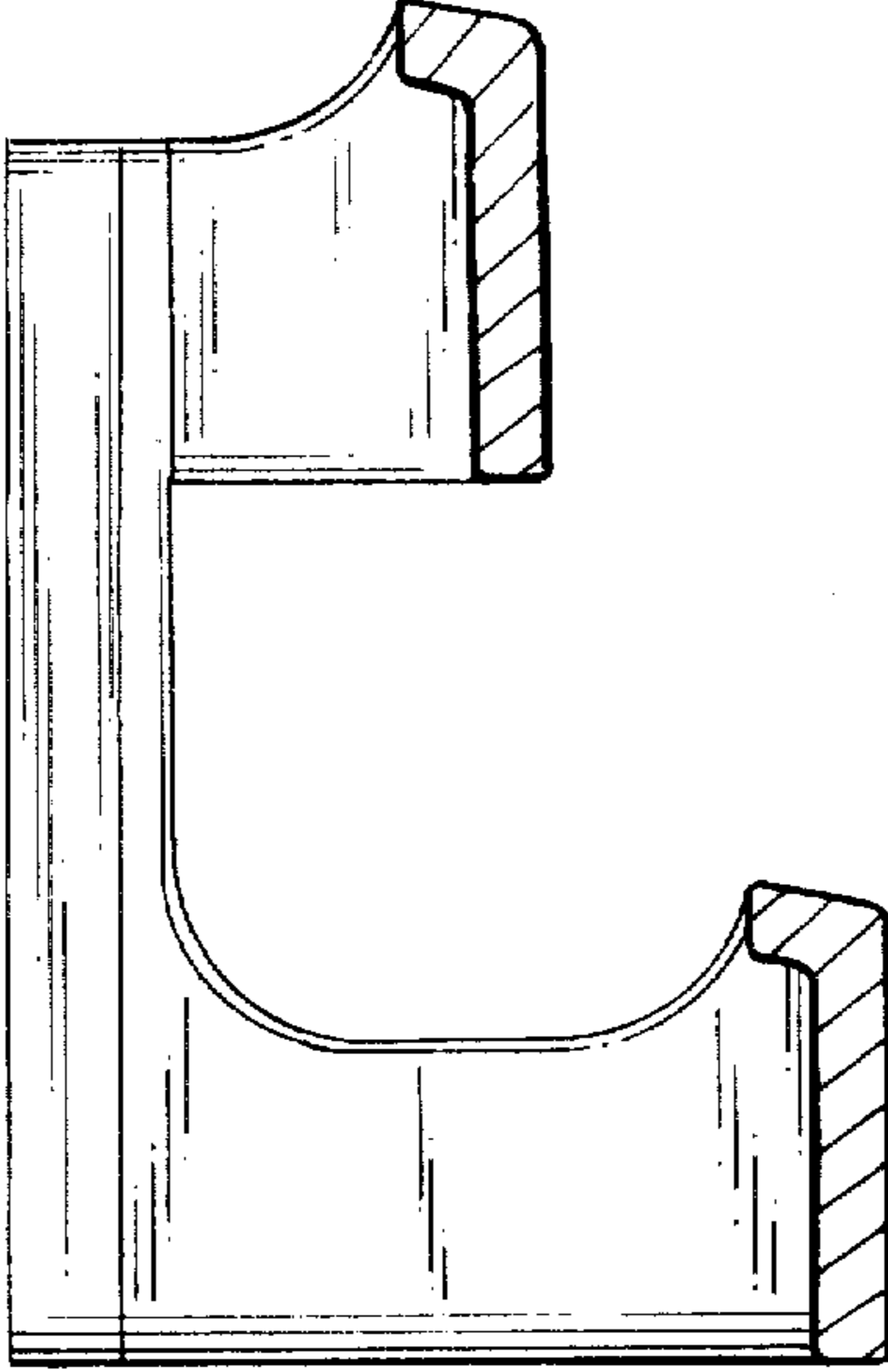

FIG. 8

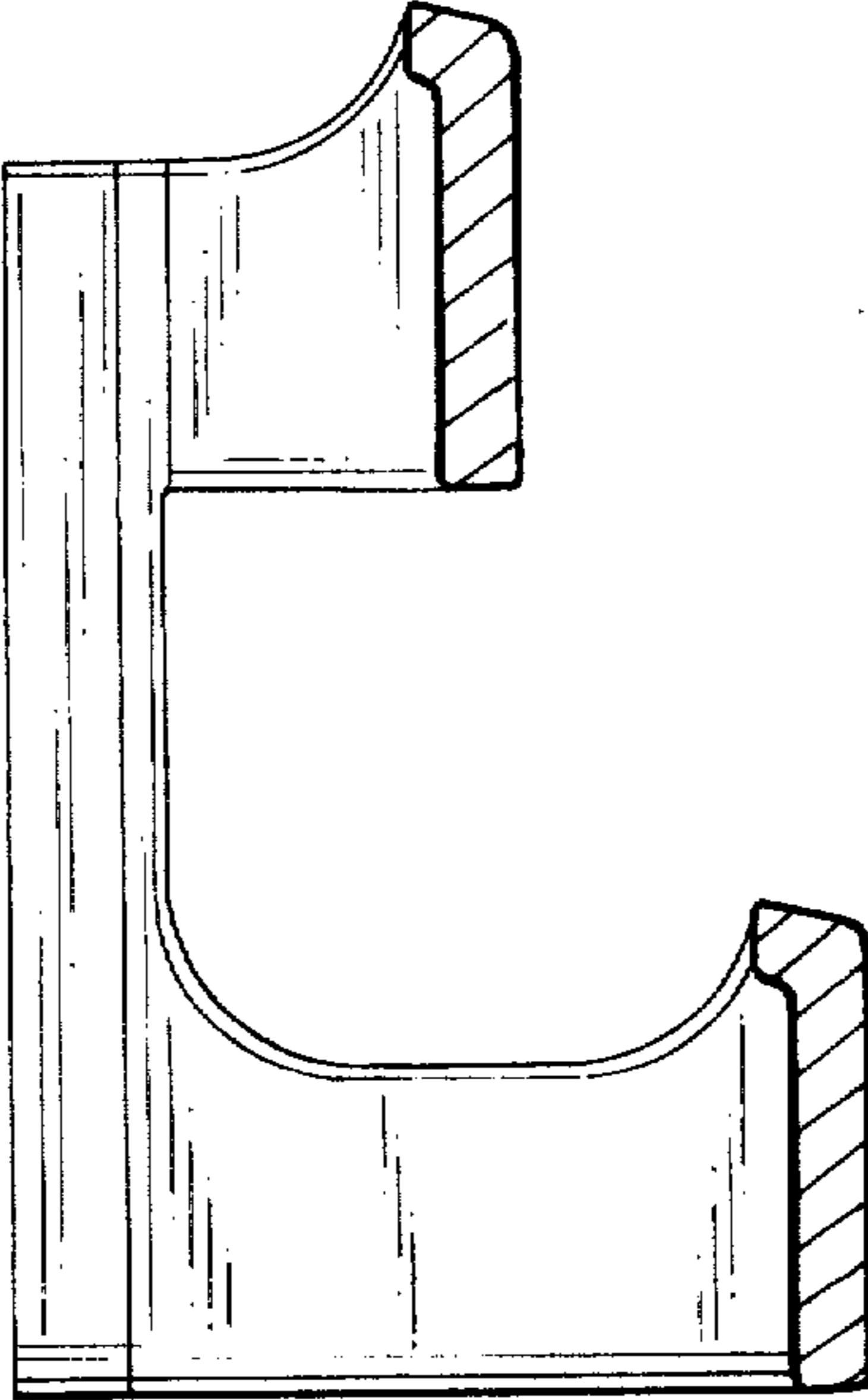

FIG. 9