

- [54] TOY TRAIN
- [75] Inventor: James F. Mariol, Cincinnati, Ohio
- [73] Assignee: Design Alliance, Inc., Cincinnati, Ohio
- [**] Term: 14 Years
- [21] Appl. No.: 118,430
- [22] Filed: Feb. 4, 1980
- [51] Int. Cl. D21-01
- [52] U.S. Cl. D21/129
- [58] Field of Search D21/76, 78, 129, 134, D21/136, 137; 46/216, 217, 218; 104/DIG. 1

3,407,533 10/1968 Hughes D21/129 X

OTHER PUBLICATIONS

Sears Christmas Catalogue, 1977, p. 483, toy locomotive in upper left.

Primary Examiner—Leland A. Sebastian
Attorney, Agent, or Firm—Wood, Herron & Evans

CLAIM

The ornamental design for a toy train, as shown and described.

DESCRIPTION

FIG. 1 is a perspective view of a toy train showing my new design.
 FIG. 2 is a side elevational view thereof, the other side being a mirror image;
 FIG. 3 is a front end elevational view thereof;
 FIG. 4 is a rear end elevational view thereof;
 FIG. 5 is a top plan view thereof; and,
 FIG. 6 is a bottom plan view thereof.

- [56] **References Cited**
- U.S. PATENT DOCUMENTS**
- D. 221,163 7/1971 Tong D21/129
- D. 257,734 12/1980 Rosenberg D21/129
- D. 258,164 2/1981 Burdock D21/129

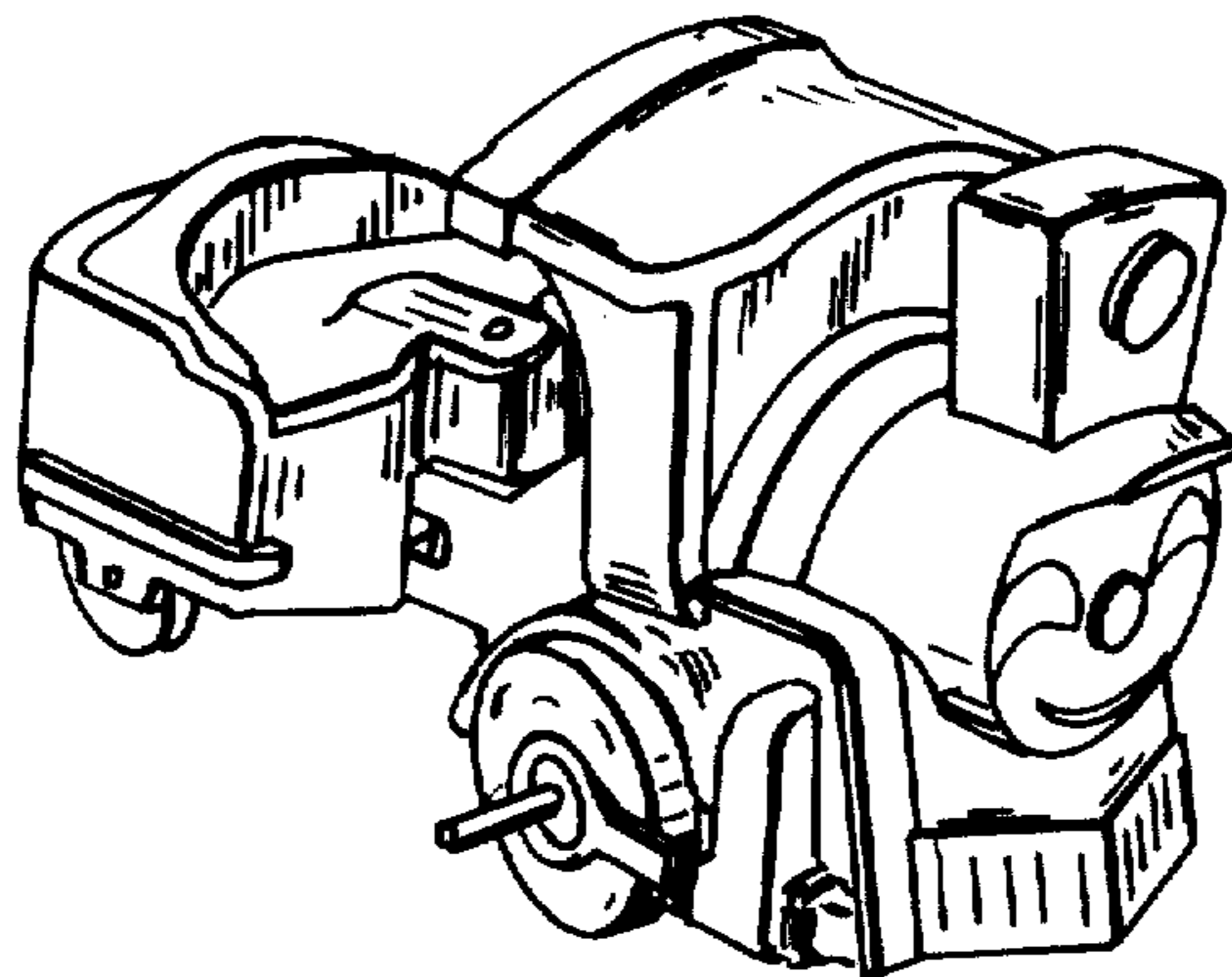

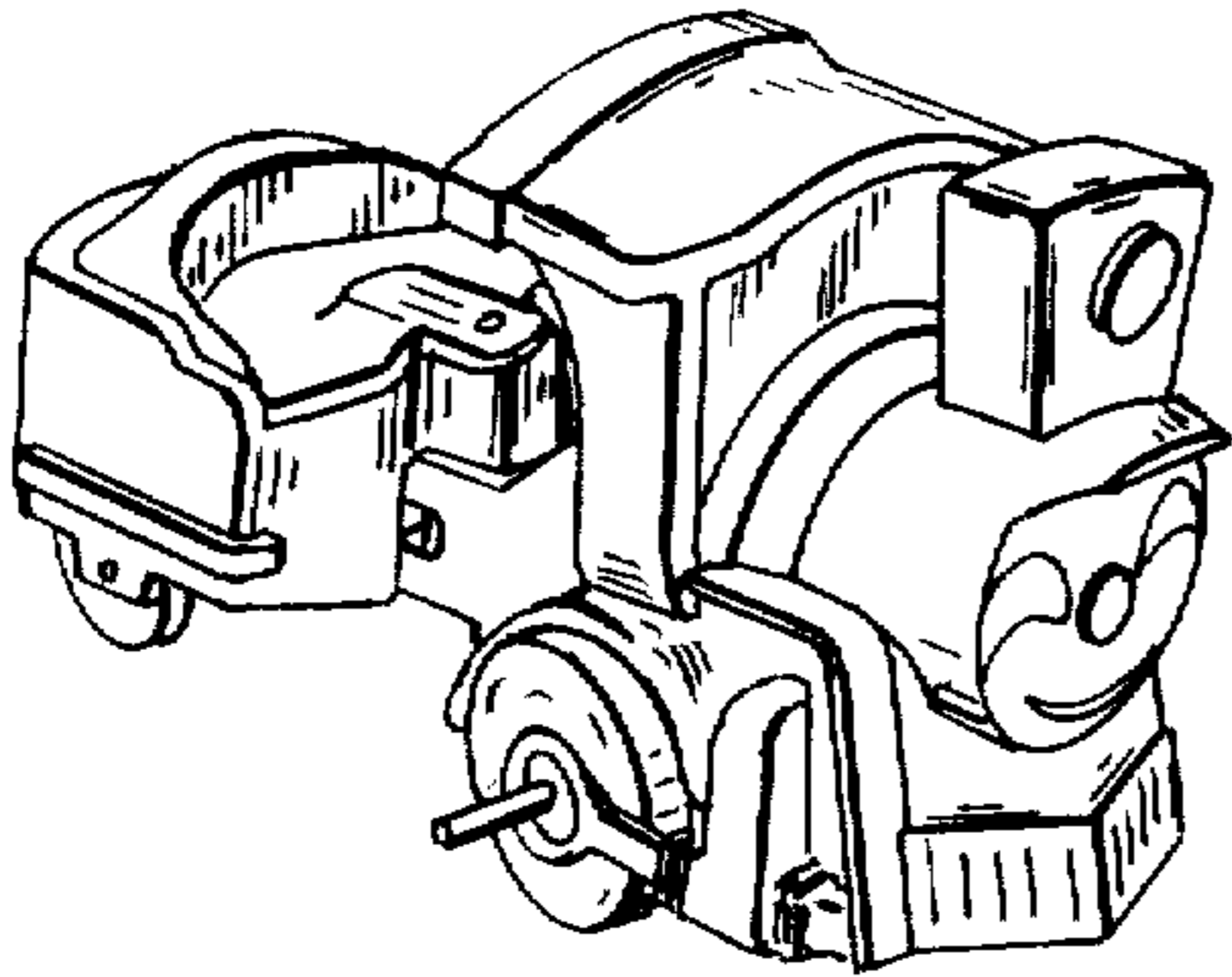

Fig. 1

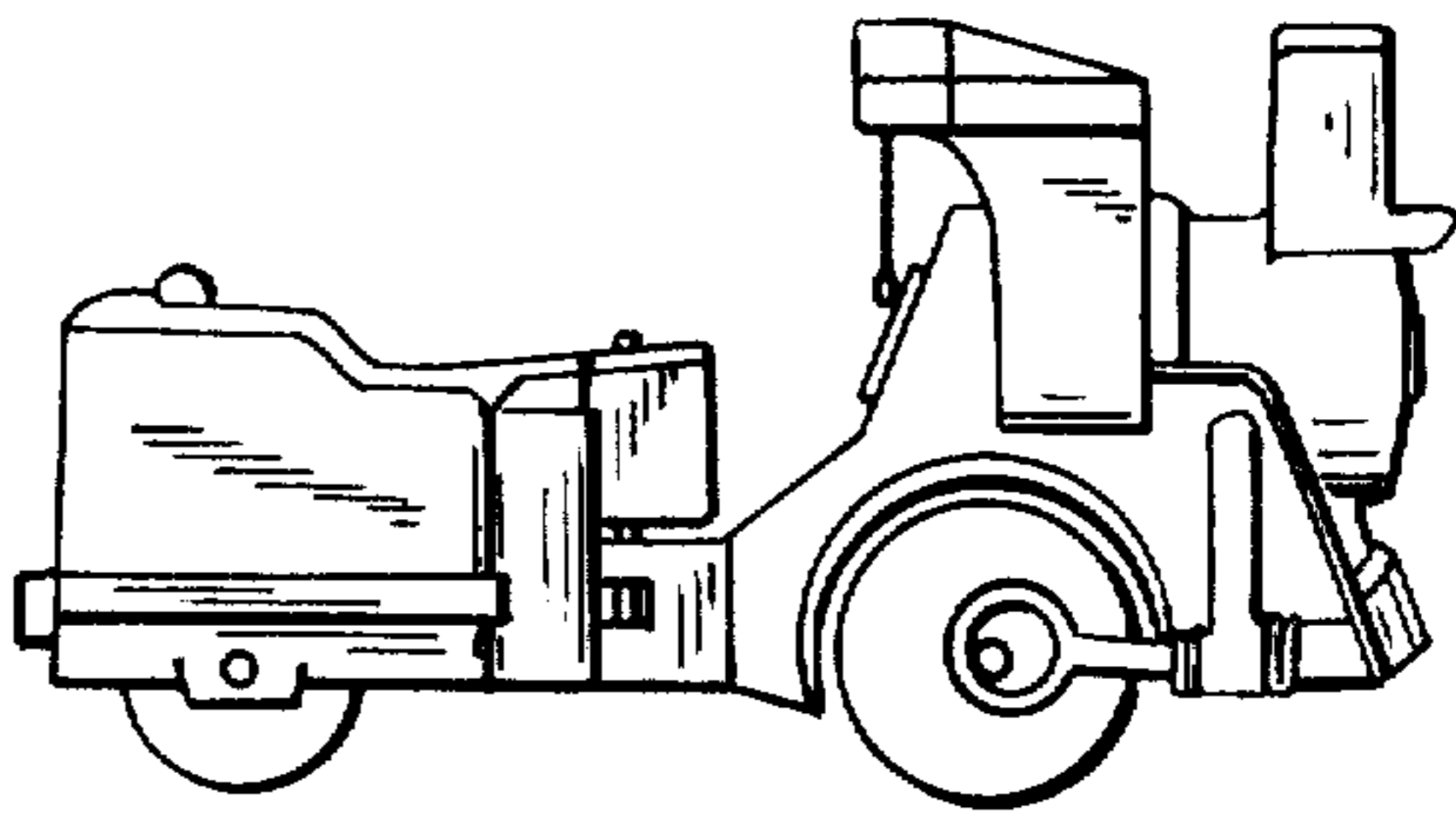

Fig. 2

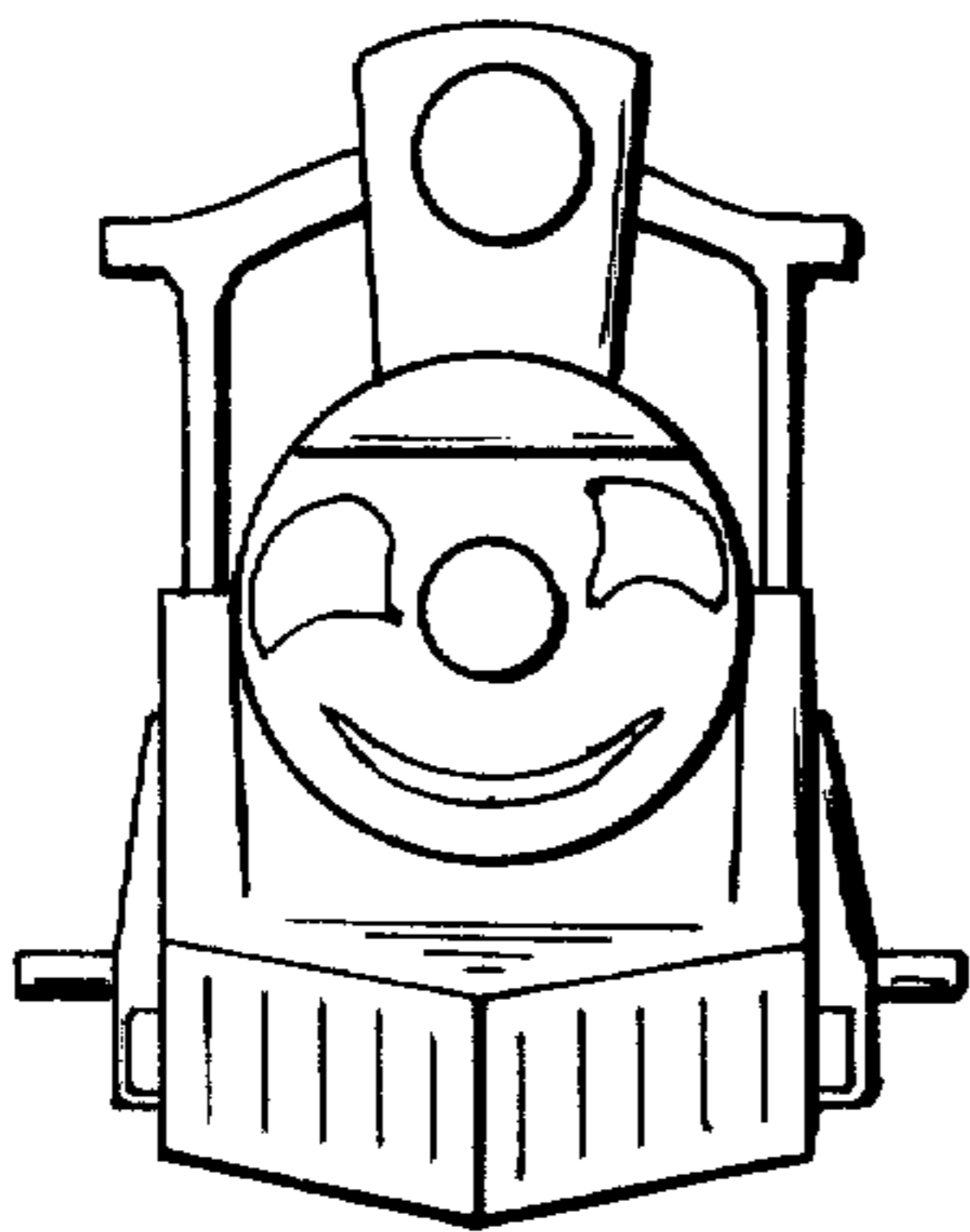

Fig. 3

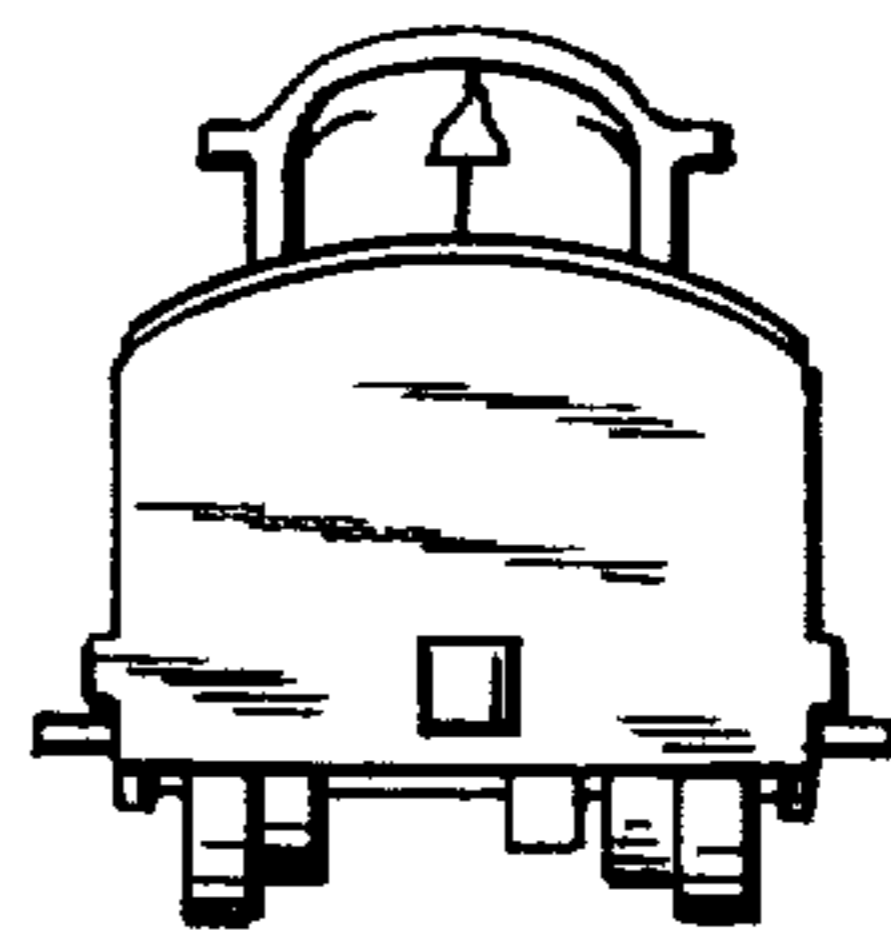

Fig. 4

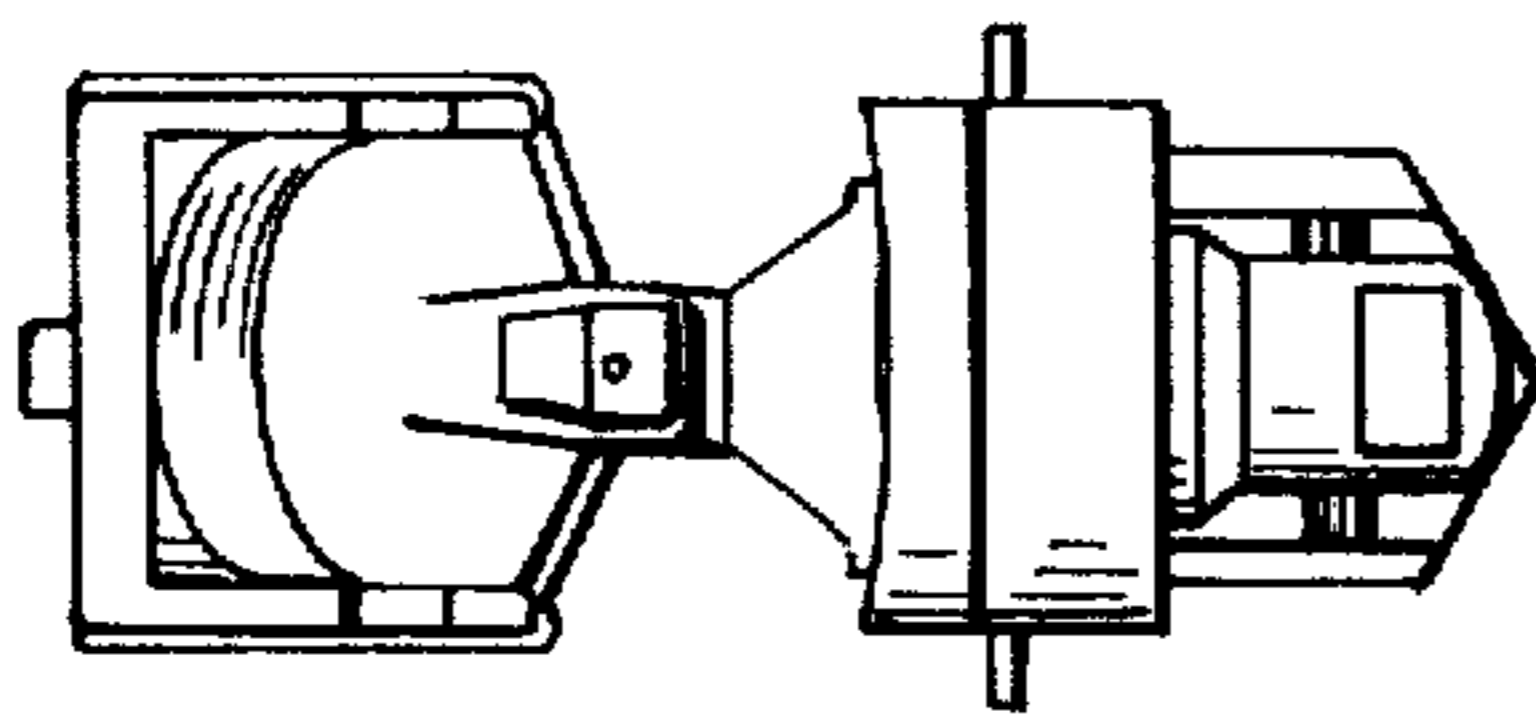

Fig. 5

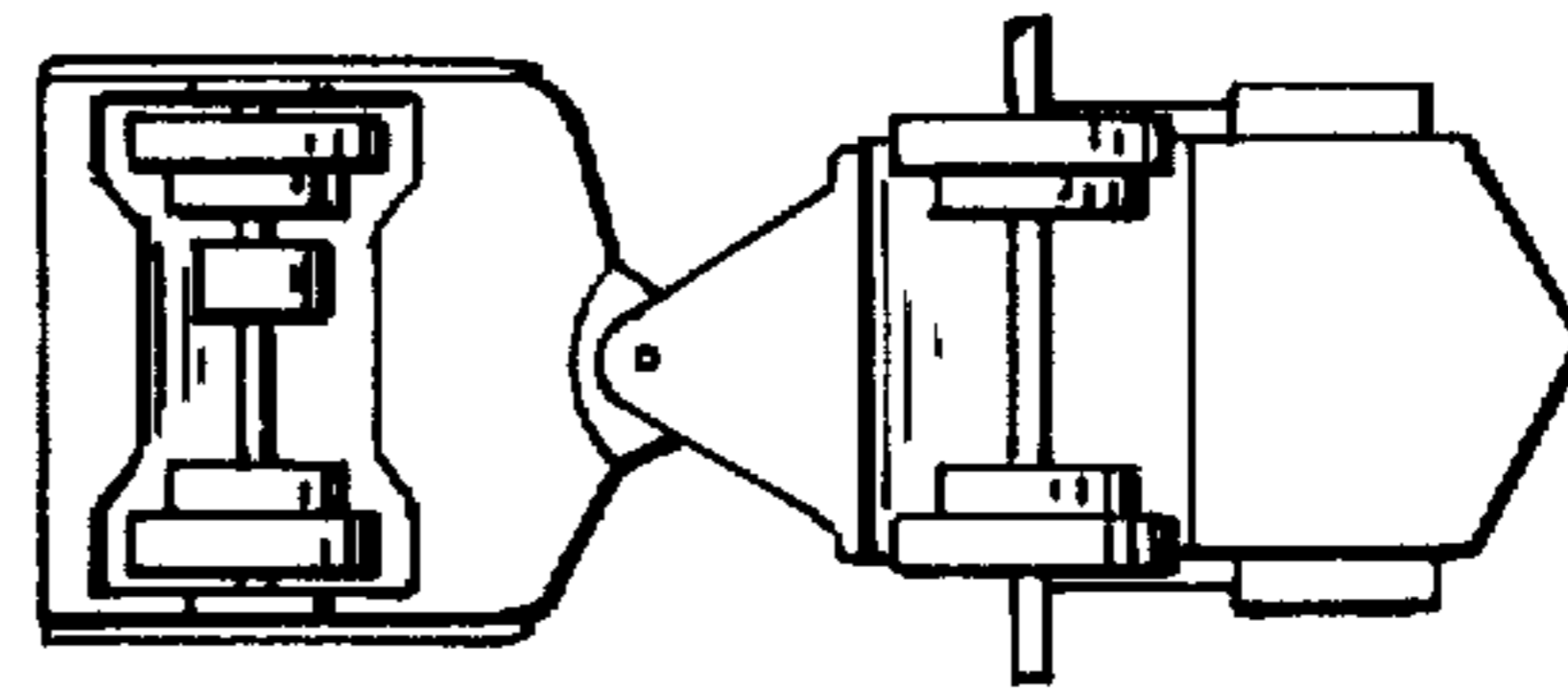

Fig. 6