

- [54] VAN
- [76] Inventor: **Darwin B. Cole**, 310 W. Richey,  
Houston, Tex. 77090
- [\*\*] Term: **14 Years**
- [21] Appl. No.: **92,749**
- [22] Filed: **Nov. 9, 1979**
- [51] Int. Cl. .... **D12-08**
- [52] U.S. Cl. .... **D12/99**
- [58] Field of Search ..... **D12/183, 99, 100;**  
**D25/52; 296/145, 178, 185**

- [56] **References Cited**
  - U.S. PATENT DOCUMENTS**
  - 3,730,580 5/1973 Page, Jr. .... **D12/99**
  - OTHER PUBLICATIONS**
  - R.V. Dealer, 10/78, p. 70, Travel Equipment Corp. van,  
bottom right side of page.
  - R.V. Dealer, 10/78, p. 70, Omnifac's van, bottom center  
of page.

J. C. Whitney Catalog No. 365D, ©1977, p. 26, bubble  
Chevrolet window K, top right side of page.  
*Primary Examiner*—James M. Gandy  
*Attorney, Agent, or Firm*—Gunn, Lee & Jackson

[57] **CLAIM**  
The ornamental design for a van, as shown and de-  
scribed.

**DESCRIPTION**  
FIG. 1 is a side elevational view of a van showing my  
new design;  
FIG. 2 is an end elevational view thereof;  
FIG. 3 is a top plan view thereof;  
FIG. 4 is a side elevational view thereof as seen from  
the side opposite the view shown in FIG. 1;  
FIG. 5 is a front elevational view thereof;  
FIG. 6 is an enlarged fragmentary elevational view  
showing the lower rear portion of the side window and  
rear side panel of the van in detail; and  
FIG. 7 is an enlarged fragmentary elevational view  
showing the lower rear portion of the opposite side  
window and rear side panel of the van in detail.  
The characteristic feature of my design resides in the  
horizontally elongated windows along the sides of the  
van.

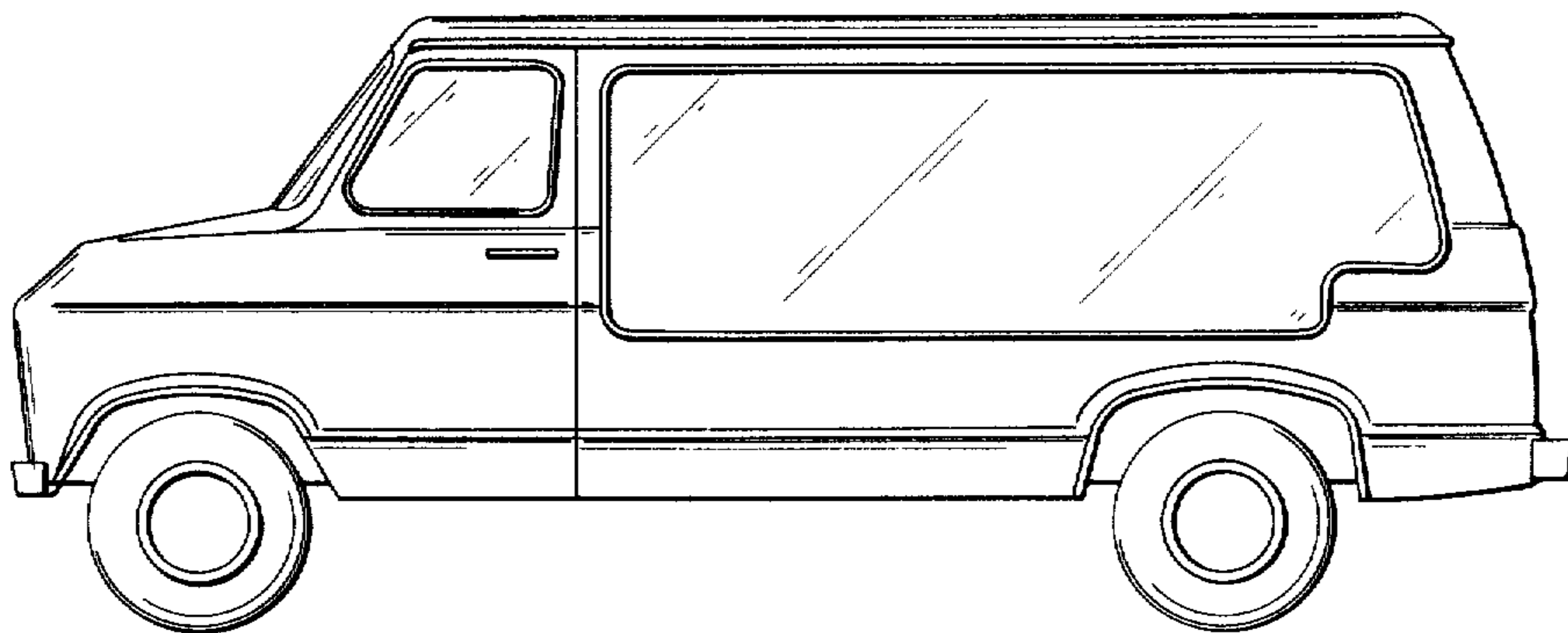

FIG. 1

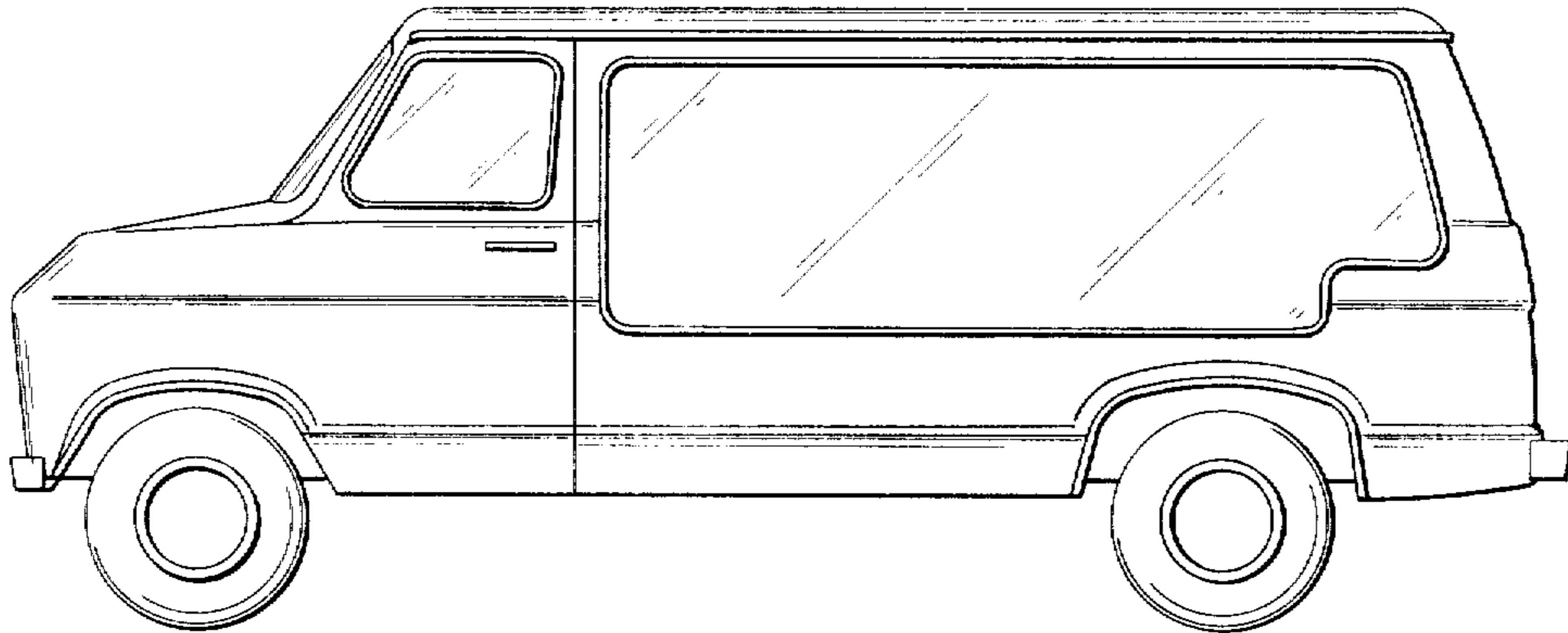

FIG. 2

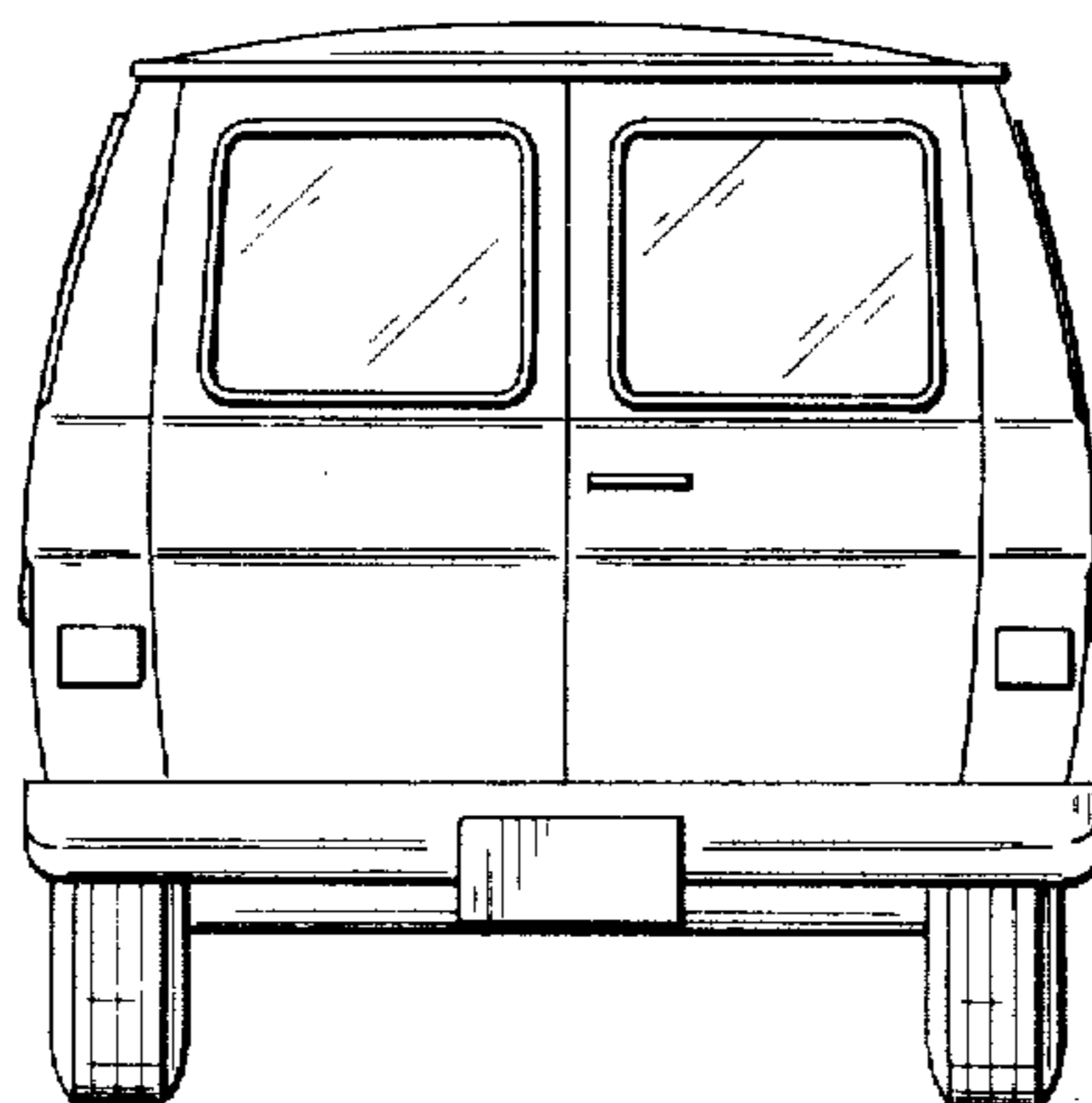
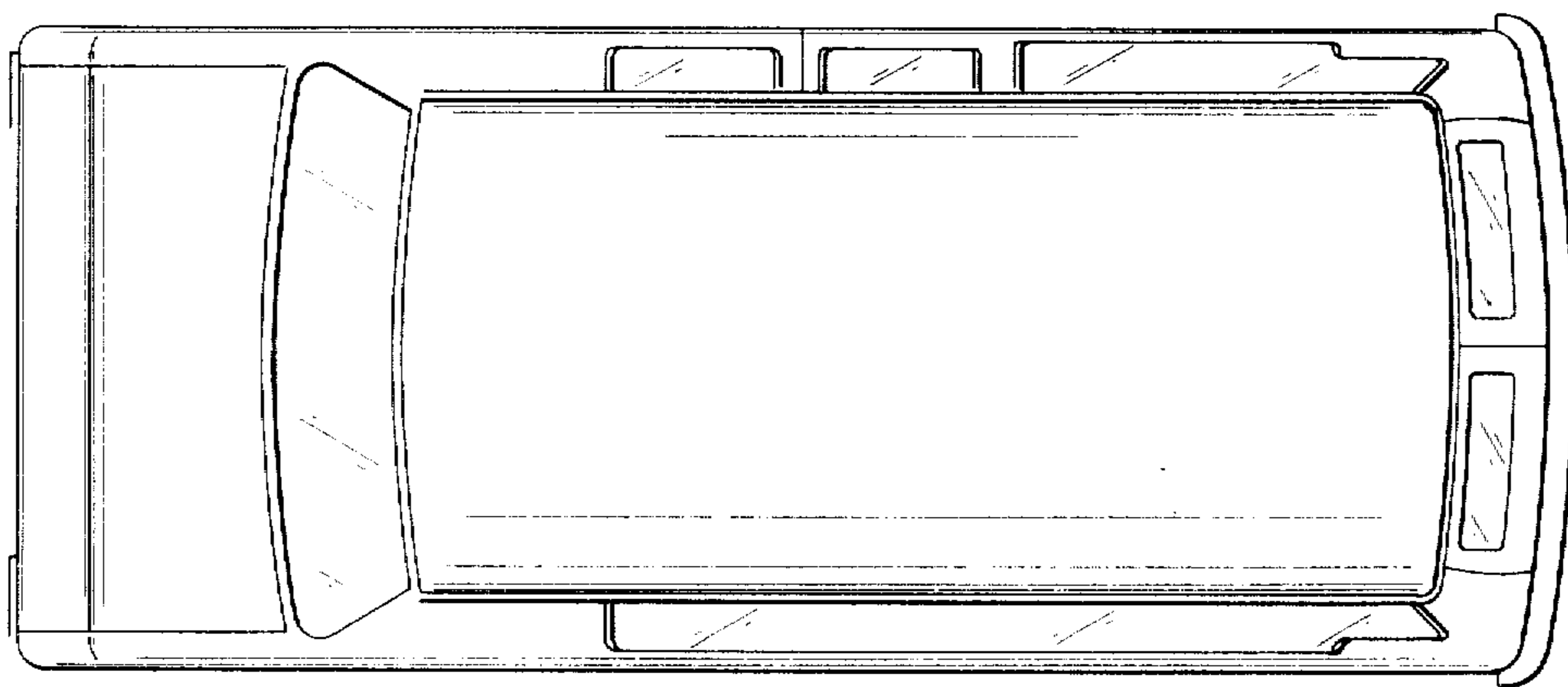

FIG. 3



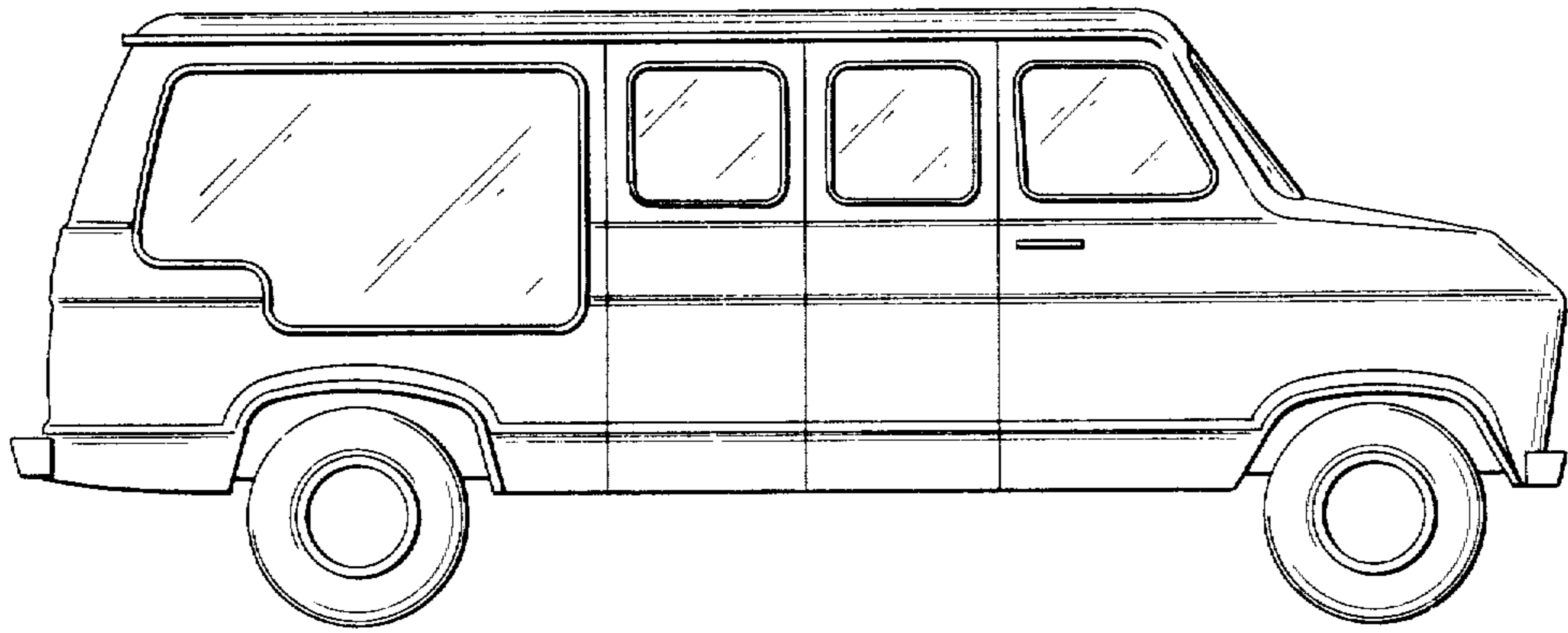
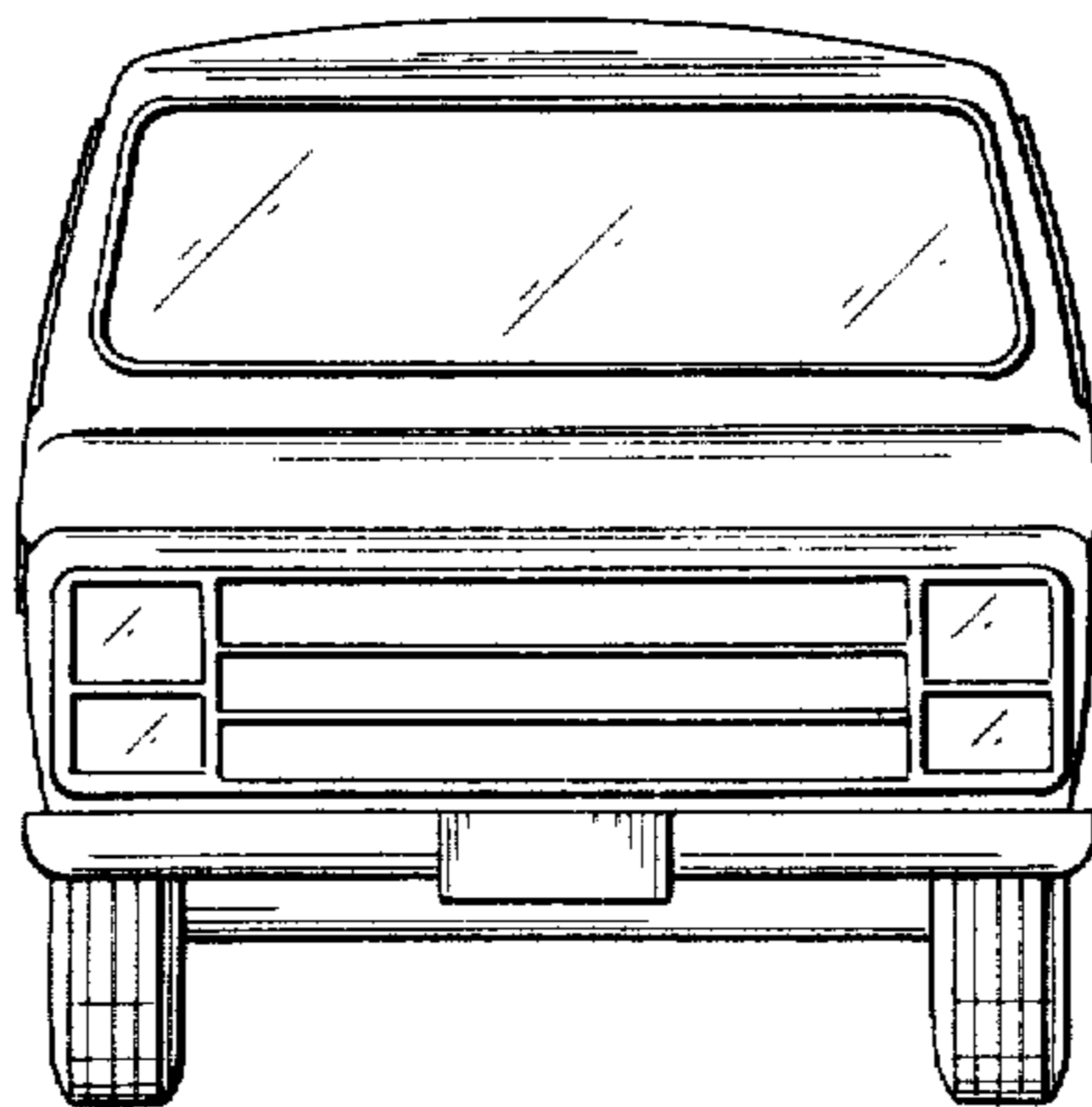

FIG. 4

FIG. 5



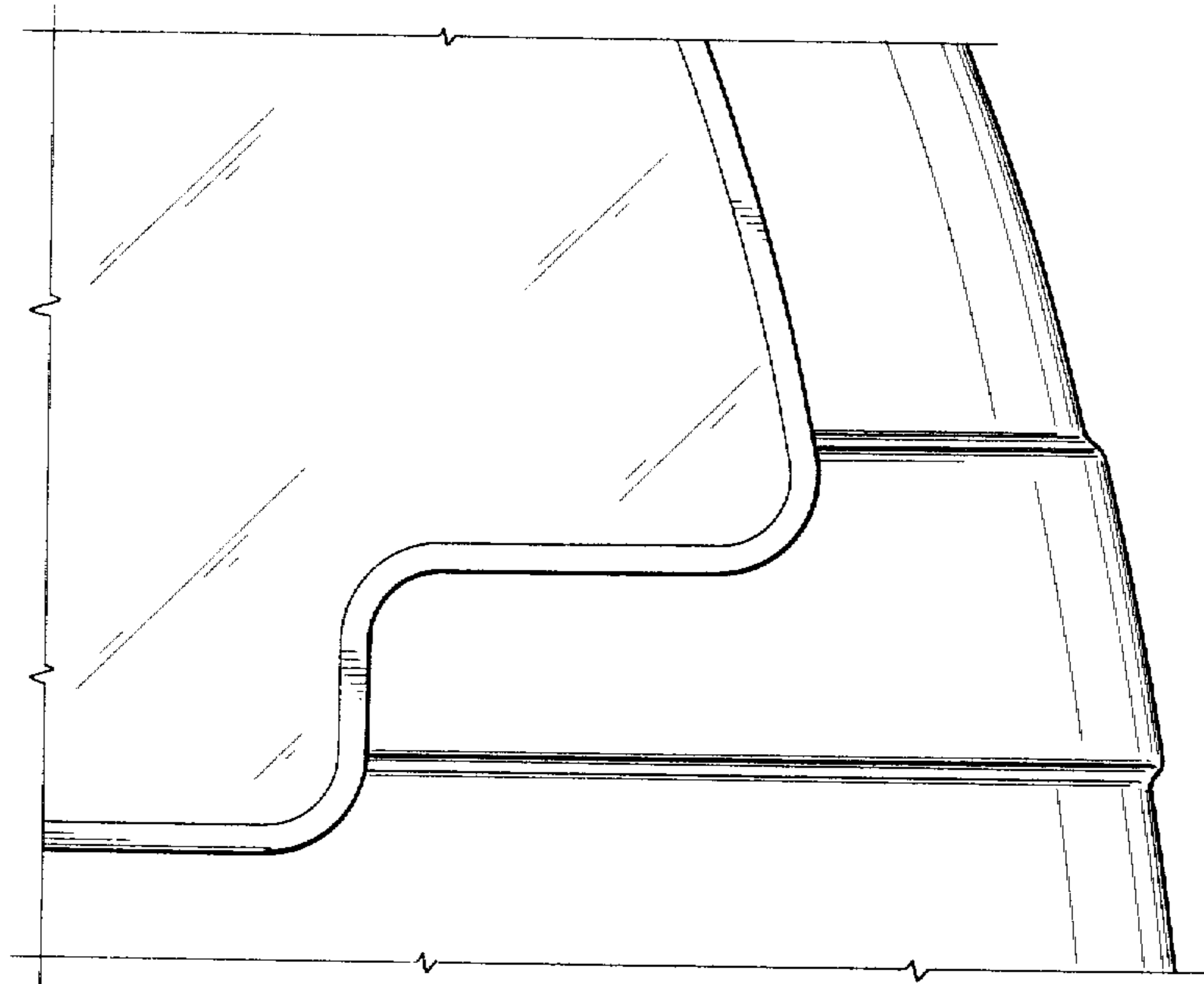

FIG. 6

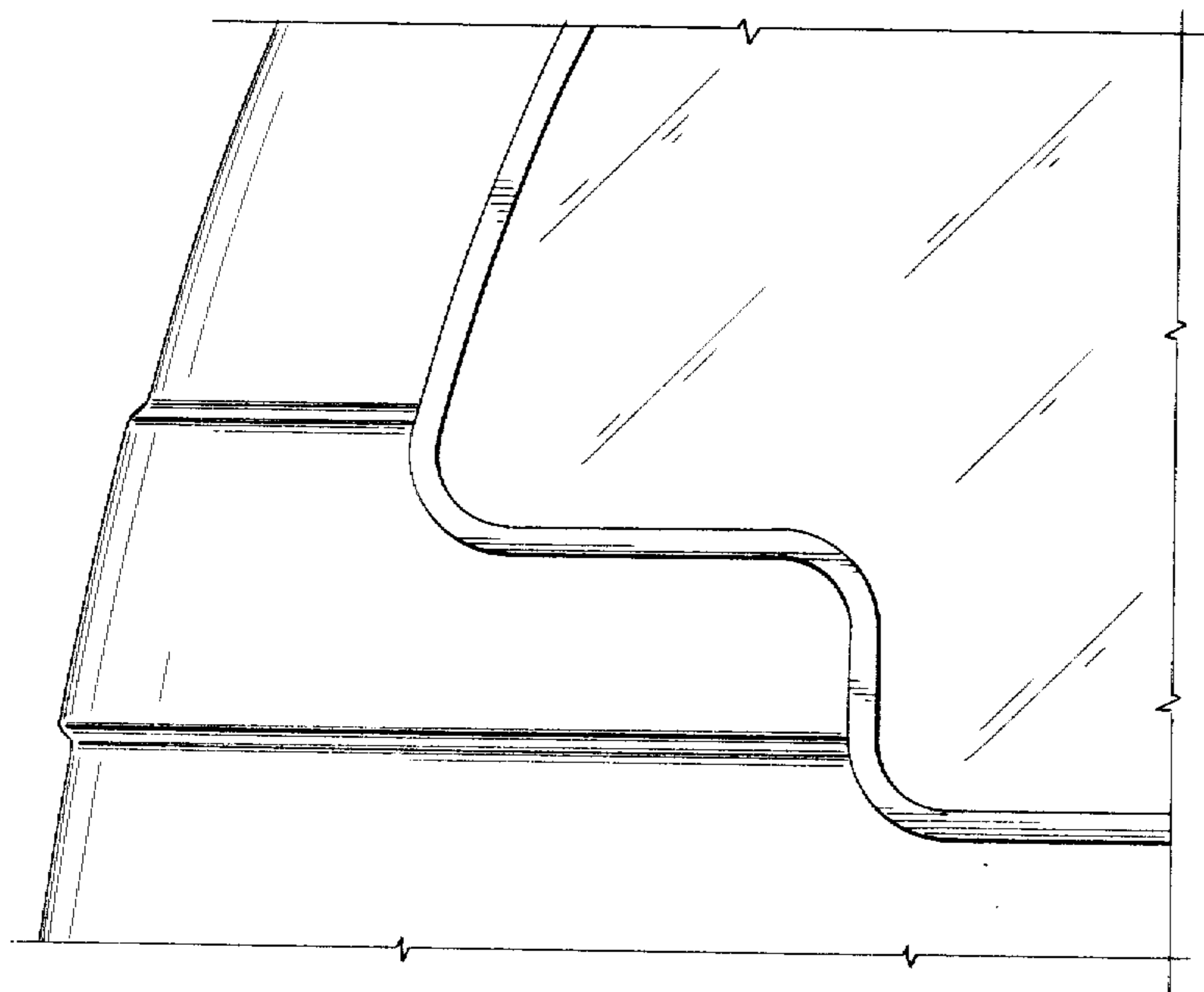

FIG. 7