

[54] TOY VEHICLE

[75] Inventors: **Shinroku Nakao**, Yokohama;  
**Yoshiyasu Ishii**; **Yukio Ishige**, both of  
Tokyo, all of Japan

[73] Assignee: **Combi Co., Ltd.**, Tokyo, Japan

[\*\*] Term: **14 Years**

[21] Appl. No.: **110,503**

[22] Filed: **Jan. 8, 1980**

[30] Foreign Application Priority Data

Jul. 13, 1979 [JP] Japan ..... 54-29280

[51] Int. Cl. .... **D21-01**

[52] U.S. Cl. .... **D21/78**

[58] Field of Search ..... D21/76, 78, 81, 128,  
D21/134, 135, 136, 137; 46/201, 204, 206, 210,  
221, 222, 223; D12/112-113, 107-108;  
280/1.11 R, 1.191, 1.202, 1.208, 1.173, 87.01,  
87.02

[56] References Cited

U.S. PATENT DOCUMENTS

- D. 213,511 3/1969 Moribe ..... D21/78
- D. 222,755 12/1971 Michael ..... D21/78
- D. 239,127 3/1976 Powers ..... D21/136
- D. 252,653 8/1979 Nakao et al. .... D21/78
- D. 253,710 12/1979 Nakao et al. .... D21/78

*Primary Examiner*—Charles A. Rademaker  
*Attorney, Agent, or Firm*—Sughrue, Mion, Zinn,  
Macpeak and Seas

[57] CLAIM

The ornamental design for a toy vehicle, as shown.

DESCRIPTION

FIG. 1 is a front, top and right side perspective view of a toy vehicle showing our new design; FIG. 2 is a right side perspective view thereof; FIG. 3 is a left side perspective view thereof; FIG. 4 is a front perspective view thereof; FIG. 5 is a rear perspective view thereof; FIG. 6 is a top plan view thereof; and FIG. 7 is a bottom plan view thereof.

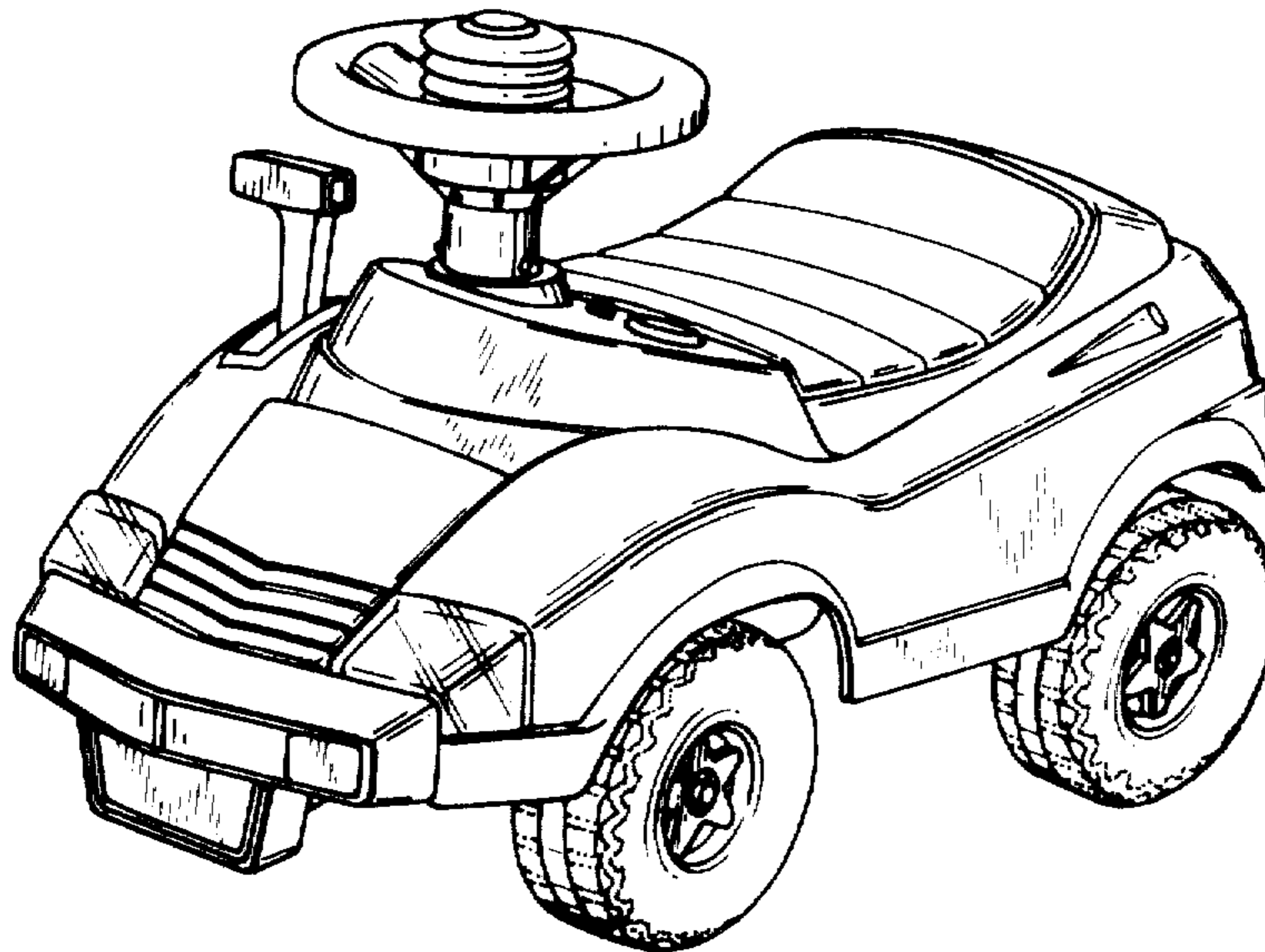

*FIG. 1*

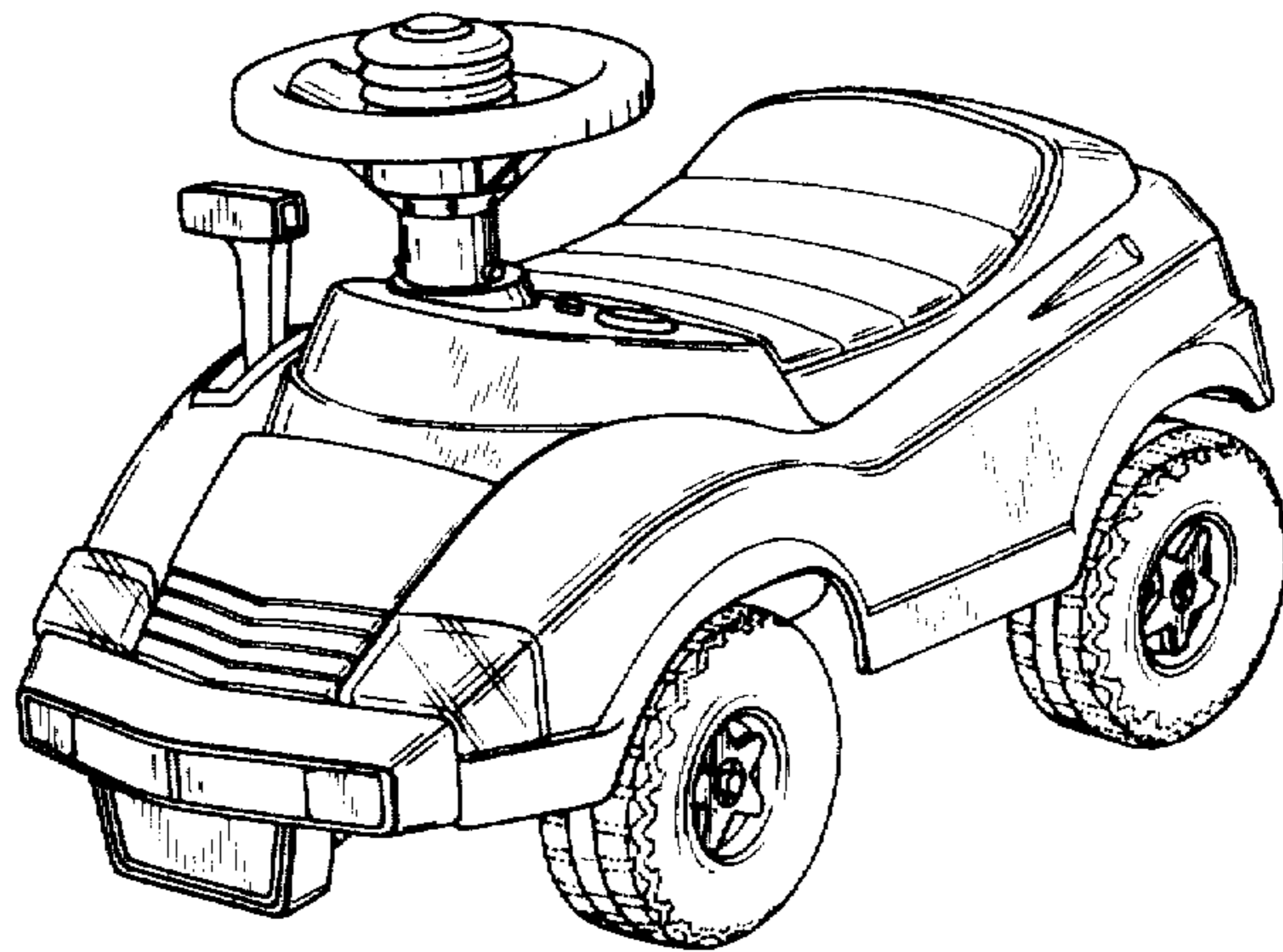

*FIG. 2*

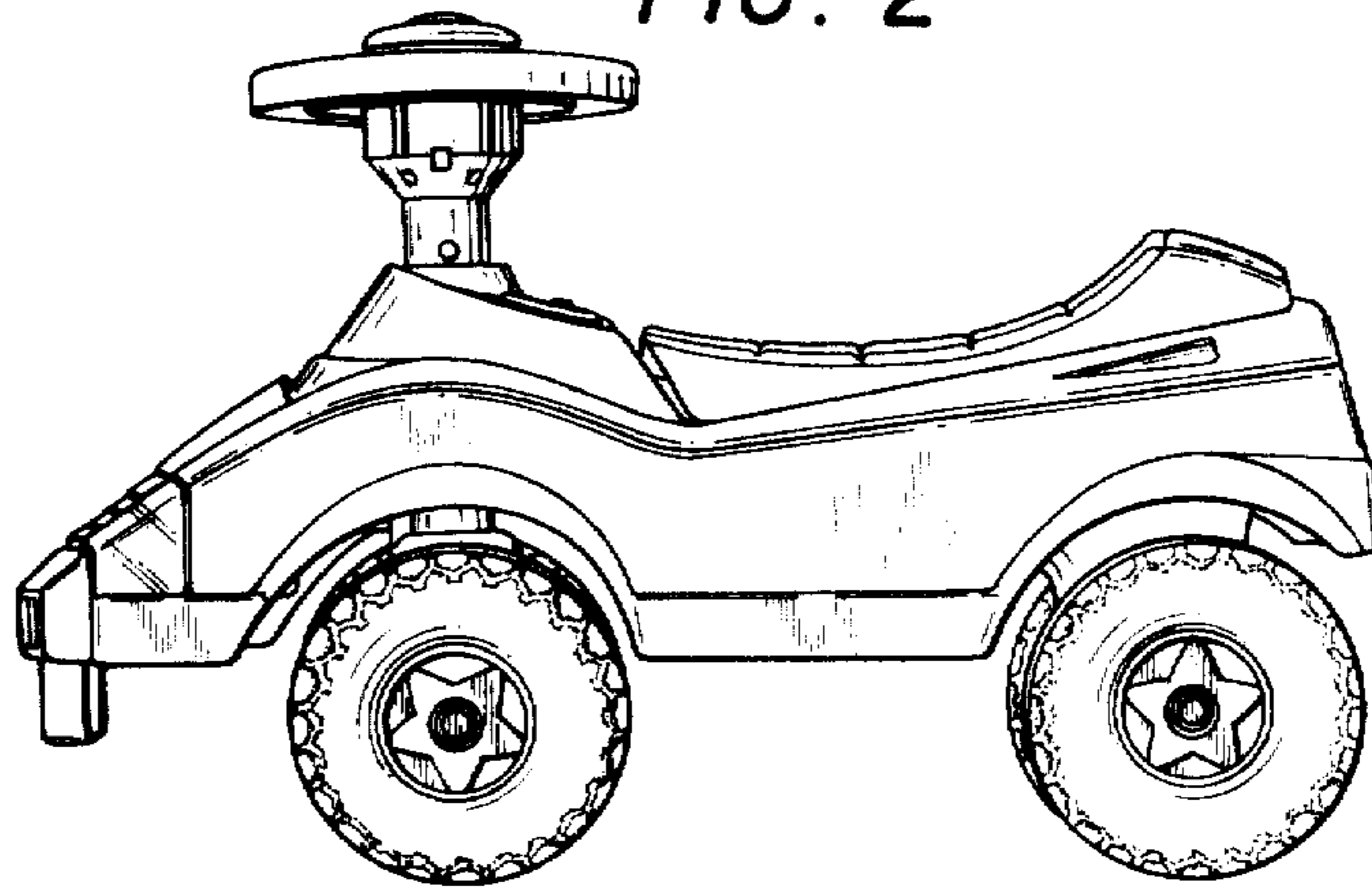

*FIG. 3*

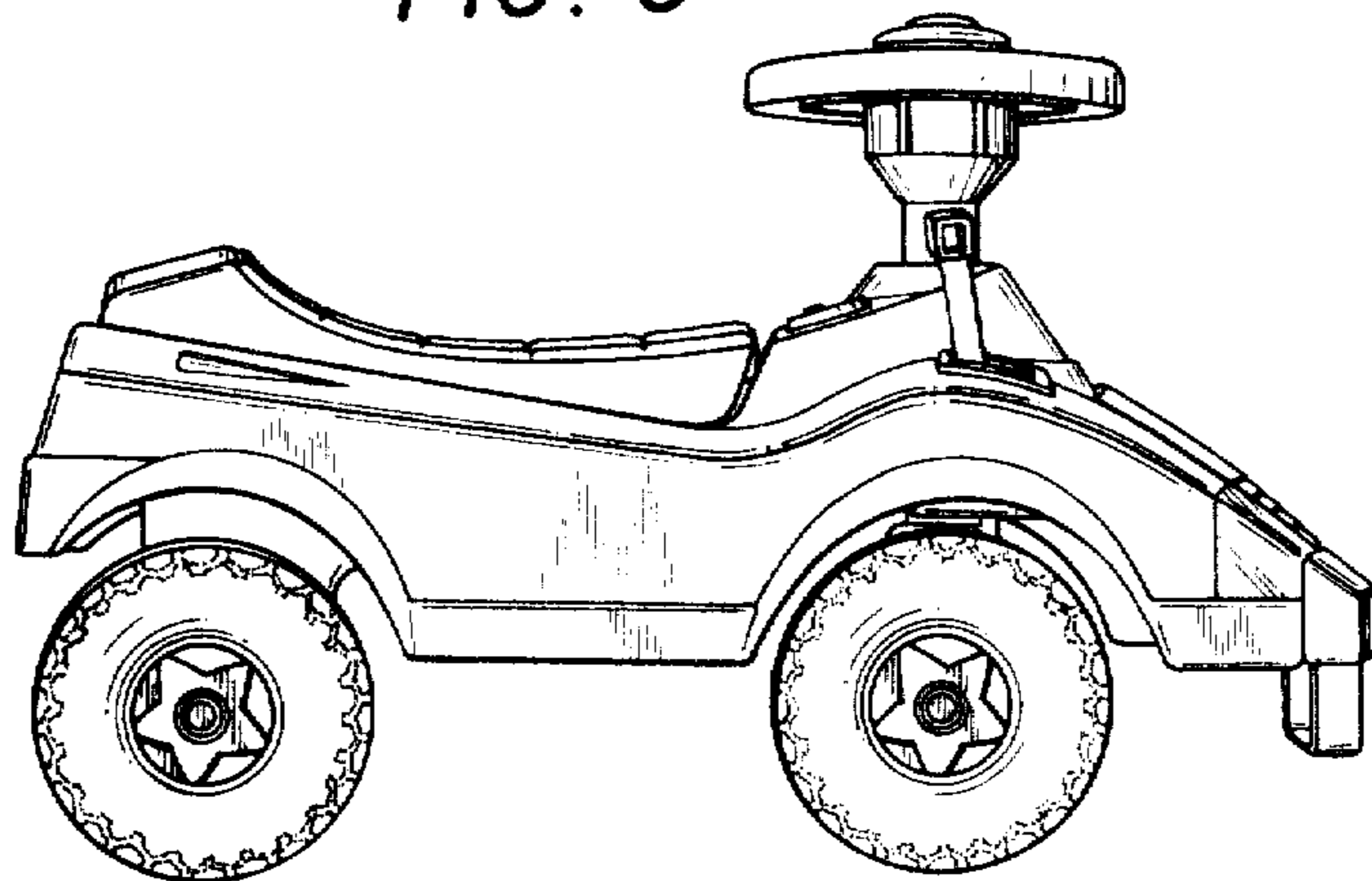

FIG. 4

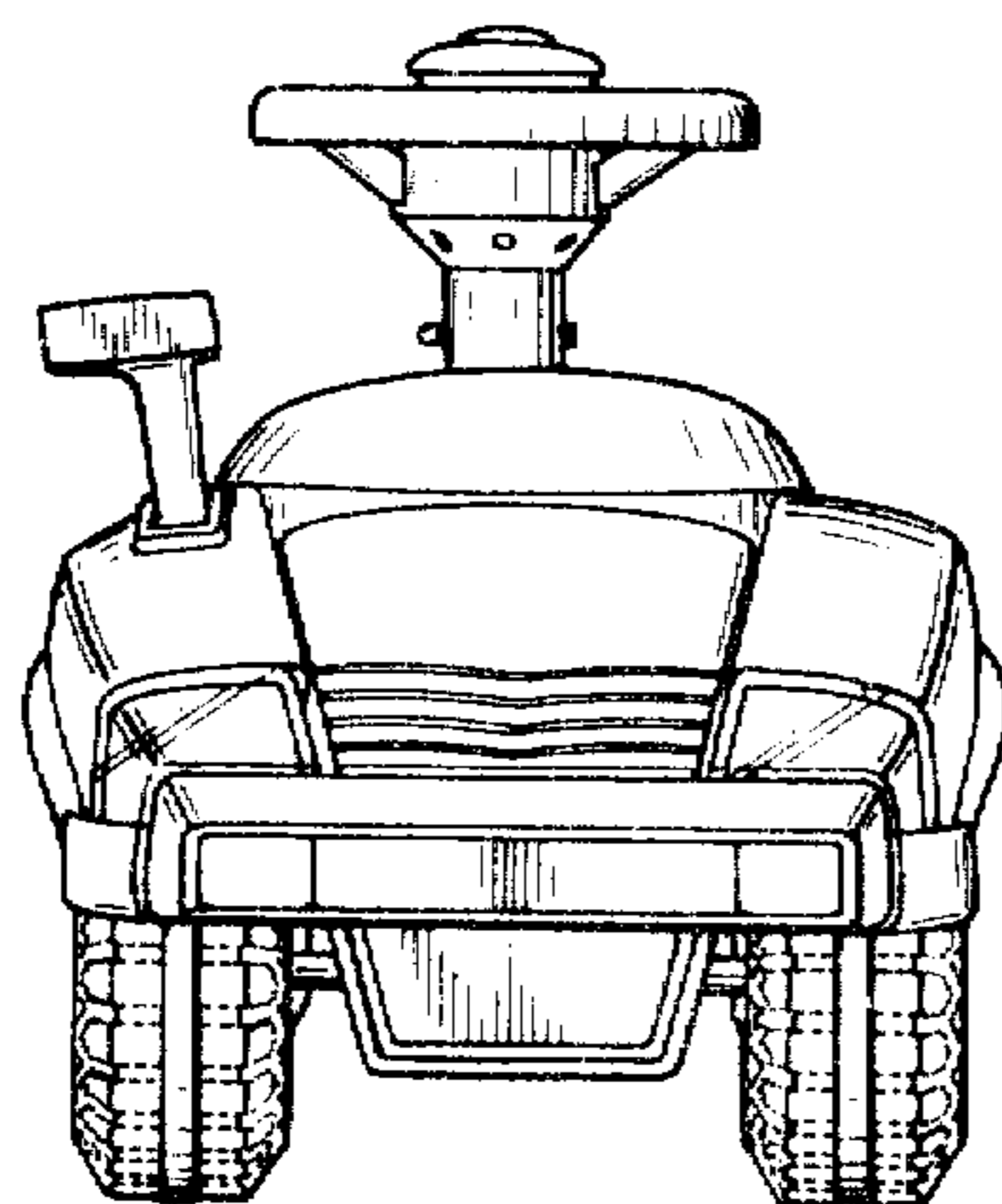

FIG. 5

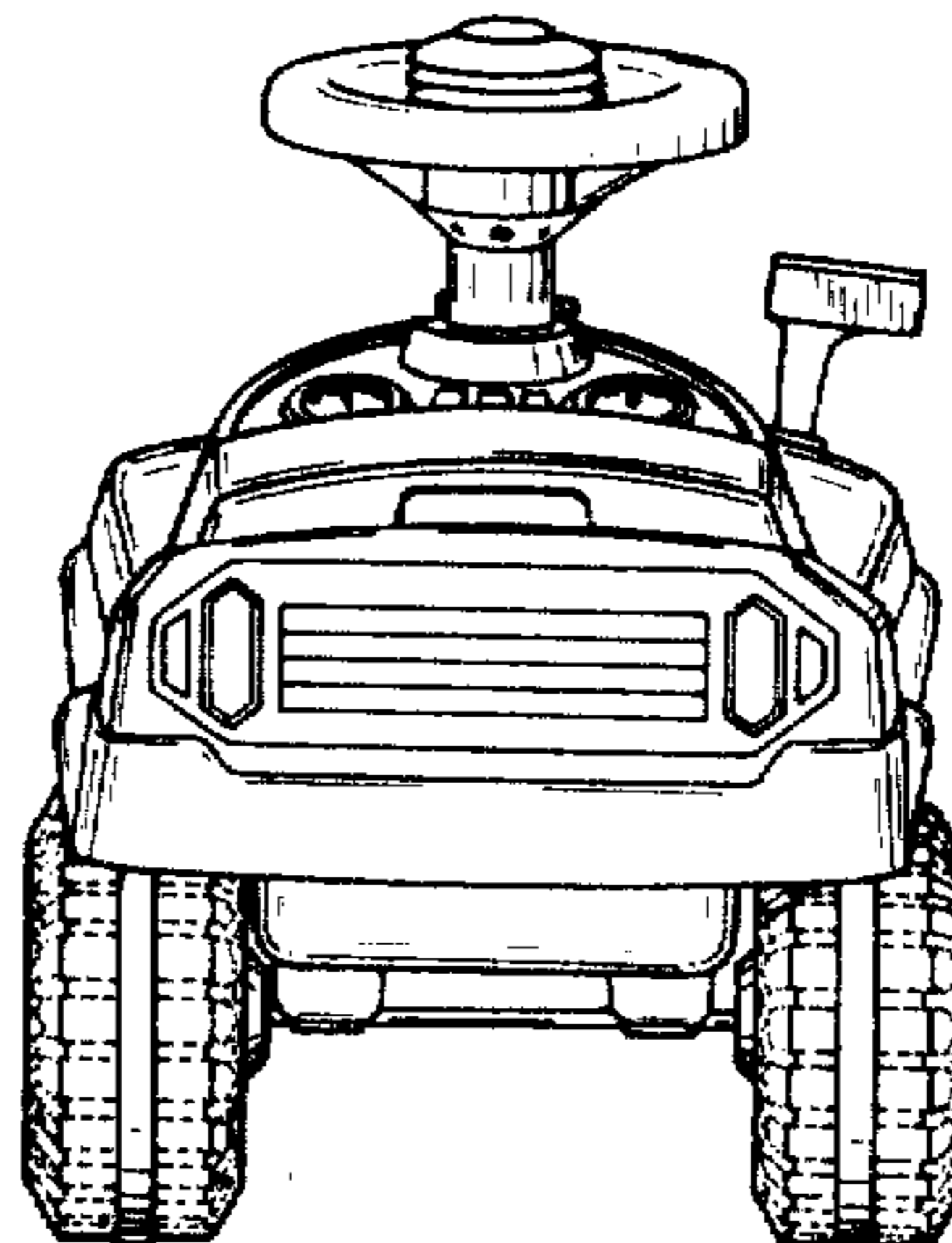

FIG. 6

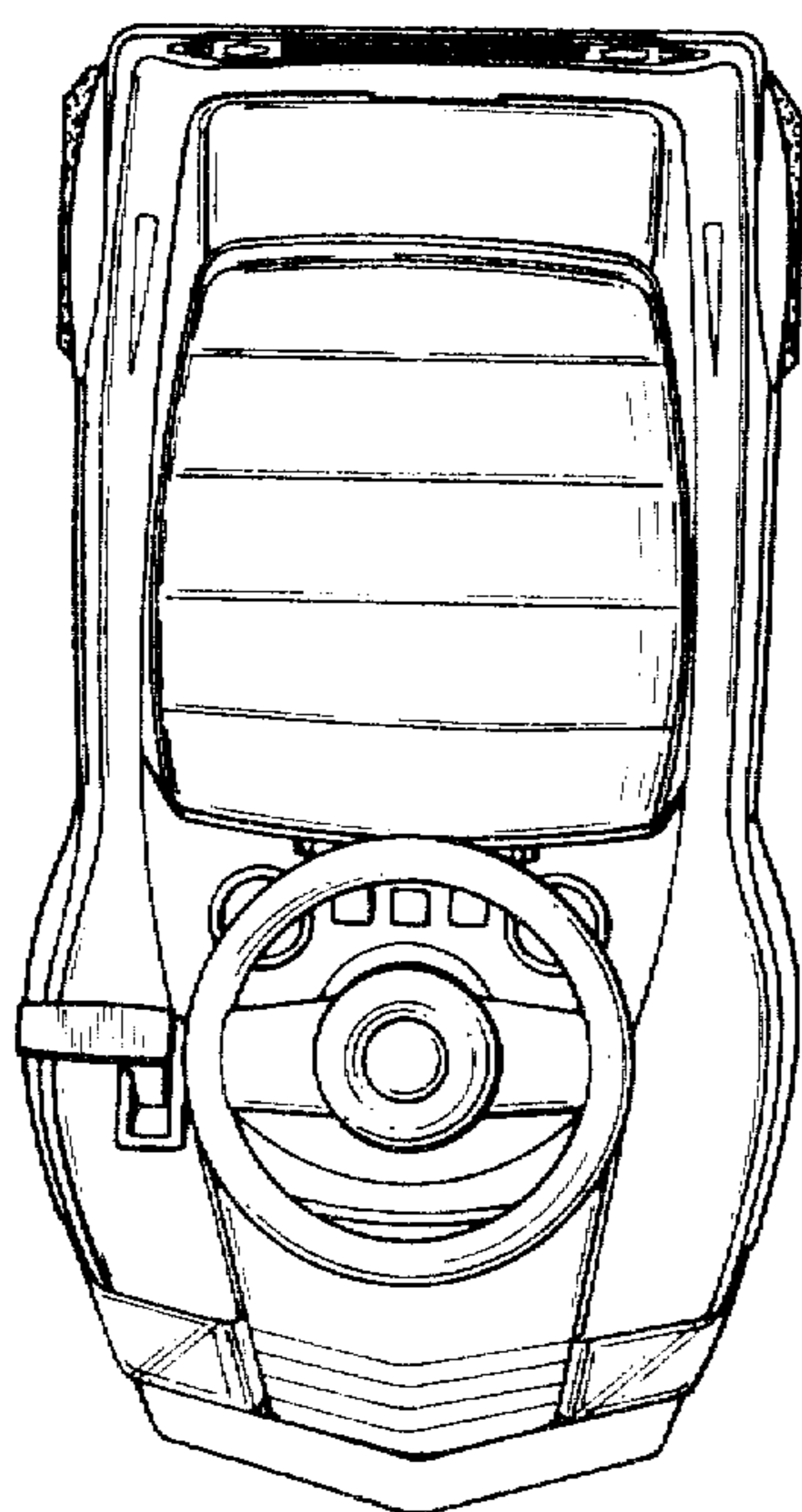

FIG. 7

