

[54] **VEHICLE FRAME**

[76] **Inventor:** Samuel P. Hundley, 1512 W.  
Springfield Ave., Champaign, Ill.  
61820

[\*\*] **Term:** 14 Years

[21] **Appl. No.:** 145,506

[22] **Filed:** Apr. 29, 1980

[51] **Int. Cl.** ..... D12-14

[52] **U.S. Cl.** ..... D21/71; D12/107

[58] **Field of Search** ..... D12/107; D21/71;  
280/87.01, 87.02 R, 282

[56] **References Cited**

**U.S. PATENT DOCUMENTS**

D. 127,915 6/1941 Weller, Jr. .... D12/107  
D. 195,473 6/1963 Hundley ..... D21/71

*Primary Examiner*—James M. Gandy  
*Attorney, Agent, or Firm*—Harvey B. Jacobson

[57] **CLAIM**

The ornamental design for a vehicle frame, as shown and described.

**DESCRIPTION**

FIG. 1 is a side elevational view of a vehicle frame showing my new design;

FIG. 2 is a top plan view thereof;

FIG. 3 is a front elevational view thereof; and

FIG. 4 is a rear elevational view thereof.

The broken lines showing the wheels, handlebars and seat are for illustrative purposes only.

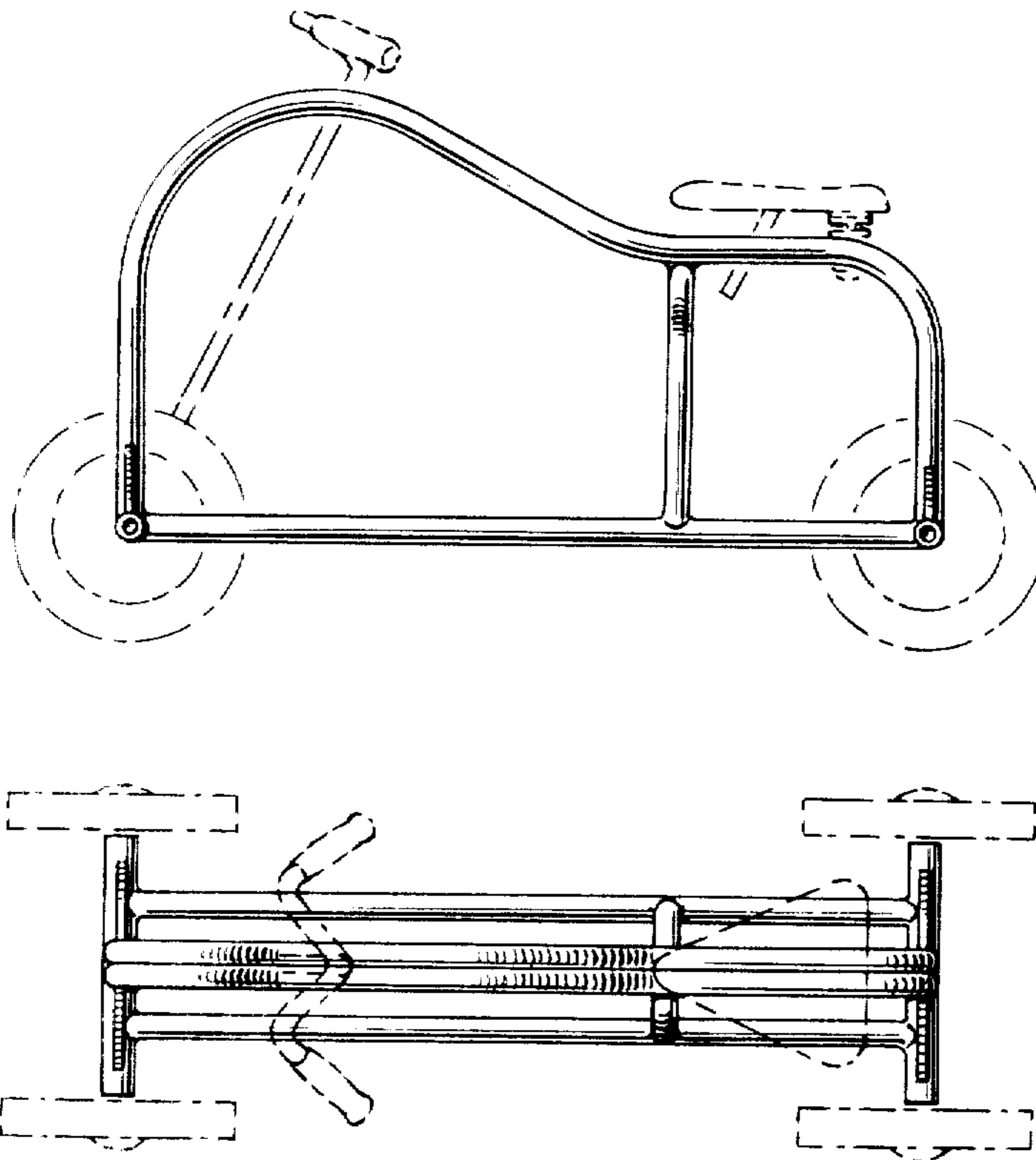

Fig. 1

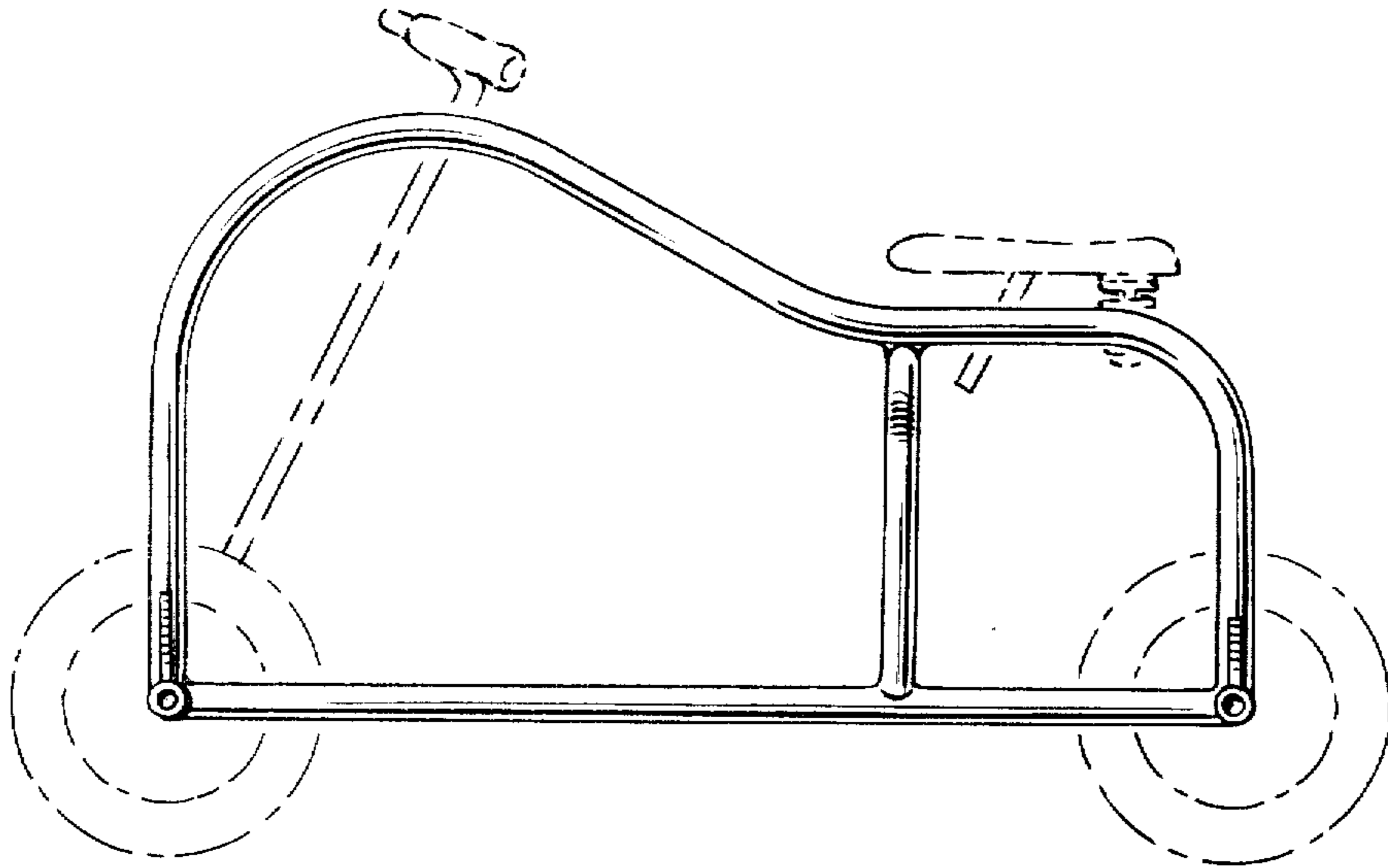

Fig. 2

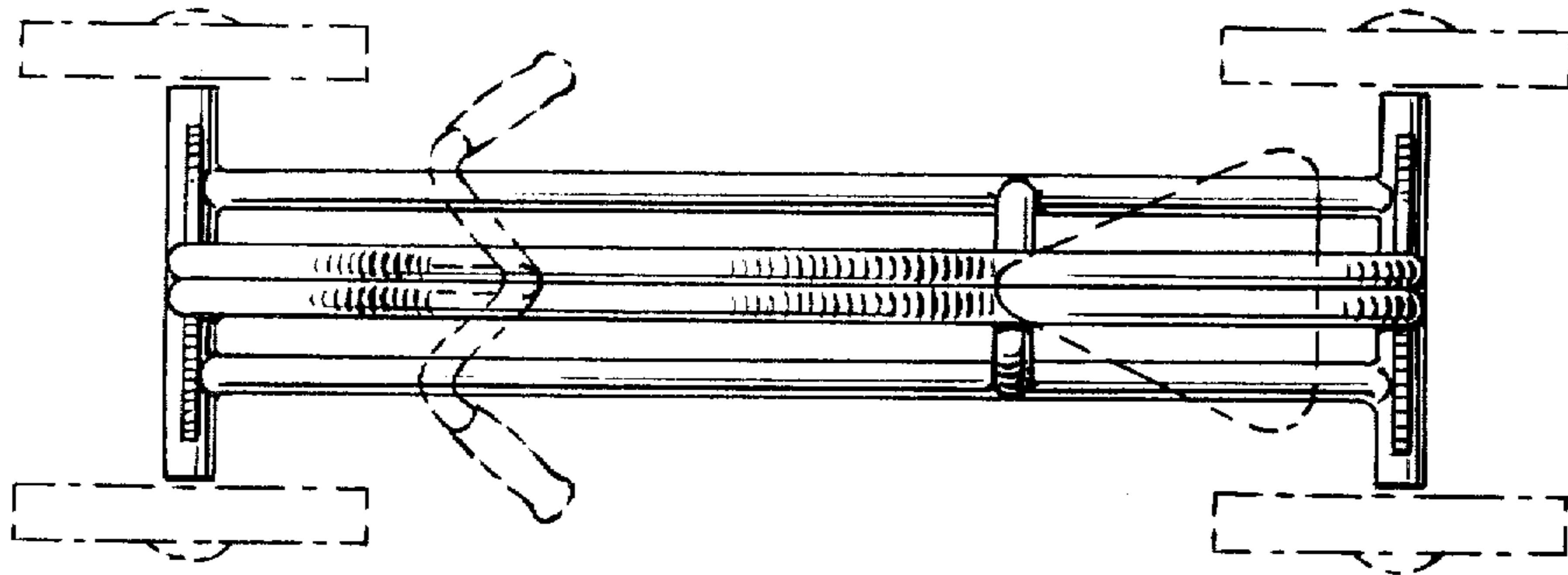

Fig. 3

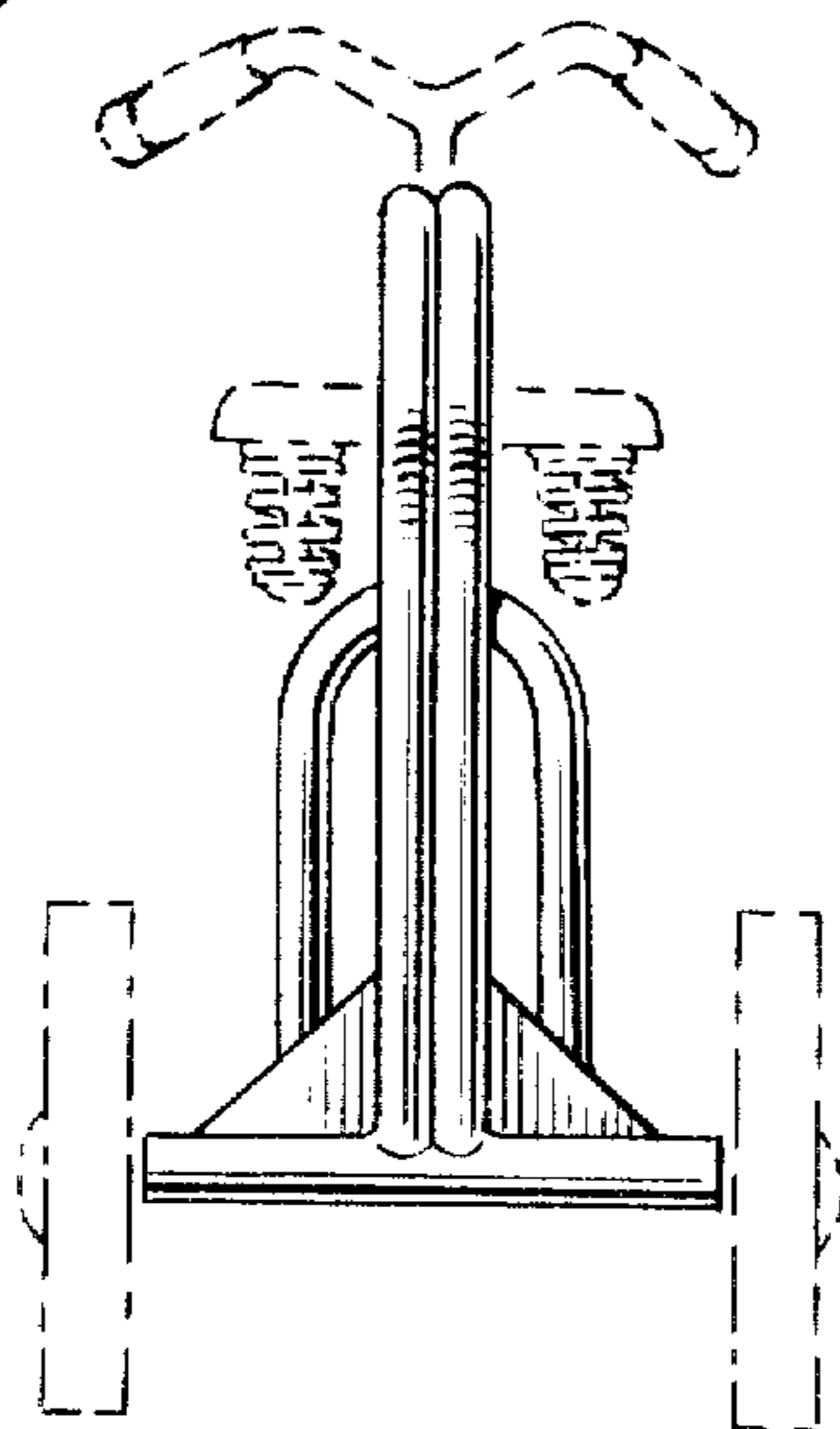

Fig. 4

