

[54] **VEHICLE LUGGAGE CARRIER**
[76] Inventor: **John A. Bott, 931 Lakeshore Dr., Grosse Pointe Shores, Mich. 48236**

D. 250,461 12/1978 Bott D12/157
D. 250,464 12/1978 Bott D12/157
4,106,680 8/1978 Bott 224/29 R
4,175,682 11/1979 Bott 224/309

[**] Term: **14 Years**
[21] Appl. No.: **39,197**
[22] Filed: **May 15, 1979**

Primary Examiner—James M. Gandy
Attorney, Agent, or Firm—Harness, Dickey & Pierce

[51] Int. Cl. **D12-16**
[52] U.S. Cl. **D12/157**
[58] Field of Search D12/157; 224/309, 321, 224/324, 325, 327

[57] **CLAIM**
The ornamental design for a vehicle luggage carrier, as shown and described.

[56] **References Cited**
U.S. PATENT DOCUMENTS
Re. 26,539 3/1969 Bott 224/321

DESCRIPTION

FIG. 1 is a top perspective view of a vehicle luggage carrier showing my new design, it being understood that the broken lines are for illustrative purposes only; FIG. 2 is a top plan view thereof; FIG. 3 is a side elevational view thereof; and FIG. 4 is an end elevational view thereof.

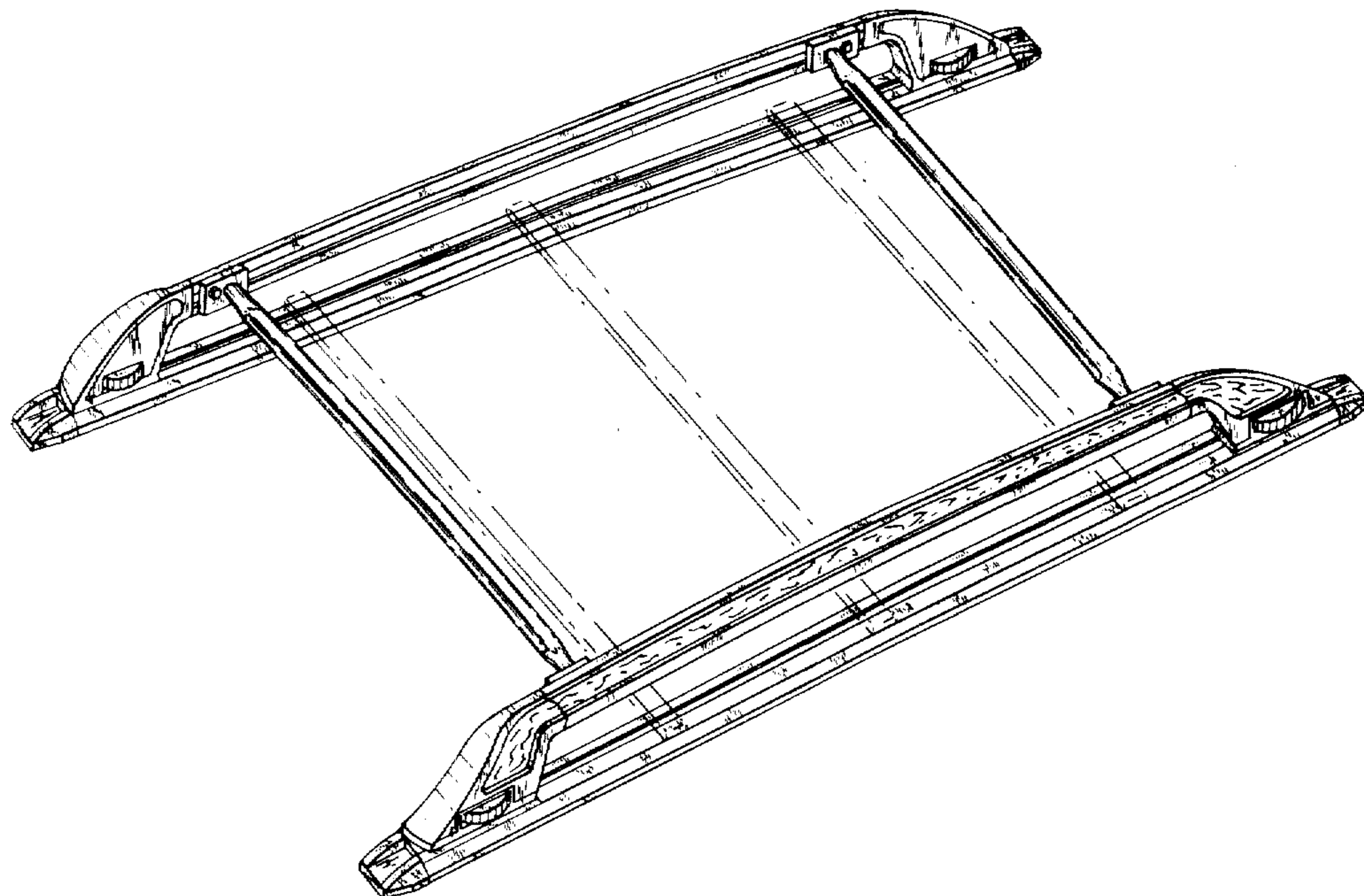

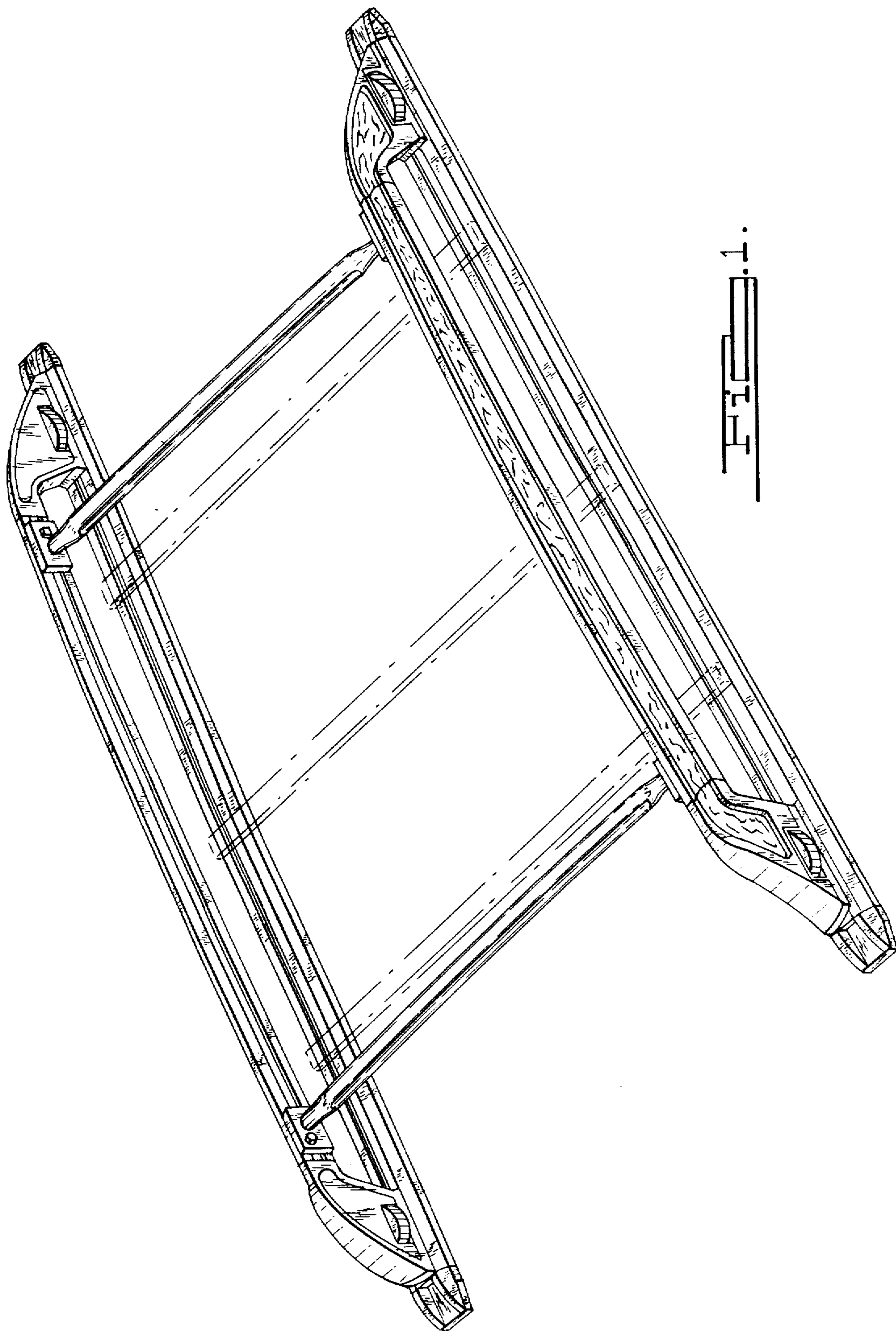

FIG. 1

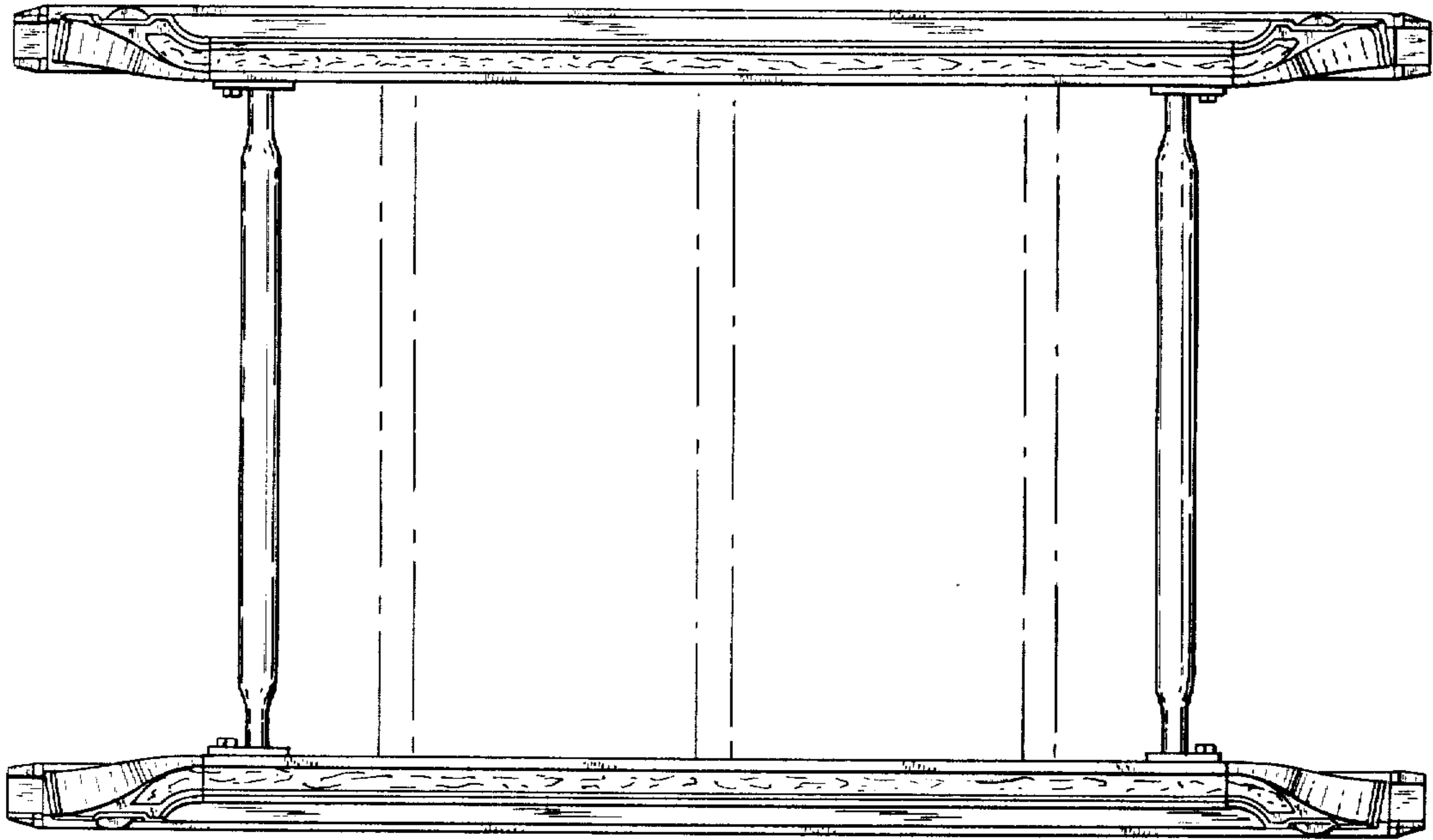

FIG. 2.

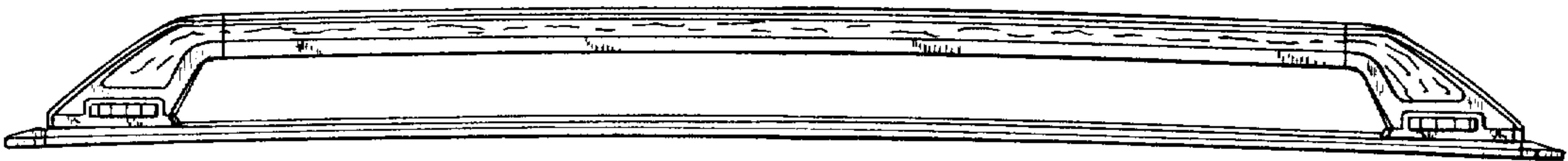

FIG. 3.

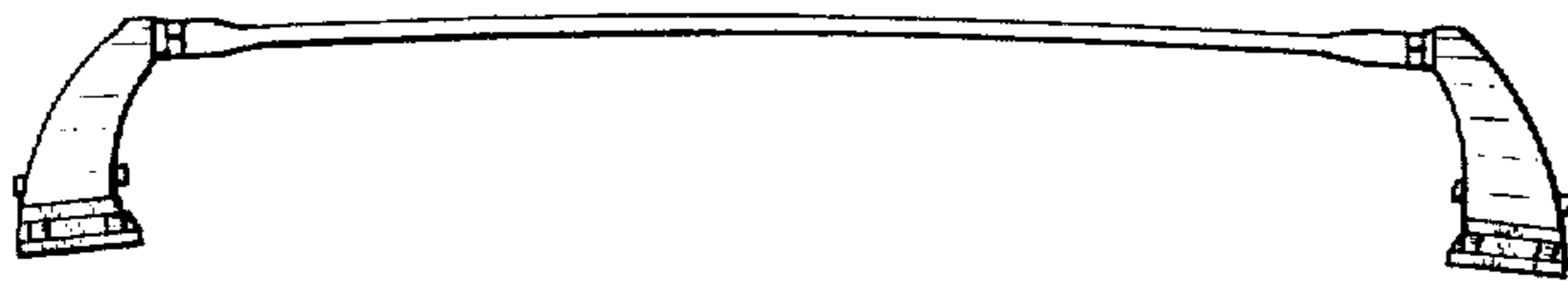

FIG. 4.