

[54] BICYCLE REAR DERAILLEUR

[75] Inventor: Nobuo Ozaki, Osaka, Japan

[73] Assignee: Maeda Industries, Ltd., Osaka, Japan

[**] Term: 14 Years

[21] Appl. No.: 30,740

[22] Filed: Apr. 17, 1979

[51] Int. Cl. D12-11

[52] U.S. Cl. D12/124

[58] Field of Search D12/124; 474/80-82

[56] References Cited

PUBLICATIONS

American Bicyclist & Motorcyclist, 12/77, p. 3, rear derailleur, top right side of page.

Primary Examiner—James M. Gandy

Attorney, Agent, or Firm—Birch, Stewart, Kolasch & Birch

[57] CLAIM

The ornamental design for a bicycle rear derailleur, as shown and described.

DESCRIPTION

FIG. 1 is a front elevational view of a bicycle rear derailleur with the tensioner in substantially intermediate vertical position;

FIG. 2 is a top plan view thereof;

FIG. 3 is a left side elevational view thereof;

FIG. 4 is a right side elevational view thereof;

FIG. 5 is a bottom plan view thereof;

FIG. 6 is a rear elevational view thereof;

FIG. 7 is a front elevational view thereof with the tensioner swung leftward; and

FIG. 8 is a front elevational view thereof with the tensioner swung rightward.

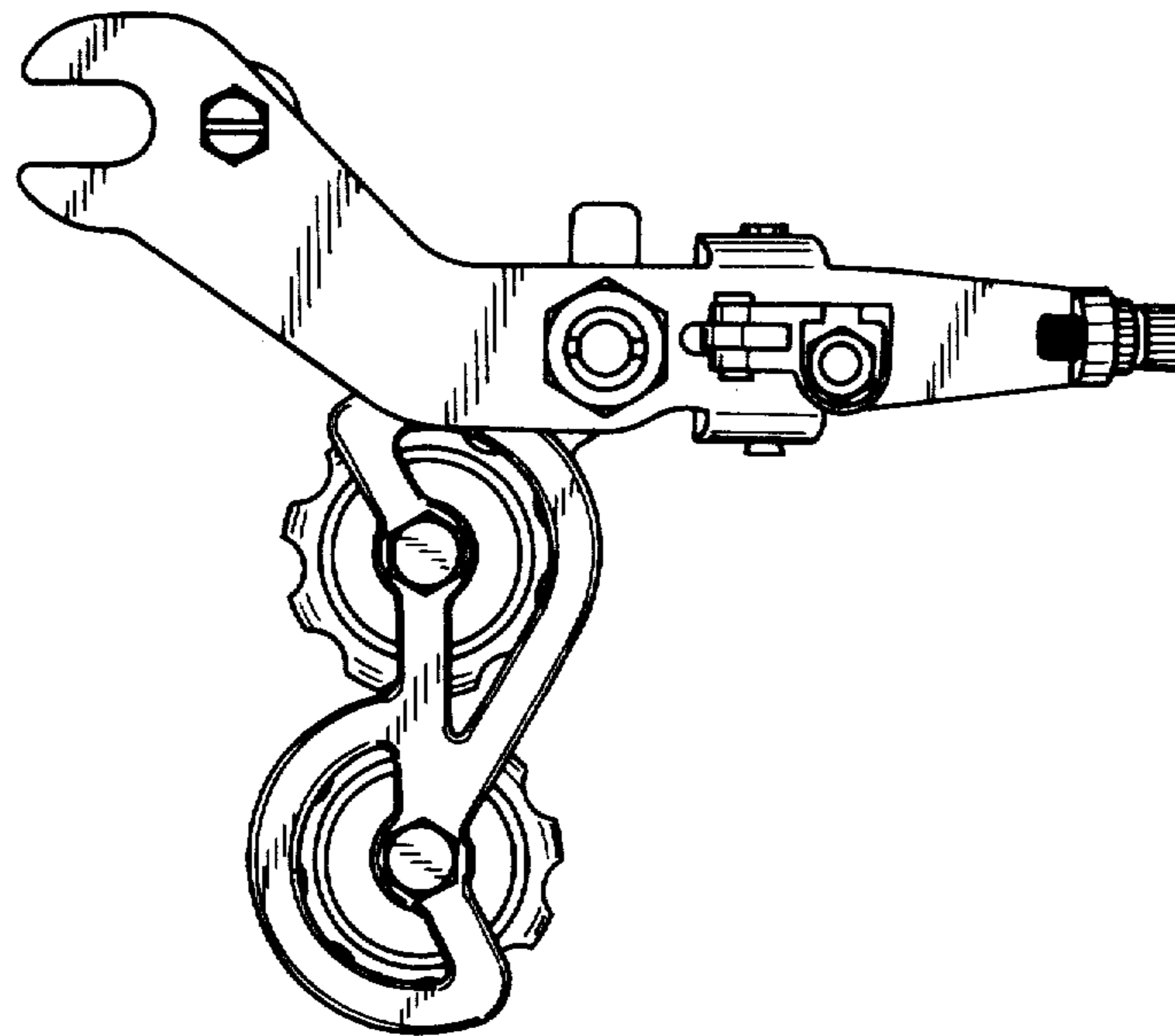

FIG.2

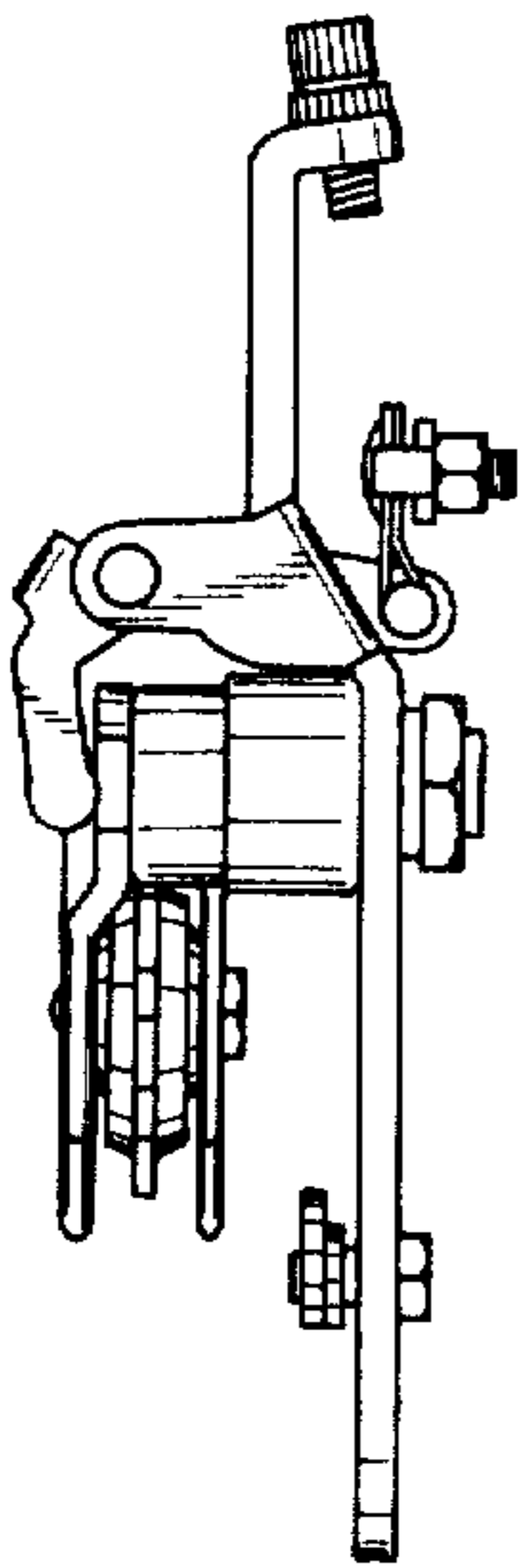

FIG.3

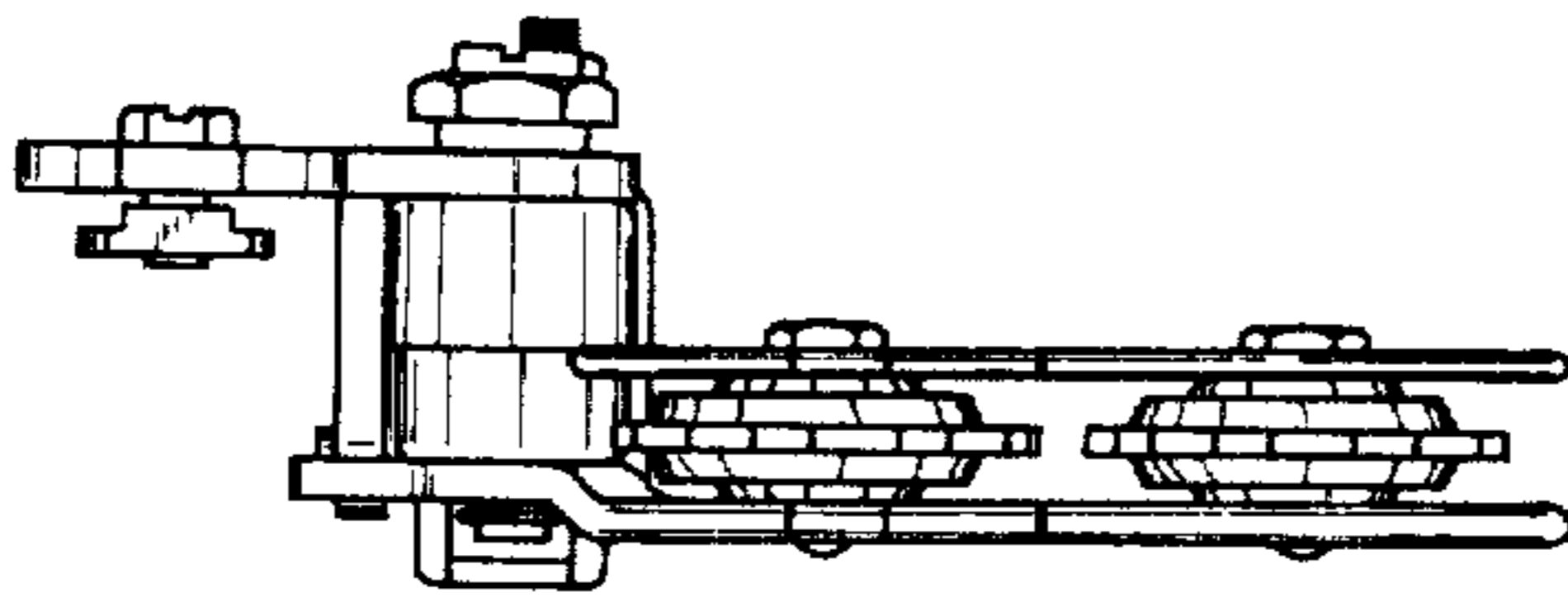

FIG.4

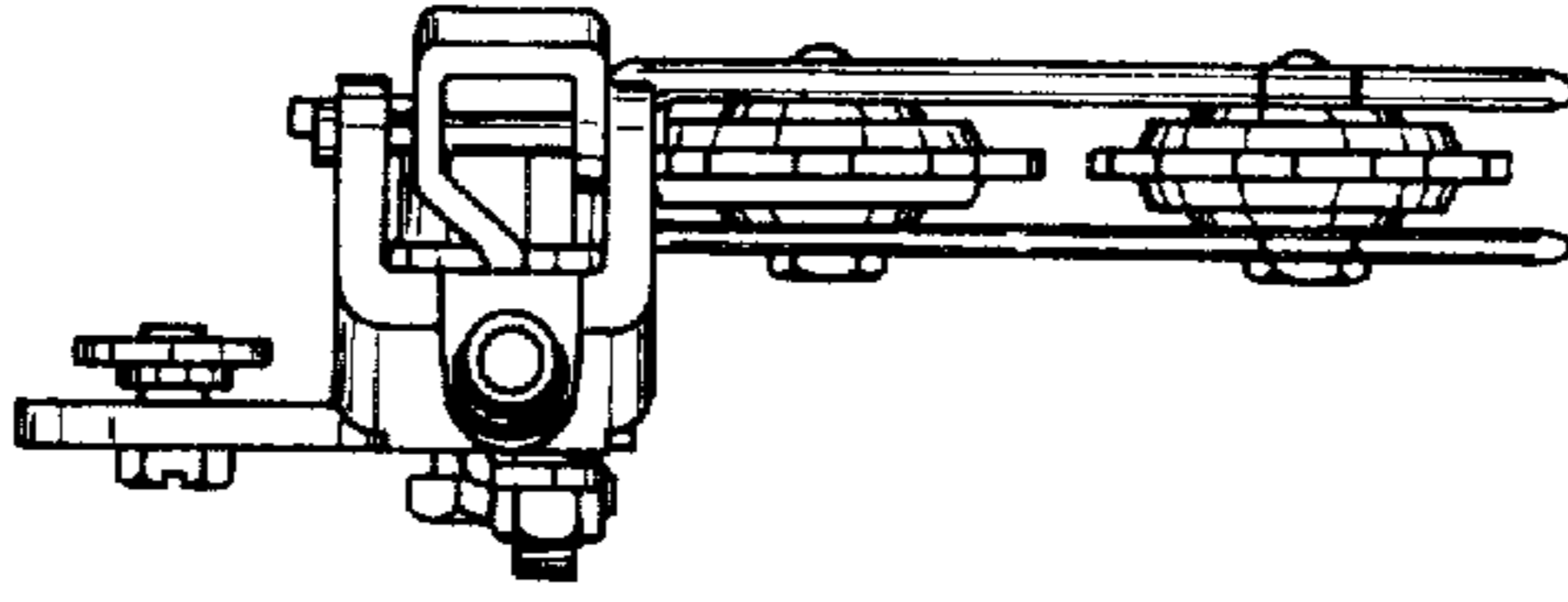

FIG.1

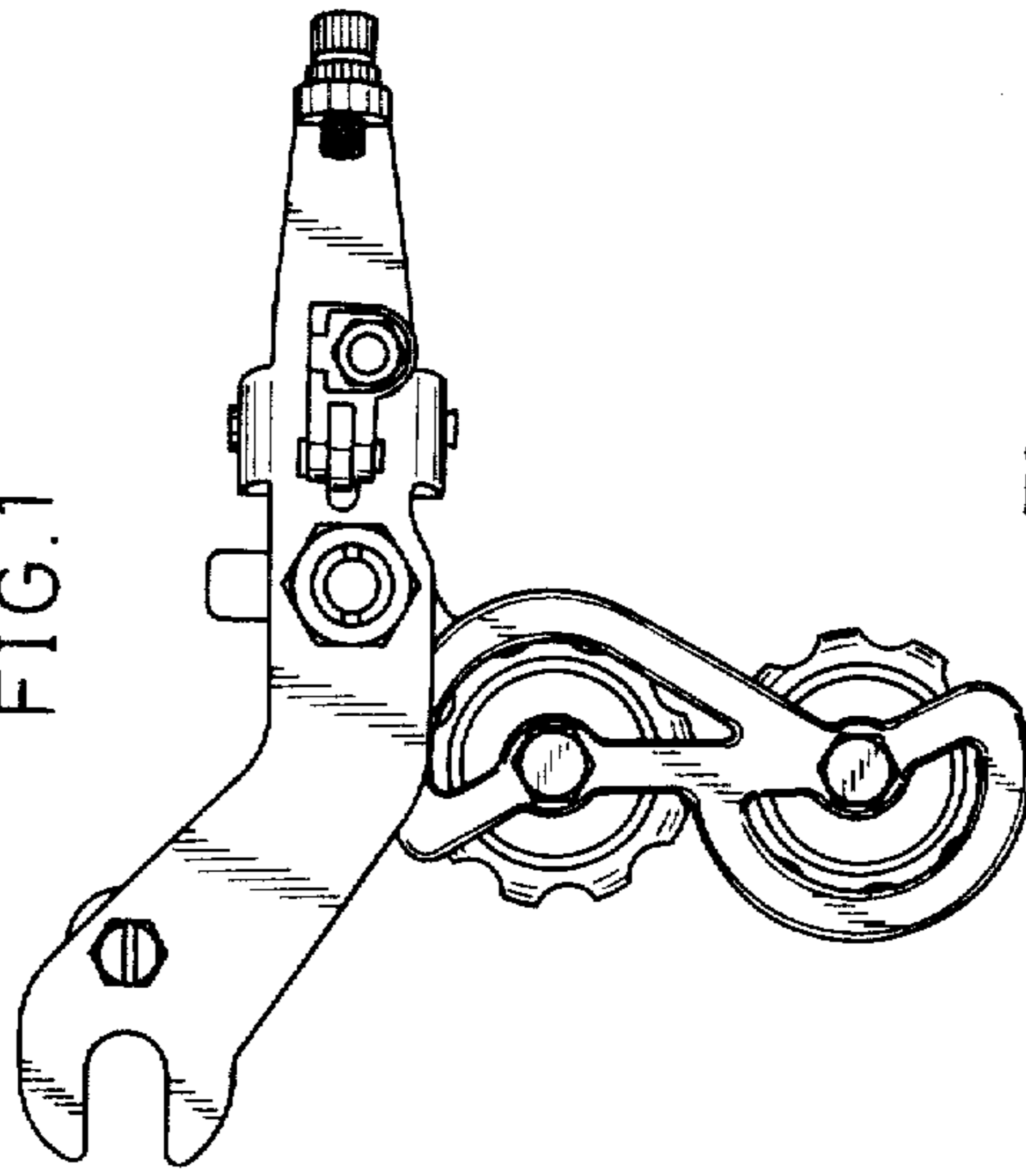

FIG.5

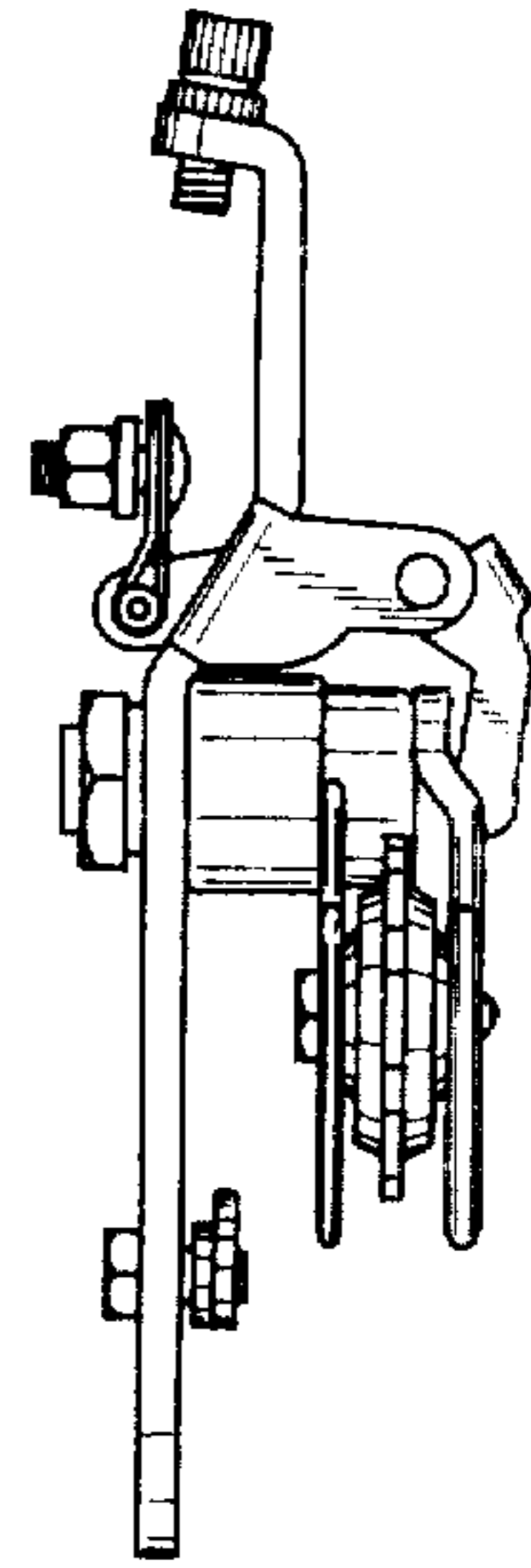

FIG.6

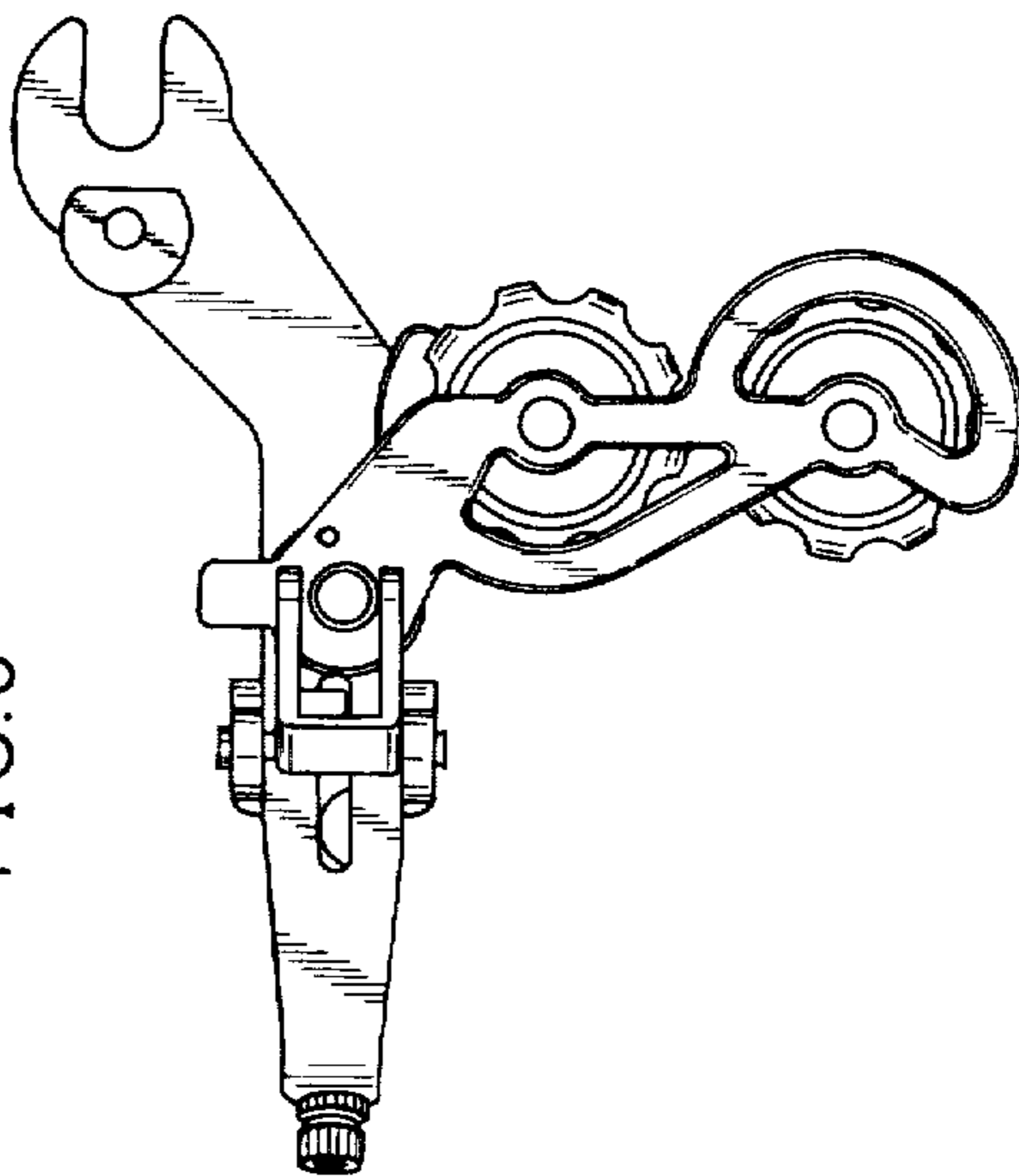

FIG.8

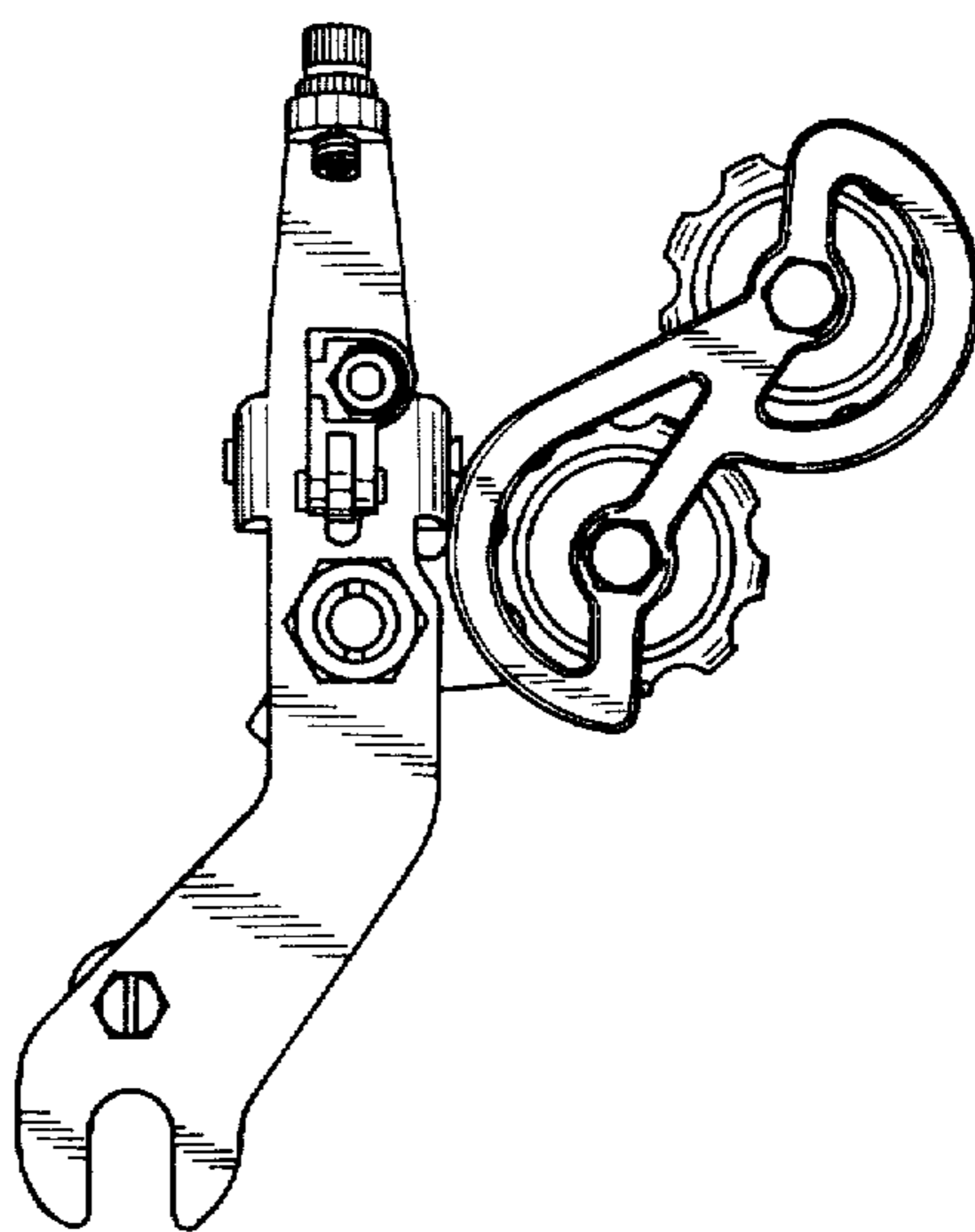

FIG.7

