

[54] **VEHICLE REAR VIEW MIRROR**
 [75] Inventor: **Fritz Niggemann**, Essen, Fed. Rep. of Germany
 [73] Assignee: **Busch & Müller**, Meinerzhagen, Fed. Rep. of Germany
 [**] Term: **14 Years**
 [21] Appl. No.: **3,936**
 [22] Filed: **Jan. 16, 1979**

[30] **Foreign Application Priority Data**
 Jul. 18, 1978 [DE] Fed. Rep. of Germany 523
 Sep. 18, 1978 [DE] Fed. Rep. of Germany 525
 [51] **Int. Cl.** **D12-16**
 [52] **U.S. Cl.** **D12/189**
 [58] **Field of Search** **D12/189; D6/243, 245; 350/307, 293, 288; 248/476, 475 R**

[56] **References Cited**
U.S. PATENT DOCUMENTS
 3,316,052 4/1967 Ross 350/293
FOREIGN PATENT DOCUMENTS
 793327 4/1958 United Kingdom 350/307

OTHER PUBLICATIONS
 Honest Charley Catalog, 1975, p. M-9, Mirror 32-40-8-A & 32-921L, top right side of page.
Primary Examiner—James M. Gandy

Attorney, Agent, or Firm—Jacobs & Jacobs

[57] **CLAIM**
 The ornamental design for a vehicle rear view mirror, as shown and described.

DESCRIPTION

FIG. 1 is a front elevational view of a vehicle rear view mirror showing my new design;
 FIG. 2 is a sectional bottom plan view thereof along line 2—2 in FIG. 1 looking in the direction of the arrows;
 FIG. 3 is a side elevational view thereof;
 FIG. 4 is a sectional bottom plan view thereof along a plane similar to line 2—2 in FIG. 1 and showing the mirror in an alternate position;
 FIG. 5 is a sectional bottom plan view thereof along a plane similar to line 2—2 in FIG. 1 and showing the mirror in still another alternate position;
 FIG. 6 is a front elevational view of a vehicle rear view mirror showing a second embodiment of my new design;
 FIG. 7 is a sectional bottom plan view taken along line 7—7 in FIG. 6 looking in the direction of the arrows;
 FIG. 8 is a fragmentary side elevational view of the second embodiment with the mirror in an alternate position; and
 FIG. 9 is a fragmentary side elevational view of the second embodiment with the mirror in still another alternate position.
 The mirror support has been broken away in FIGS. 8 and 9 for convenience of illustration.
 The rear of the mirror is understood to be convex and unornamented.

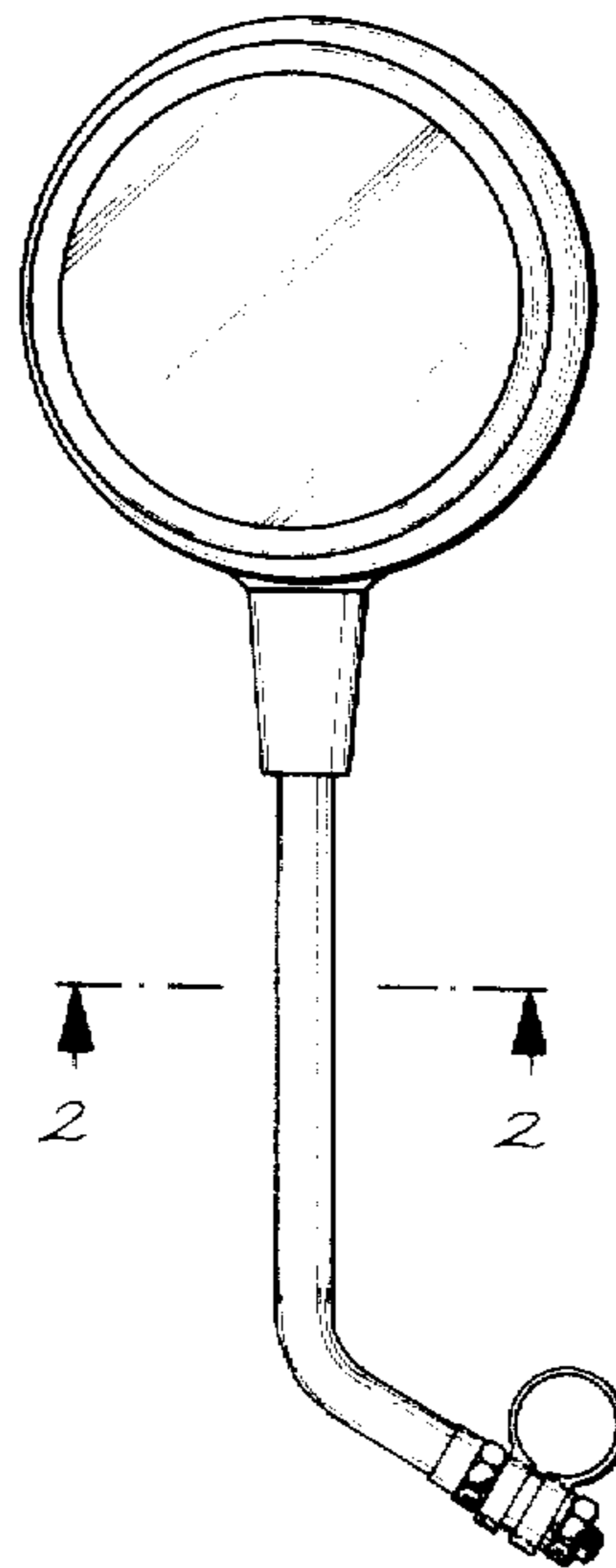

FIG 1

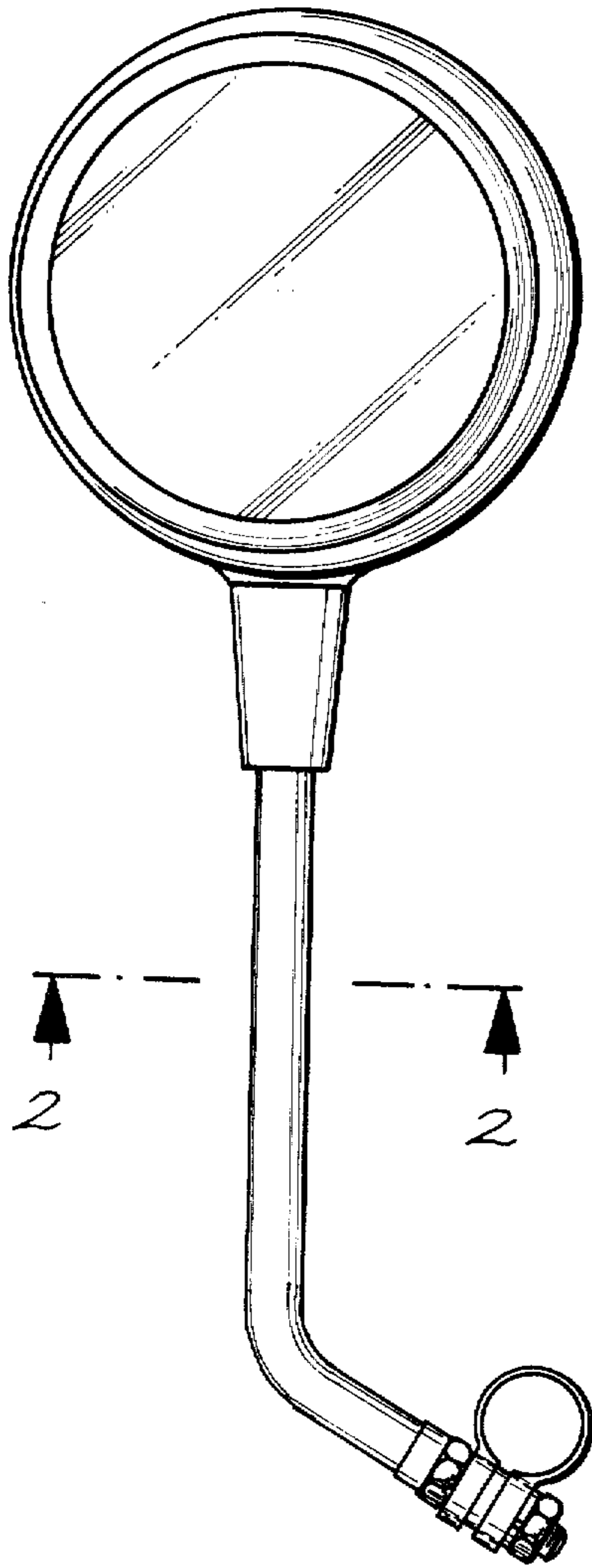

FIG 3

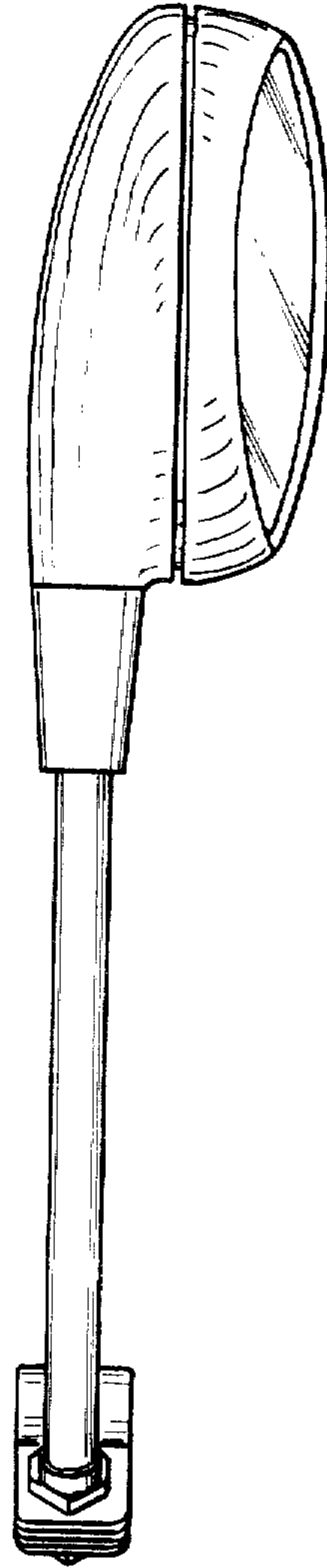

FIG 2

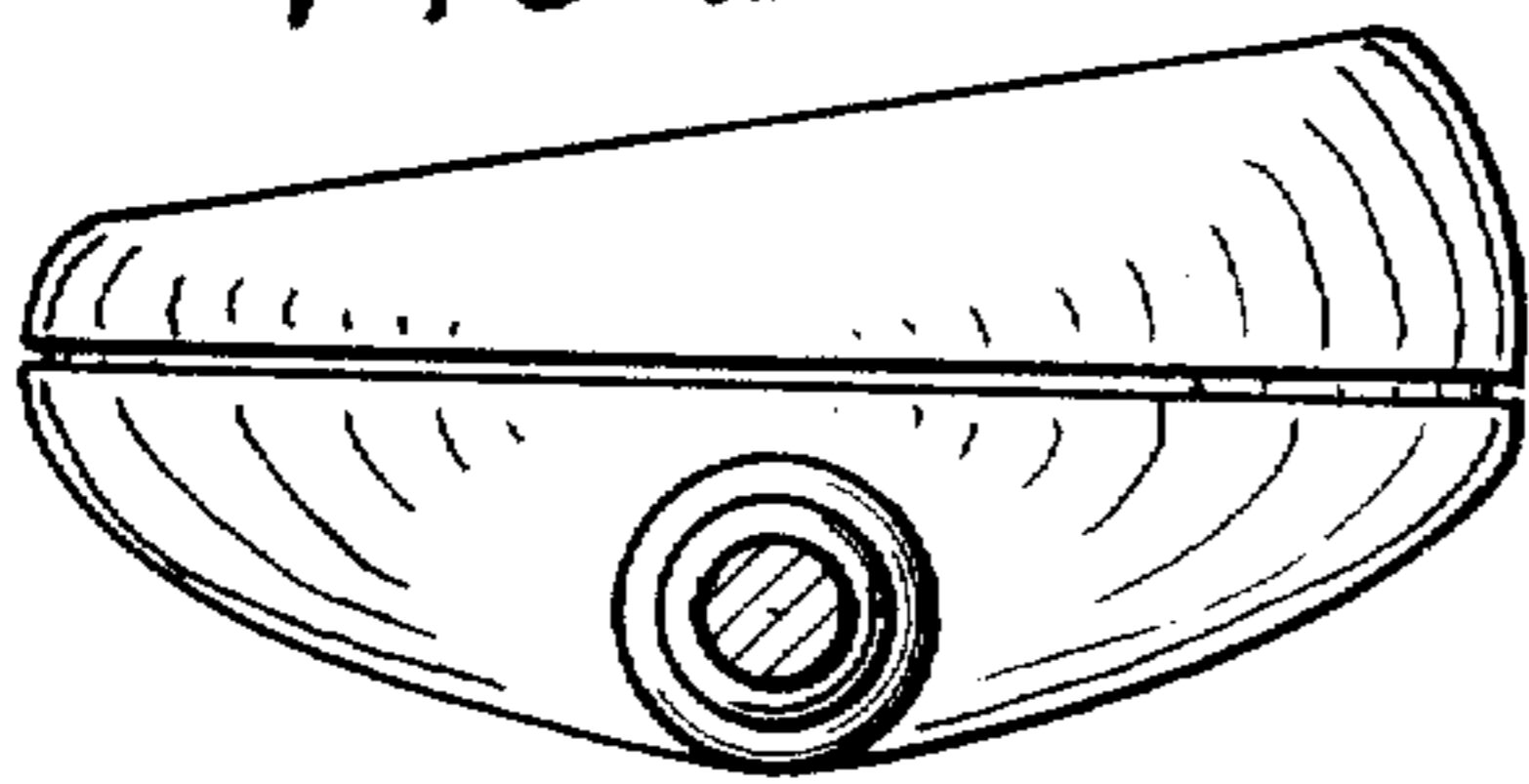

FIG 4

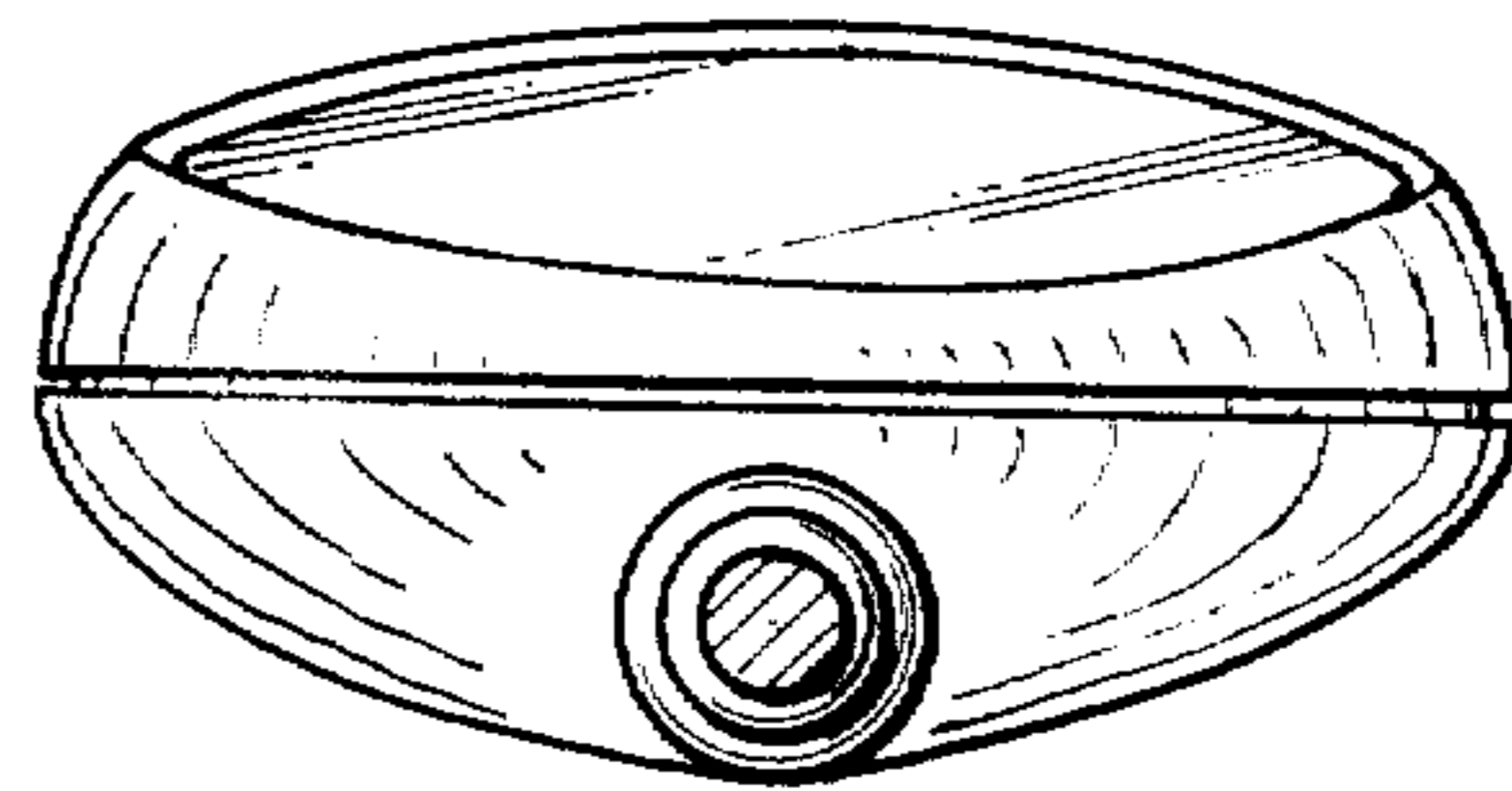

FIG 5

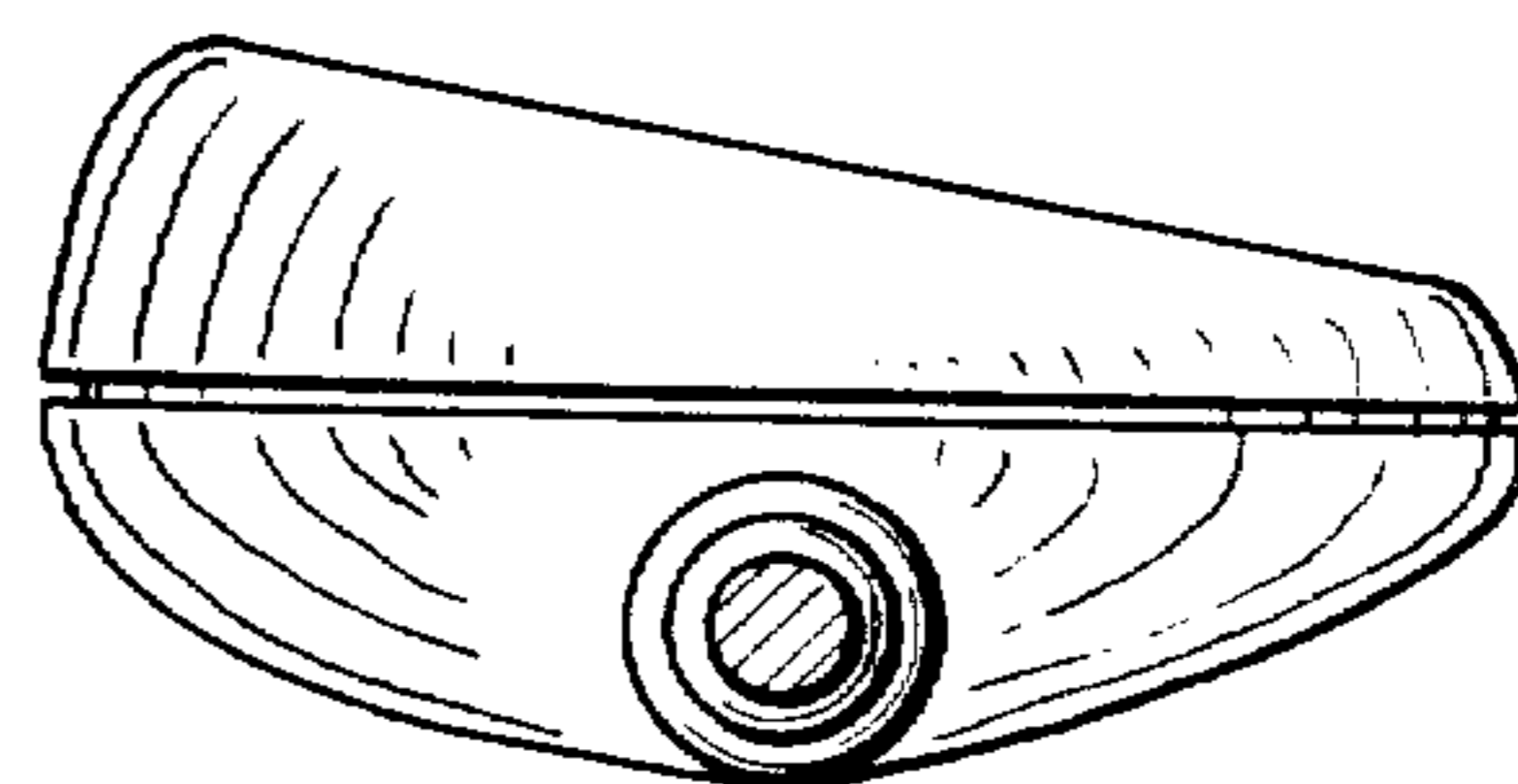

FIG 6

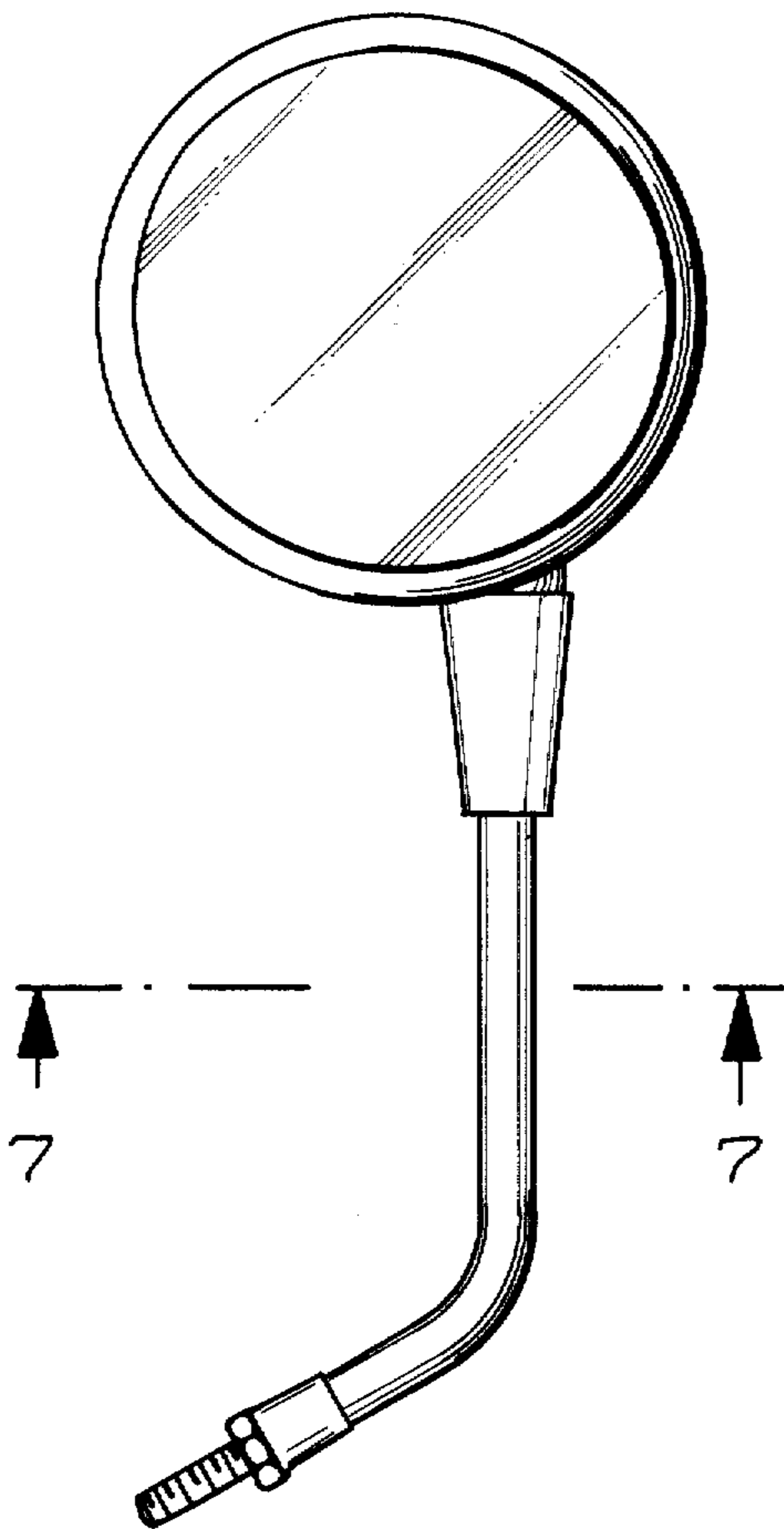

FIG 8



FIG 9

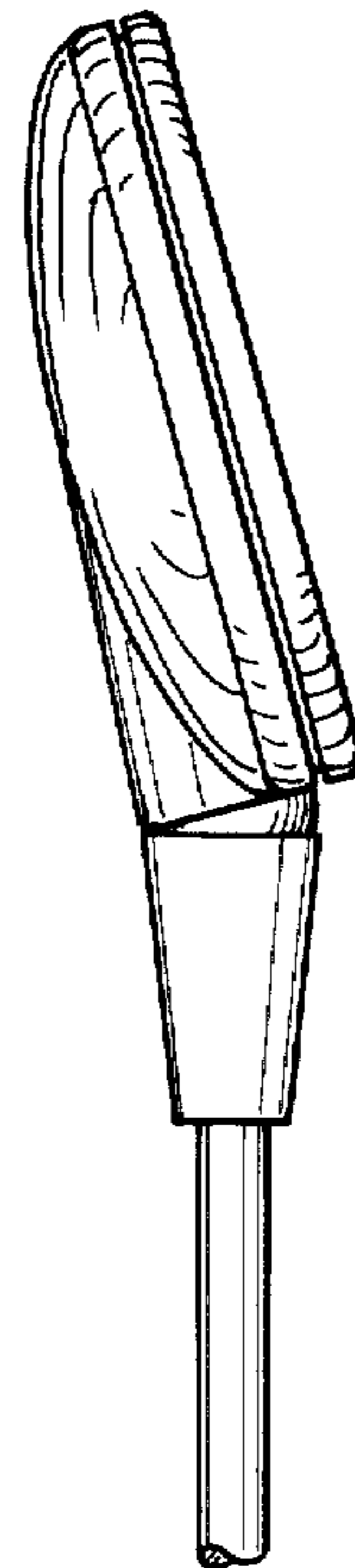

FIG 7

