

[54] THREE WHEEL MOTORCYCLE BODY

[75] Inventors: James S. Kaiser, Rte. #3 Crawford Dr., Proctorville, Ohio 45669; John D. Vincent, 585 McCutcheon, Columbus, Ohio 43230; Roger C. Vincent, 128 Cleveland Ave., Milford, Ohio 45150; Ricky L. Davie, Orient, Ohio

[73] Assignees: James Stewart Kaiser, Proctorville; John Denny Vincent, Columbus; Roger C. Vincent, Milford, all of Ohio

[**] Term: 14 Years

[21] Appl. No.: 92,201

[22] Filed: Nov. 7, 1979

[51] Int. Cl. D12-11

[52] U.S. Cl. D12/110; D12/112; 180/215; 280/202; 280/210; 280/281 B

[58] Field of Search D12/110, 112; 180/215; 280/202, 210, 281 B

[56] References Cited

U.S. PATENT DOCUMENTS

D. 165,690	1/1952	Kistler	D12/110
D. 172,215	5/1954	Brown	D12/110
D. 175,745	10/1955	Schreckengost	D12/112
D. 184,235	1/1959	Mann	D12/110

Primary Examiner—Veronica O’Keefe
Attorney, Agent, or Firm—Frost & Jacobs

[57] CLAIM

The ornamental design for a three wheel motorcycle body, substantially as shown and described.

DESCRIPTION

FIG. 1 is a perspective view of a three-wheel motorcycle body showing our new design; FIG. 2 is a side elevational view; FIG. 3 is a front elevational view; FIG. 4 is a rear elevational view; FIG. 5 is a top plan view; and FIG. 6 is a bottom view.

The side elevational view not shown is substantially identical to the side elevational view shown.

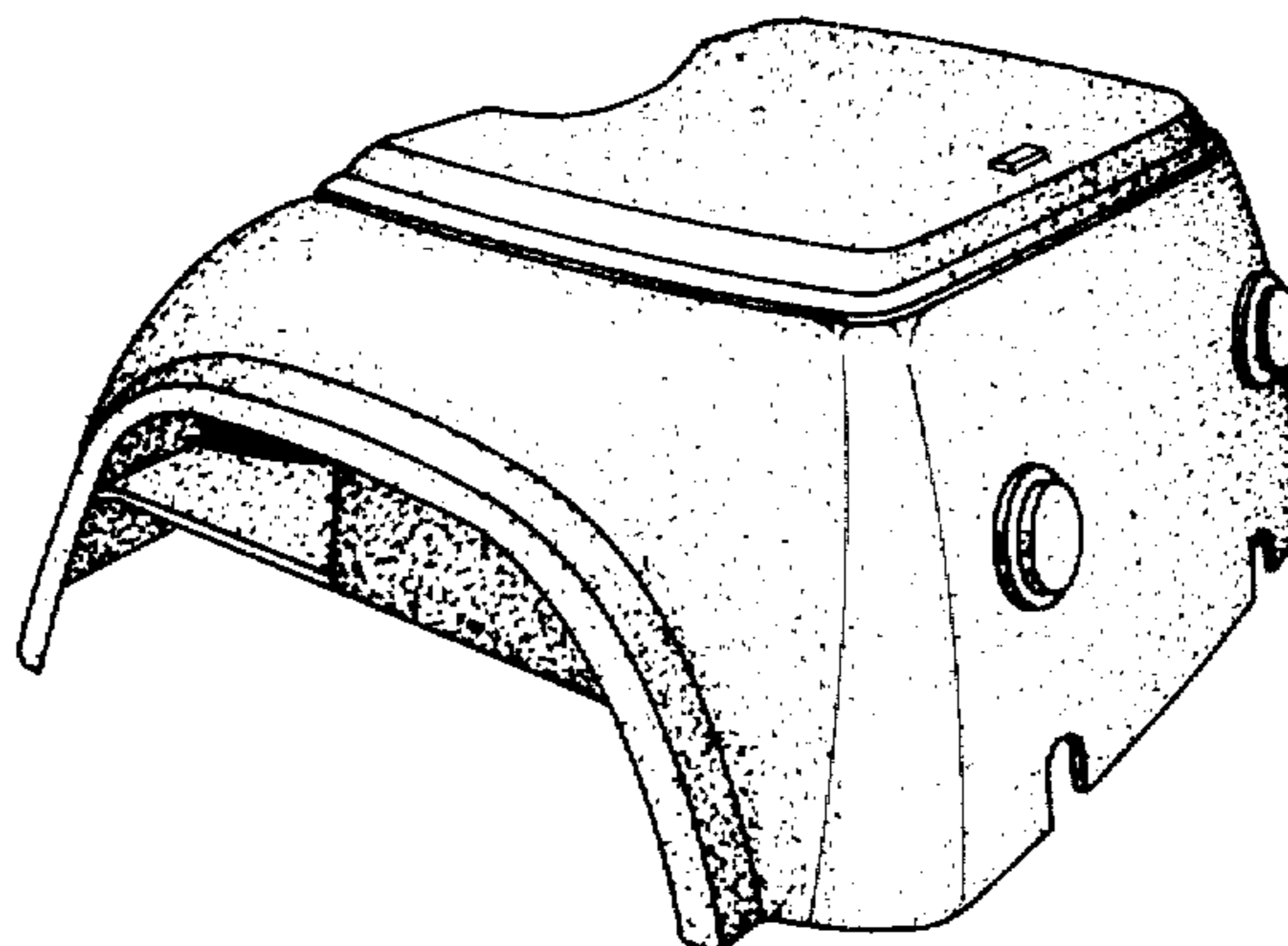

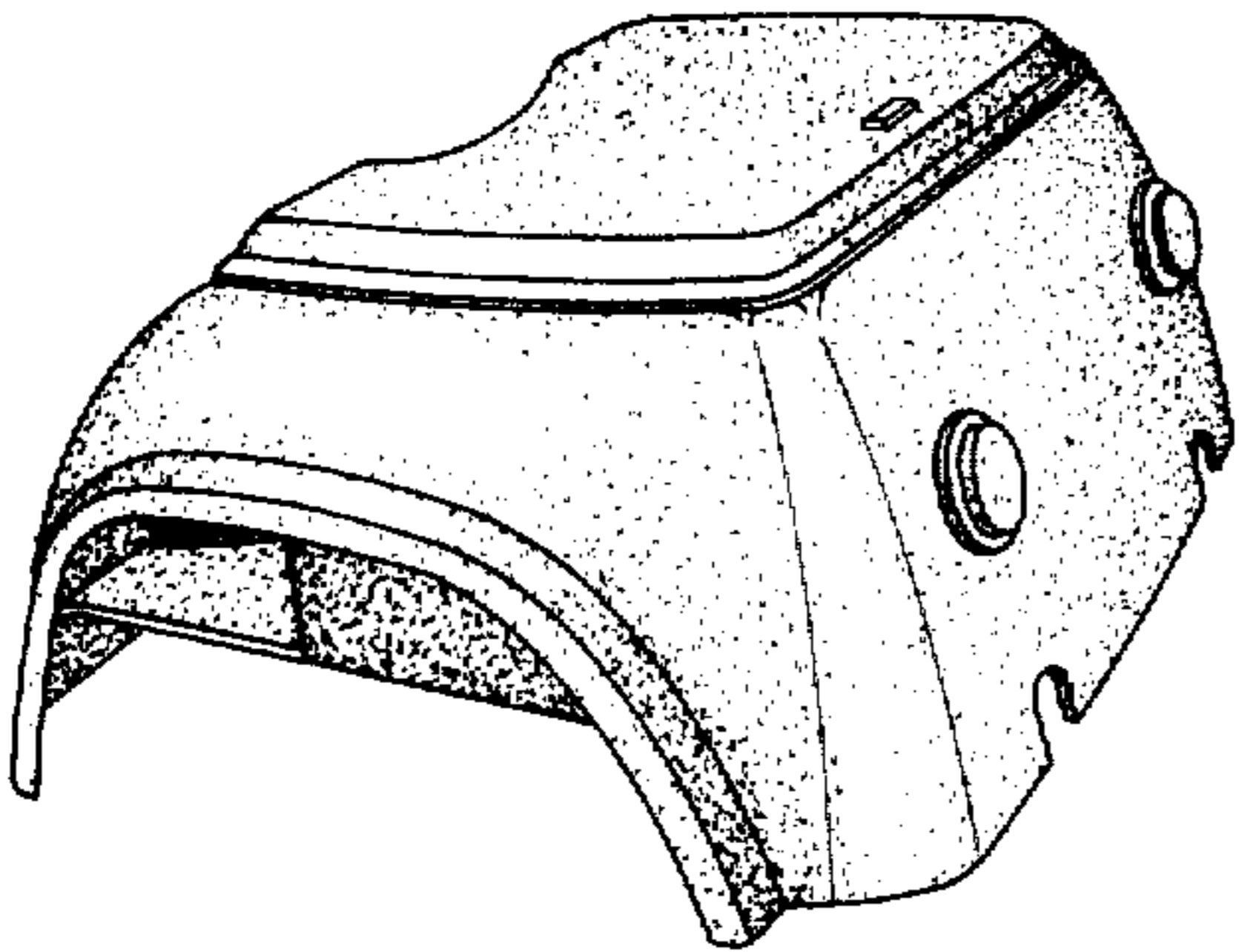

FIG 1

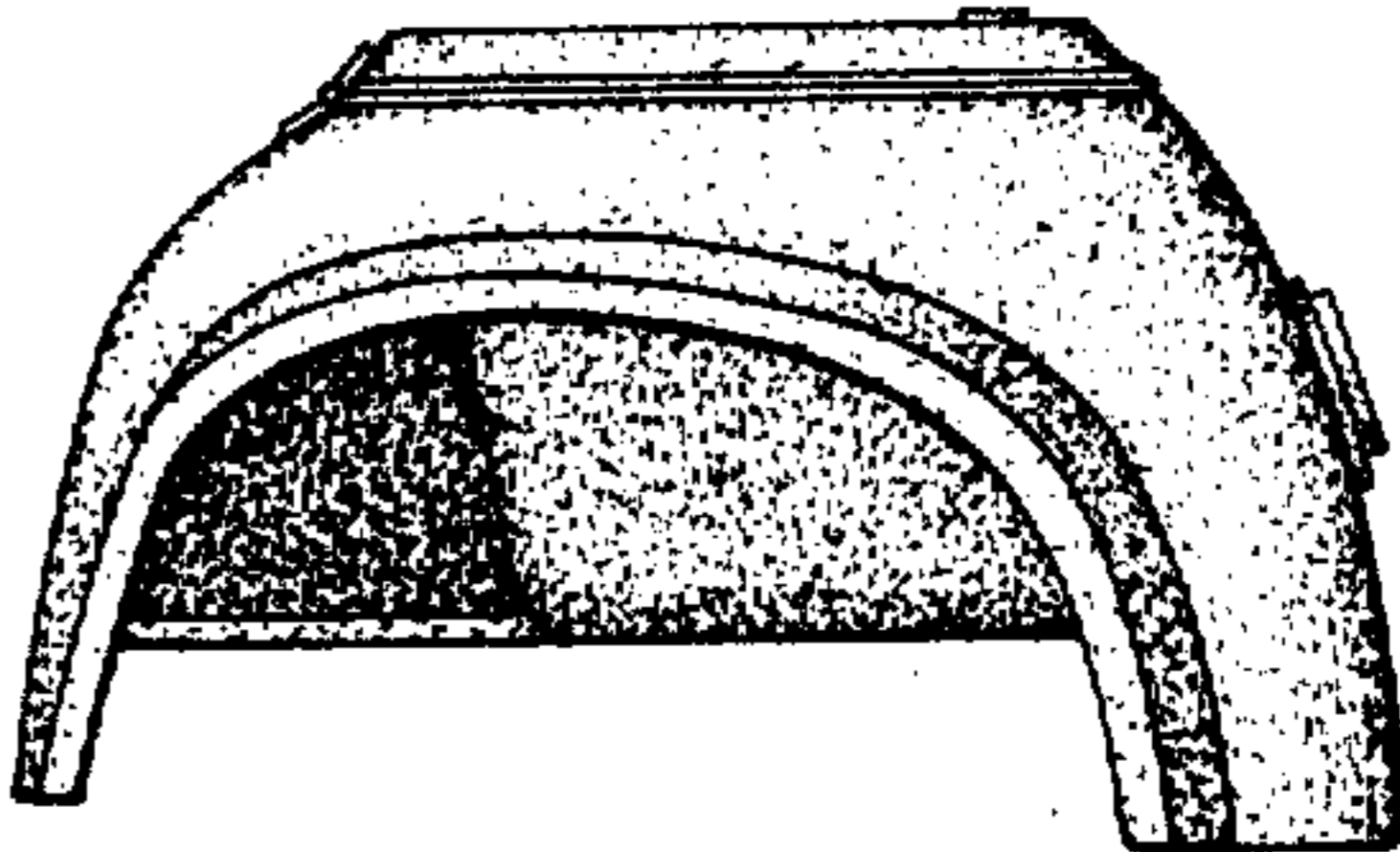

FIG 2

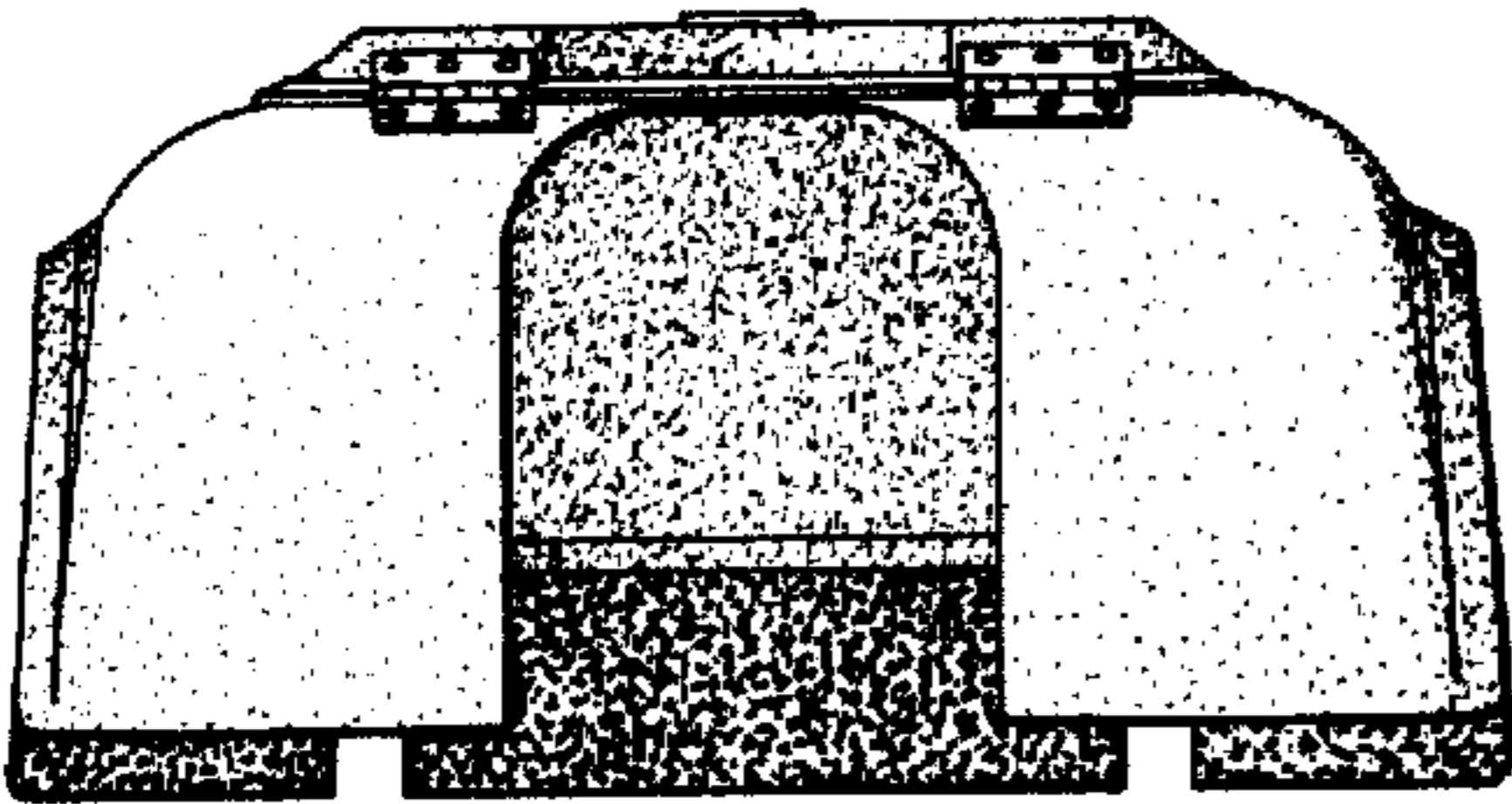

FIG 3

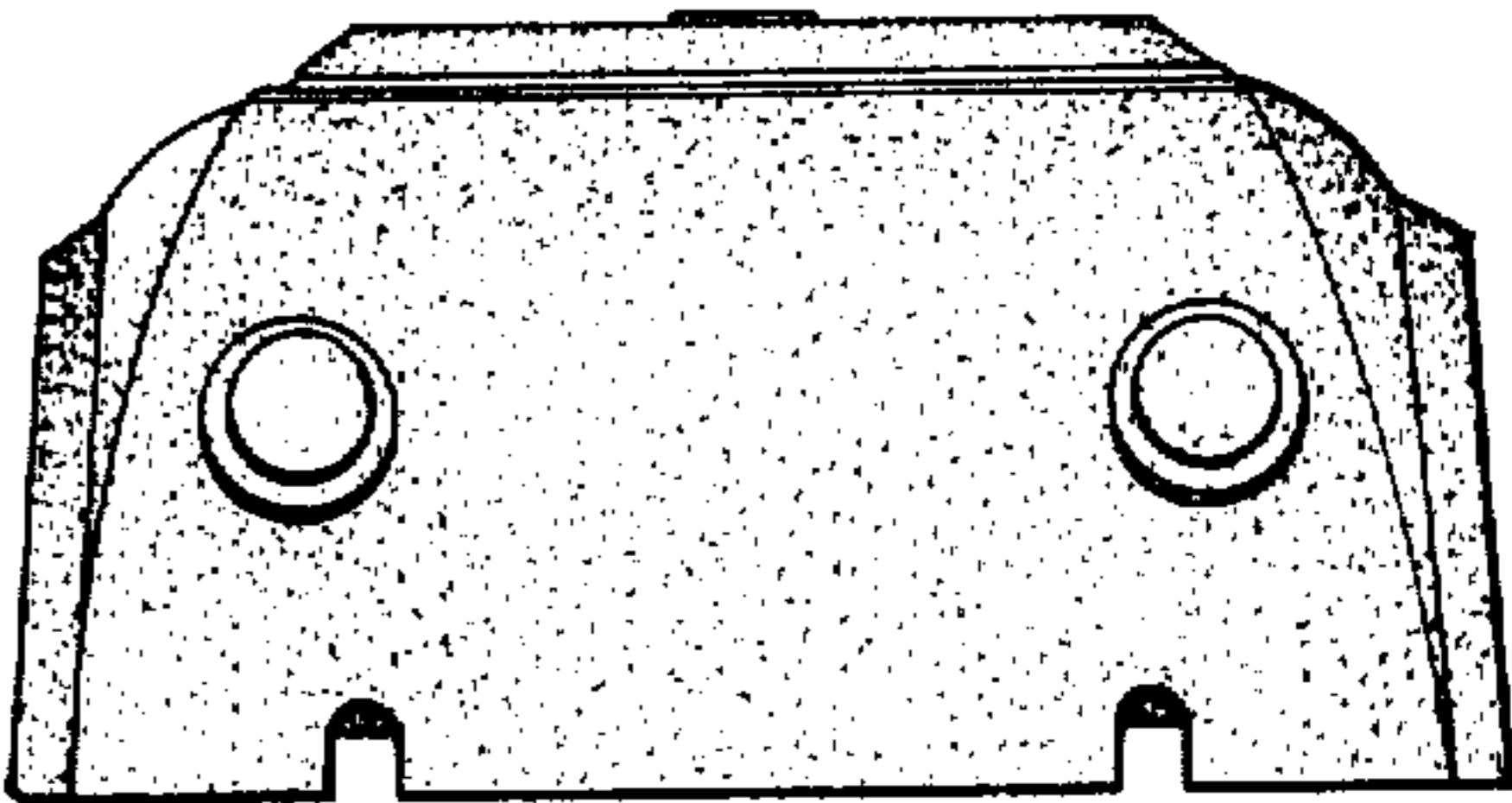

FIG 4

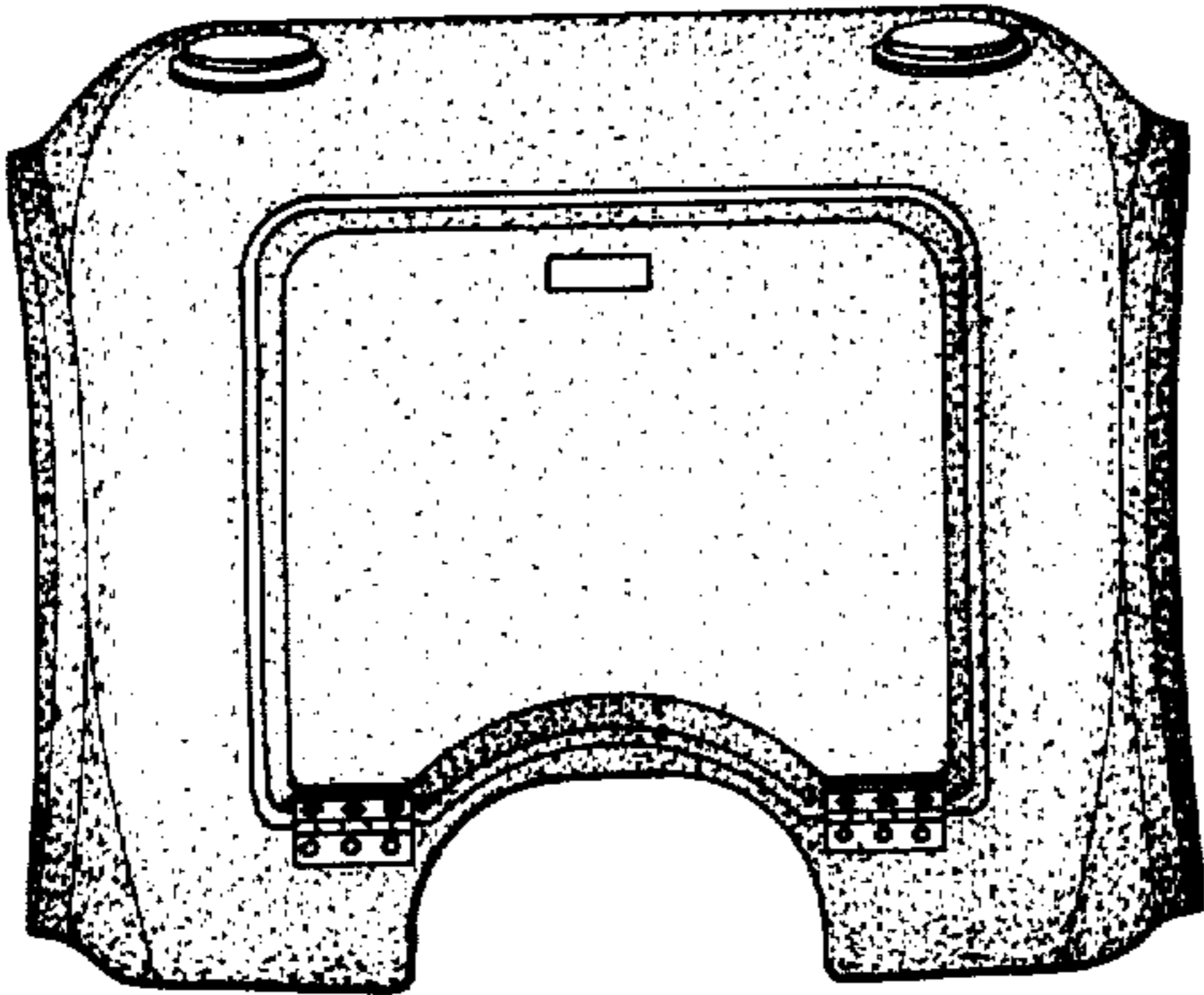

FIG 5

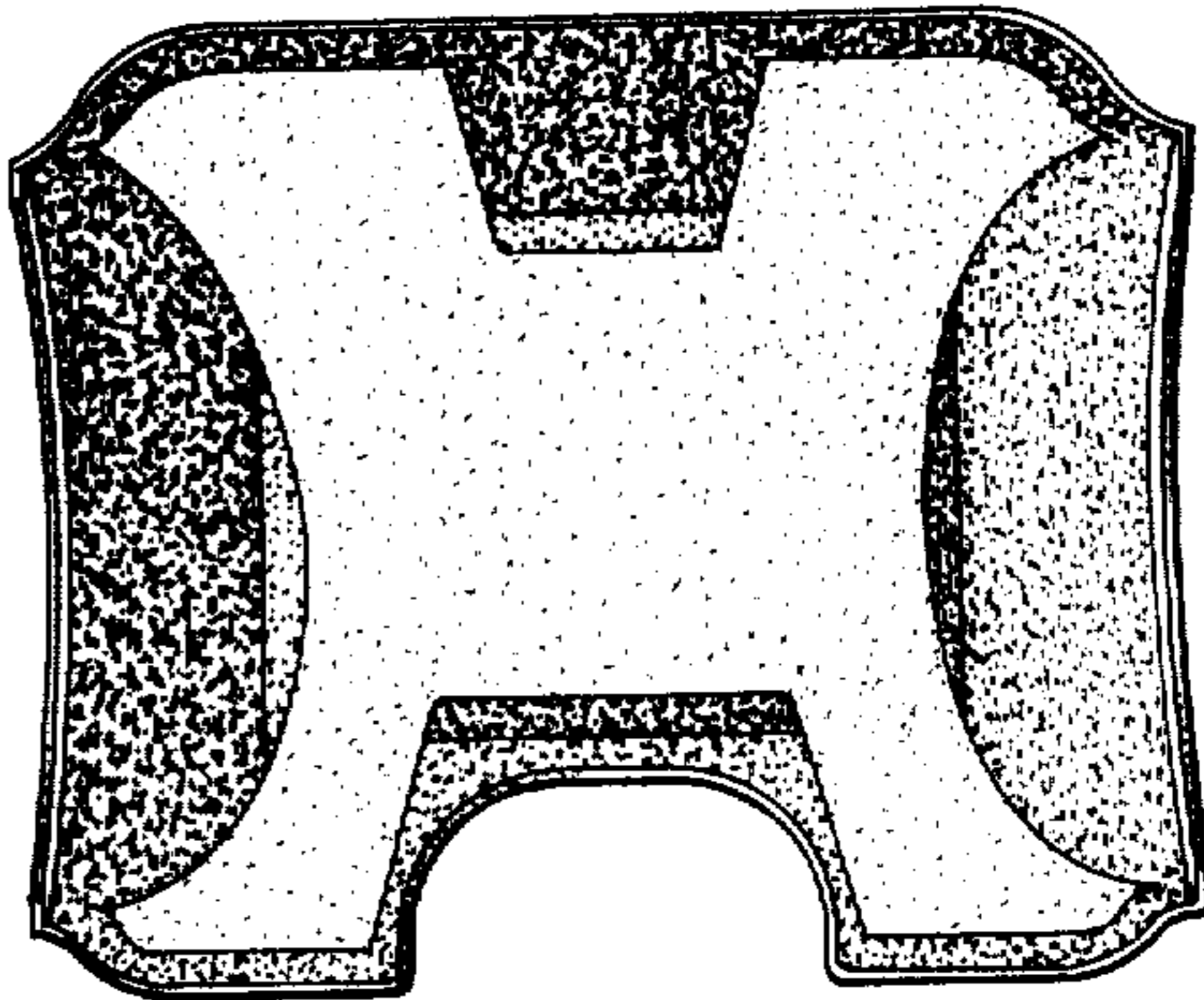

FIG 6