

[54] CONTROL UNIT FOR A COMBINED AUTOMOBILE CASSETTE PLAYER AND RADIO

[75] Inventors: John F. Castagna, Brooklyn; Ronald A. Emmerling, New City, both of N.Y.

[73] Assignee: Sparkomatic Corporation, Milford, Pa.

[\*] Notice: The portion of the term of this patent subsequent to Sep. 15, 1995, has been disclaimed.

[\*\*] Term: 14 Years

[21] Appl. No.: 85,035

[22] Filed: Oct. 15, 1979

[51] Int. Cl. .... D14-01; D14-03

[52] U.S. Cl. .... D14/10; D14/5; D14/7; D14/76

[58] Field of Search .... D14/1, 5-7, D14/10, 68, 70-76, 99

[56] References Cited

U.S. PATENT DOCUMENTS

D. 116,746 9/1939 Marholz ..... D14/76

OTHER PUBLICATIONS

Sanyo Supplement to 1-13-77, Home Furnishings Daily, p. 5, Item #FT875. Sanyo Supplement to Home Furnishings Daily, inside rear cover, Item #FT1876. Radio Shack Cat. #291, 1977 Fall Sale Cat., p. 5, "Car AM/FM Stereo 8-Track Player".

Primary Examiner—Jane E. Corrigan Attorney, Agent, or Firm—Mason, Fenwick & Lawrence

[57] CLAIM

The ornamental design for a control unit for a combined automobile cassette player and radio, as shown and described.

DESCRIPTION

FIG. 1 is a front, top and left side perspective view of a control unit for a combined automobile cassette player and radio showing our new design; FIG. 2 is a front elevational view; and FIG. 3 is a right side elevational view. The broken line structure forms no part of the claimed design and is included for illustrative purposes only. The rear of the control unit is conventional.

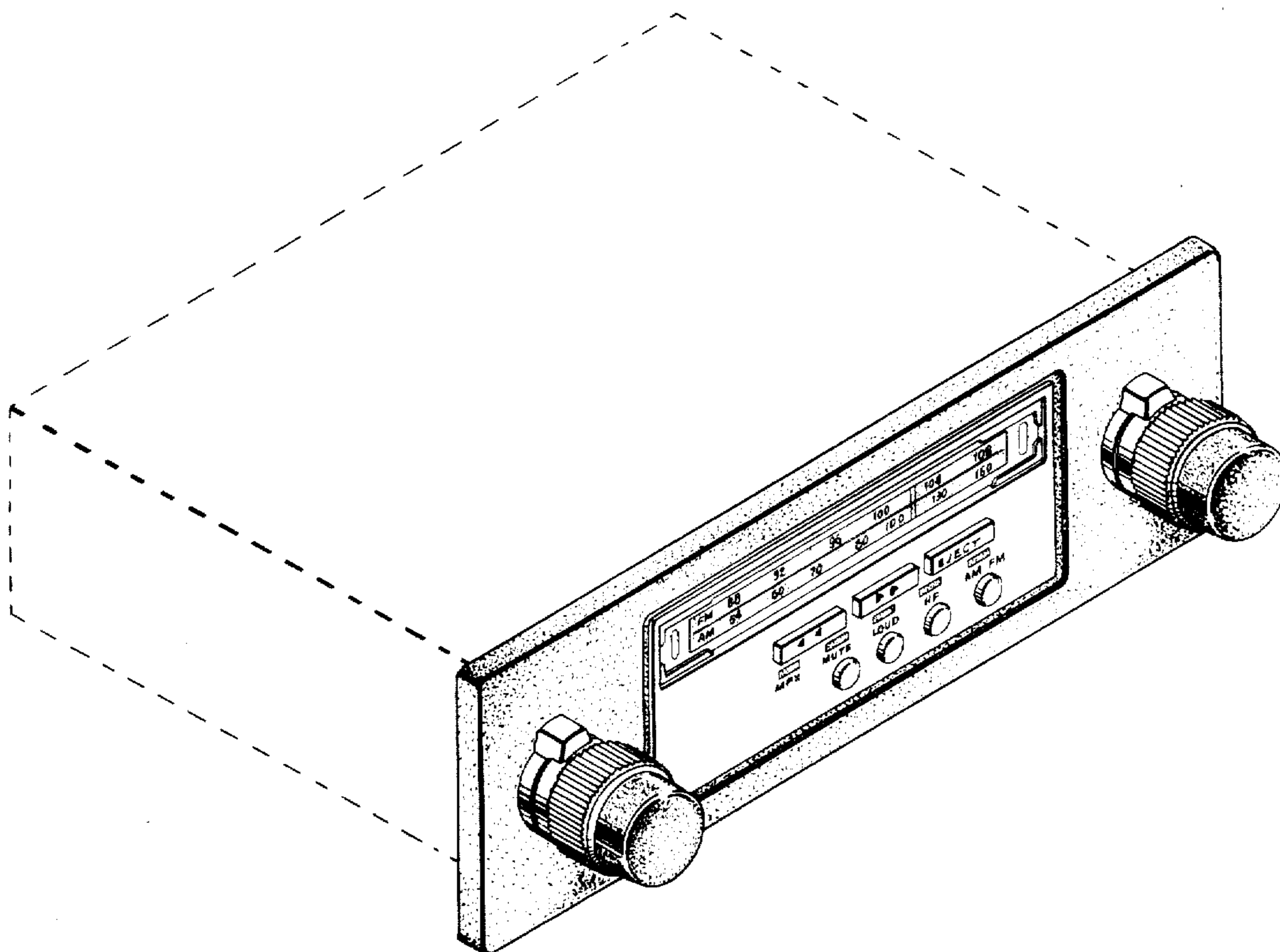

Fig-1

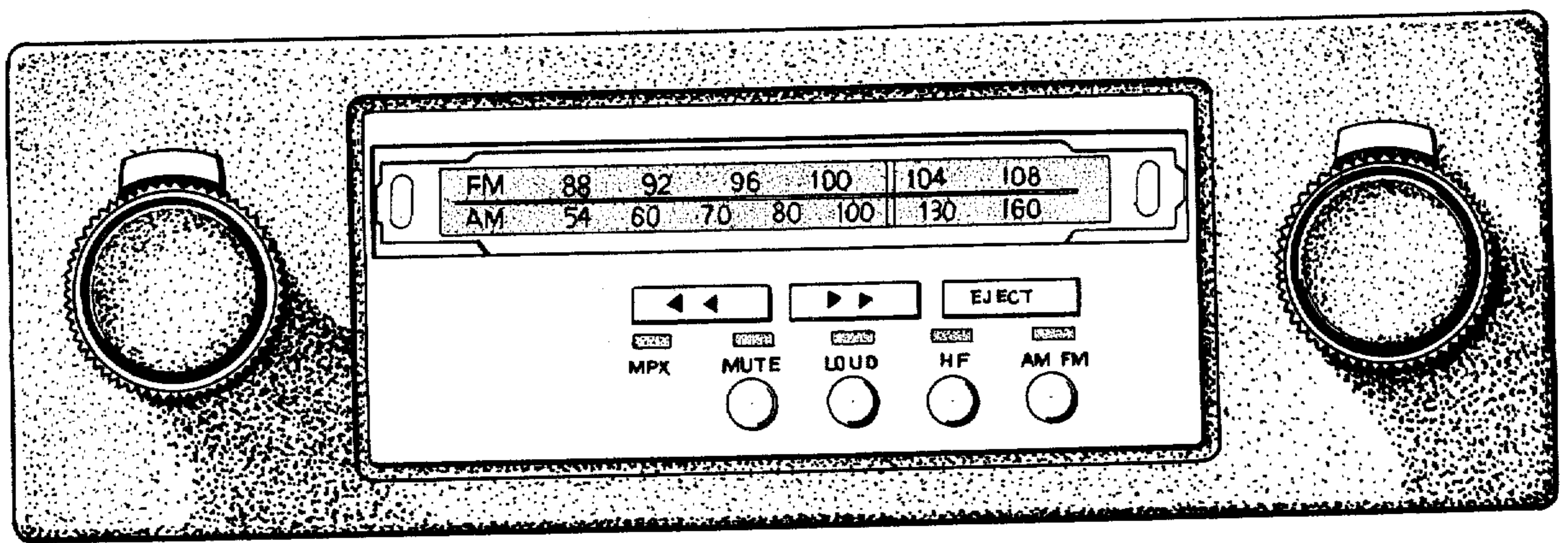
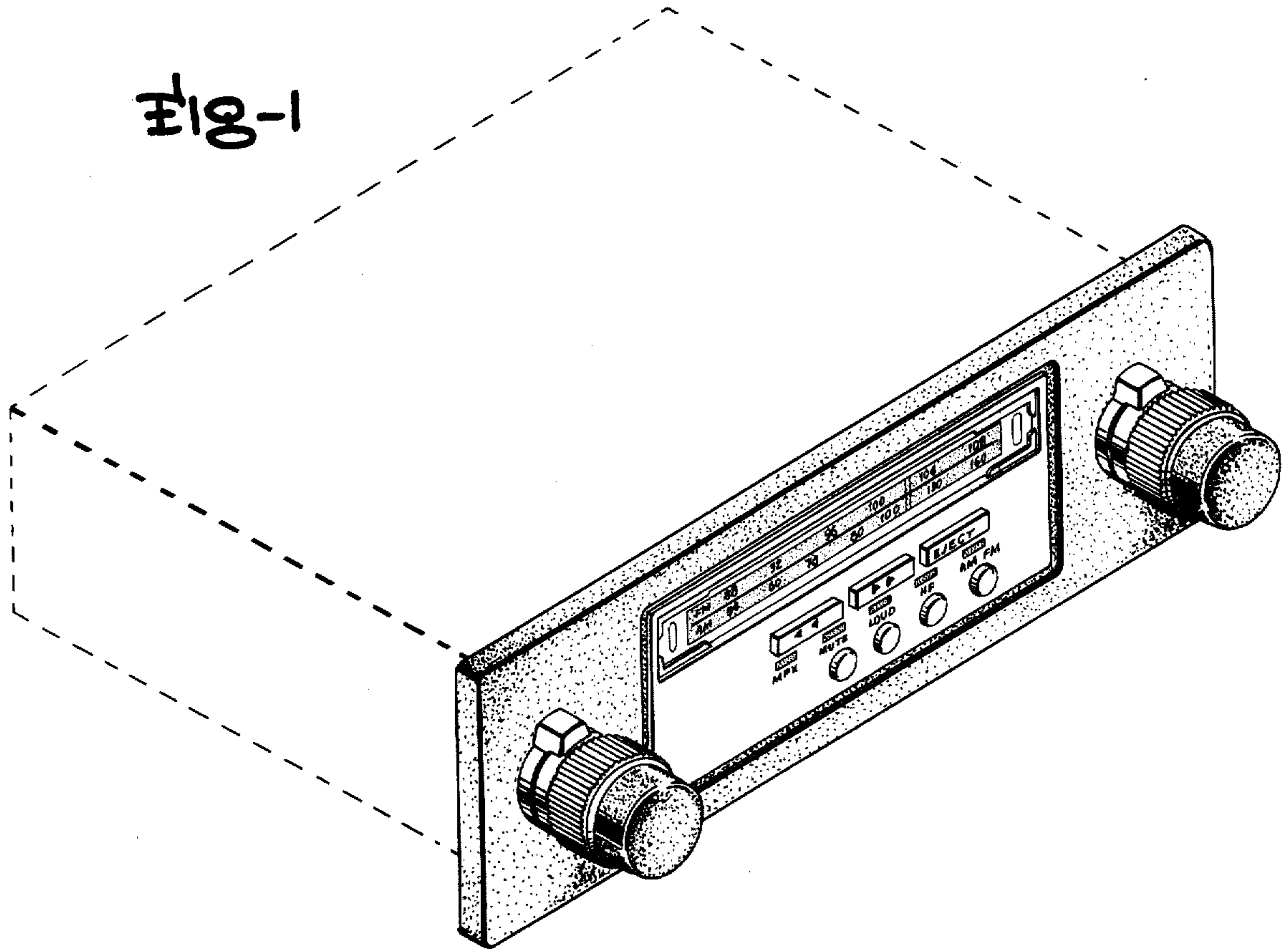

Fig-2

Fig-3

