

[54] SAFETY TROLLEY

[76] Inventor: John F. Miller, P.O. Box 277,
Howell, Mich. 48843

[**] Term: 14 Years

[21] Appl. No.: 20,661

[22] Filed: Mar. 15, 1979

[51] Int. Cl. D12-05
[52] U.S. Cl. D34/35
[58] Field of Search D12/60, 54; D8/373;
105/150, 152, 154, 155; 104/93

[56]

References Cited

U.S. PATENT DOCUMENTS

D. 242,015 10/1976 Busche et al. D8/373
D. 242,016 10/1976 Busche et al. D8/373
876,486 1/1908 Pfaffenbach 105/152

Primary Examiner—James M. Gandy

Attorney, Agent, or Firm—Burton, Parker & Schramm

[57]

CLAIM

The ornamental design for a safety trolley, as shown.

DESCRIPTION

FIG. 1 is a front elevational view of a safety trolley showing my new design;
FIG. 2 is a rear elevational view thereof;
FIG. 3 is a top plan view thereof;
FIG. 4 is a side elevational view thereof; and
FIG. 5 is a bottom plan view thereof.

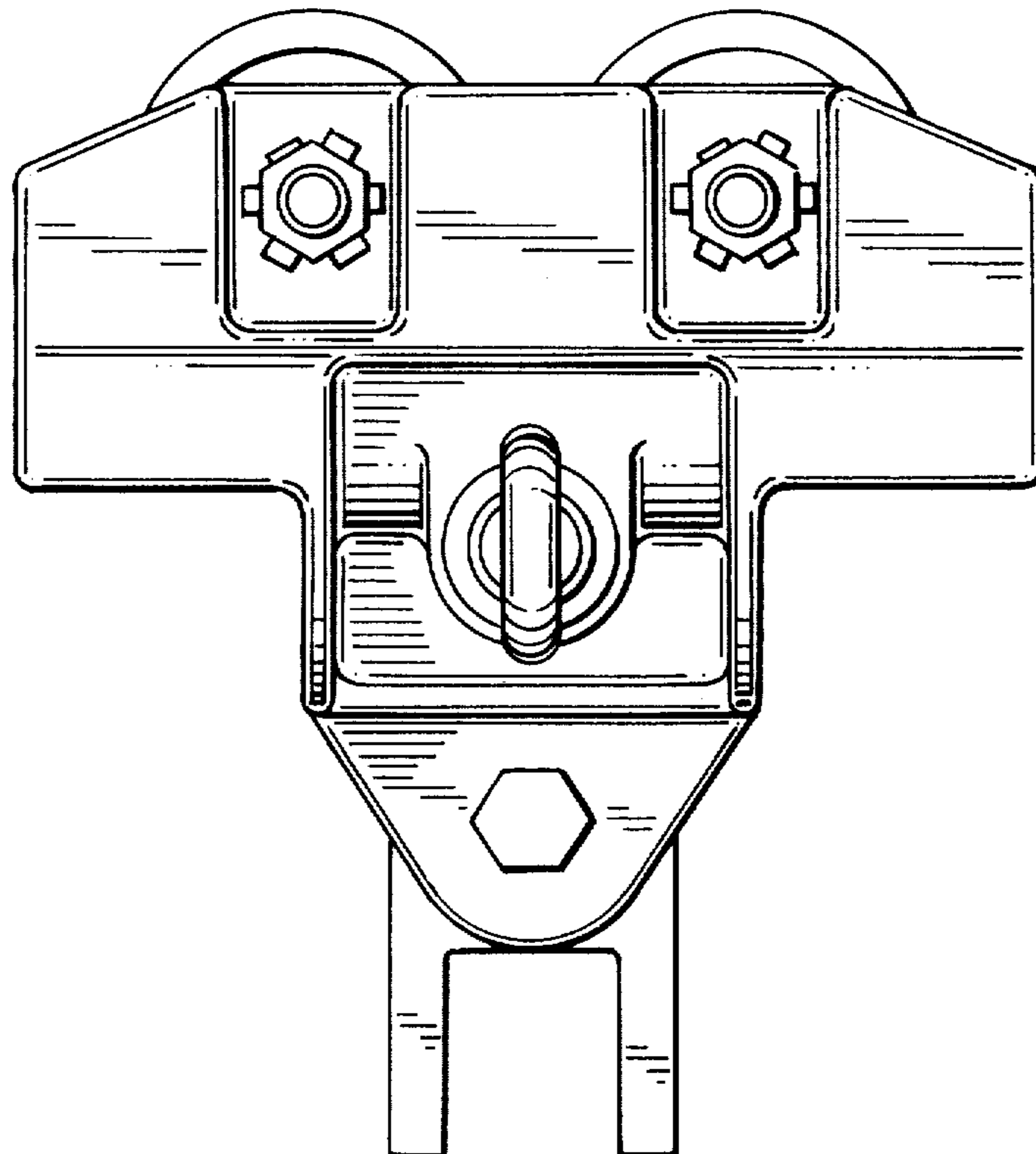

FIG. 1

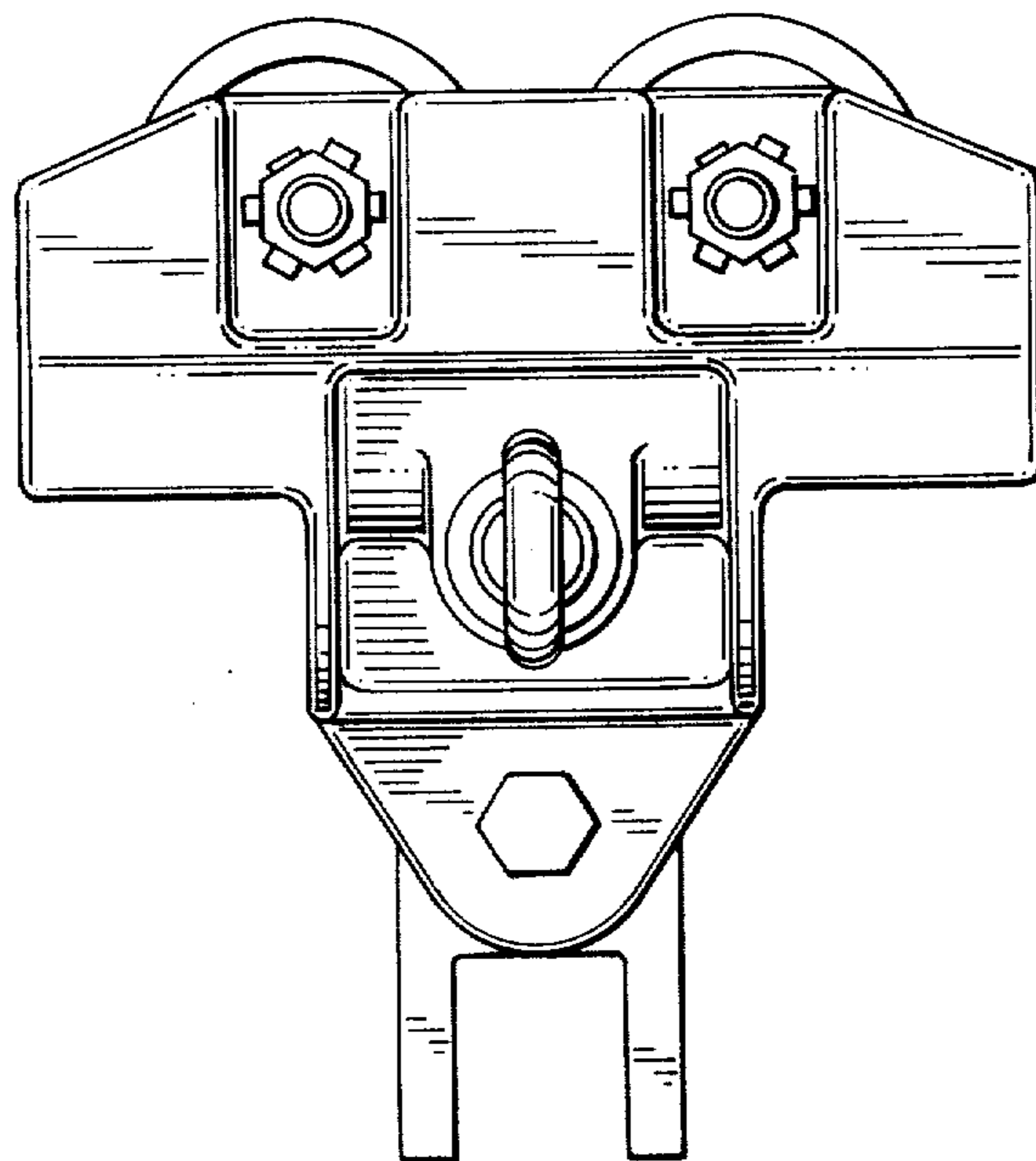

FIG. 2

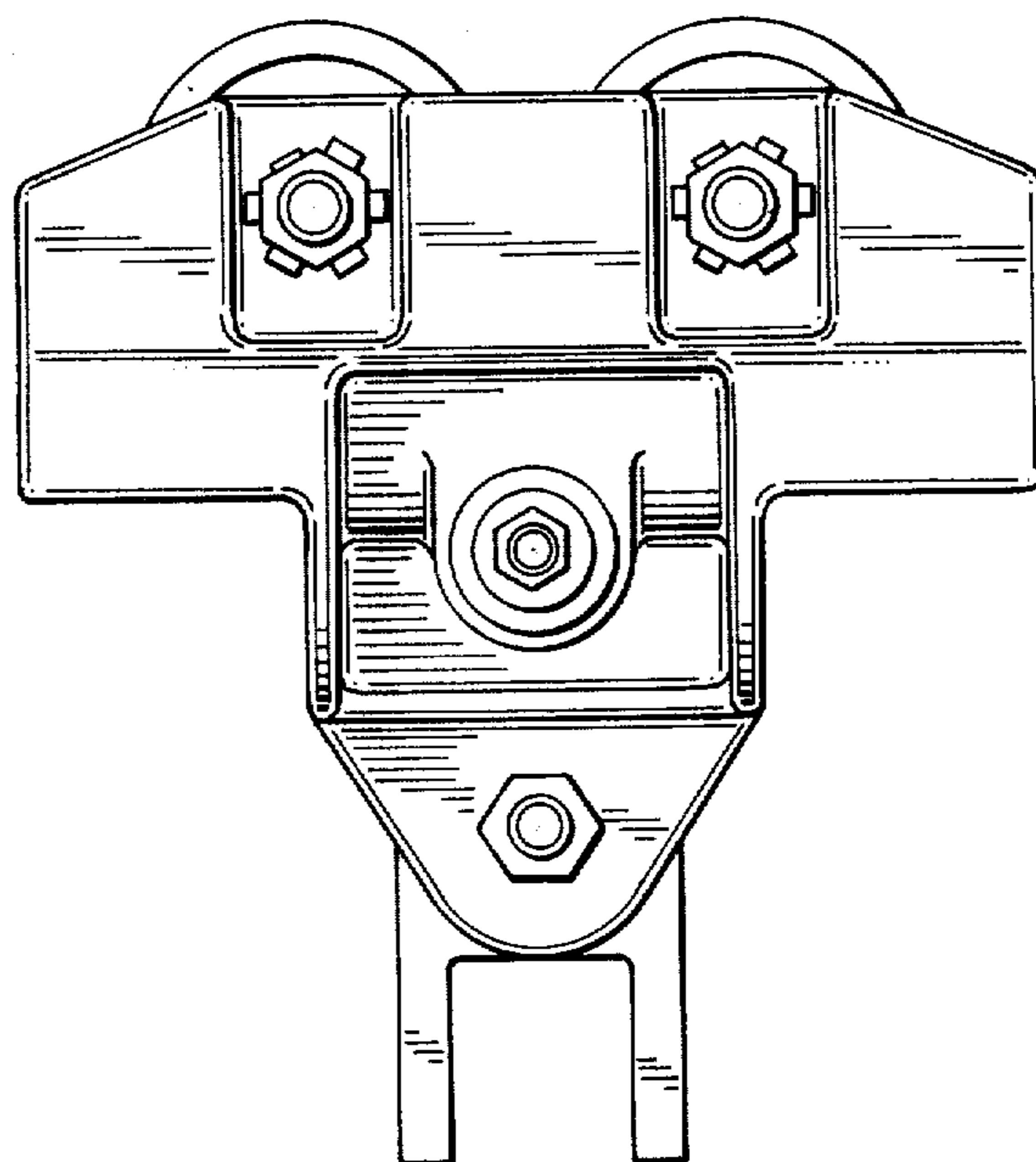

FIG. 3

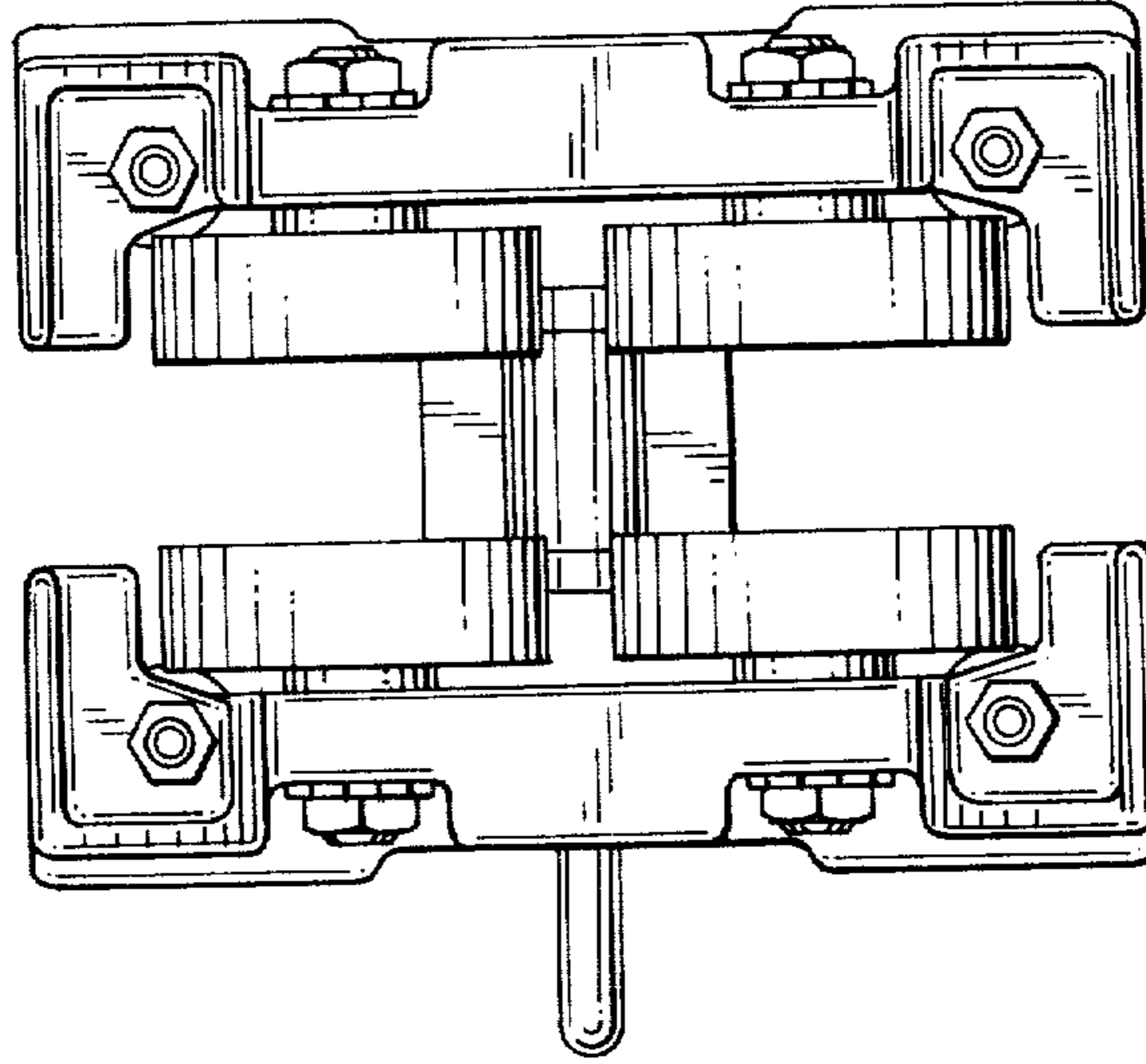

FIG. 4

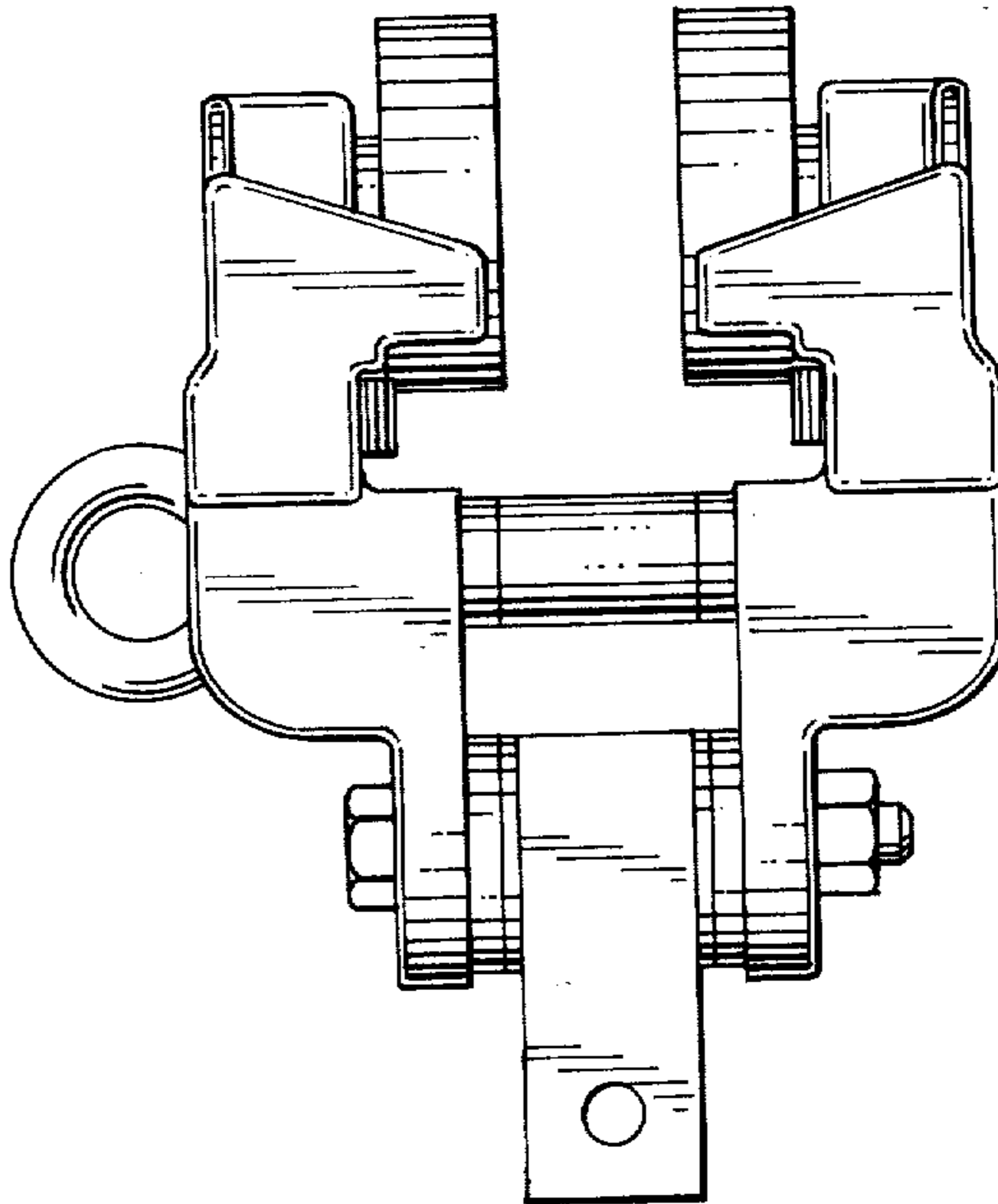

FIG. 5

