

[54] WHEEL

[75] Inventors: **Russell O. Blanchard**, Marshall;
Joseph Guzek, Lansing; **Donald A. Matt**, Bath, all of Mich.

[73] Assignee: **Motor Wheel Corporation**, Lansing, Mich.

[**] Term: **14 Years**

[21] Appl. No.: **4,346**

[22] Filed: **Jan. 18, 1979**

[51] Int. Cl. **D12-16**

[52] U.S. Cl. **D12/209**

[58] Field of Search **D12/209-211;**
301/63 R, 64 R, 64 SD, 65, 66

[56] **References Cited**

U.S. PATENT DOCUMENTS

D. 206,873 2/1967 Reid D12/211
D. 224,006 6/1972 Chandler et al. D12/209

OTHER PUBLICATIONS

Motor Trend, 4/65, p. 26, Wheel, top right side of page.

Primary Examiner—James M. Gandy
Attorney, Agent, or Firm—Barnes, Kisselle, Raisch & Choate

[57] **CLAIM**

The ornamental design for a wheel, substantially as shown and described.

DESCRIPTION

FIG. 1 is a front perspective view of a wheel showing our new design.

FIG. 2 is a front elevational view thereof.

FIG. 3 is a sectional view thereof taken on line 3—3 of FIG. 2.

FIG. 4 is a rear elevational view thereof.

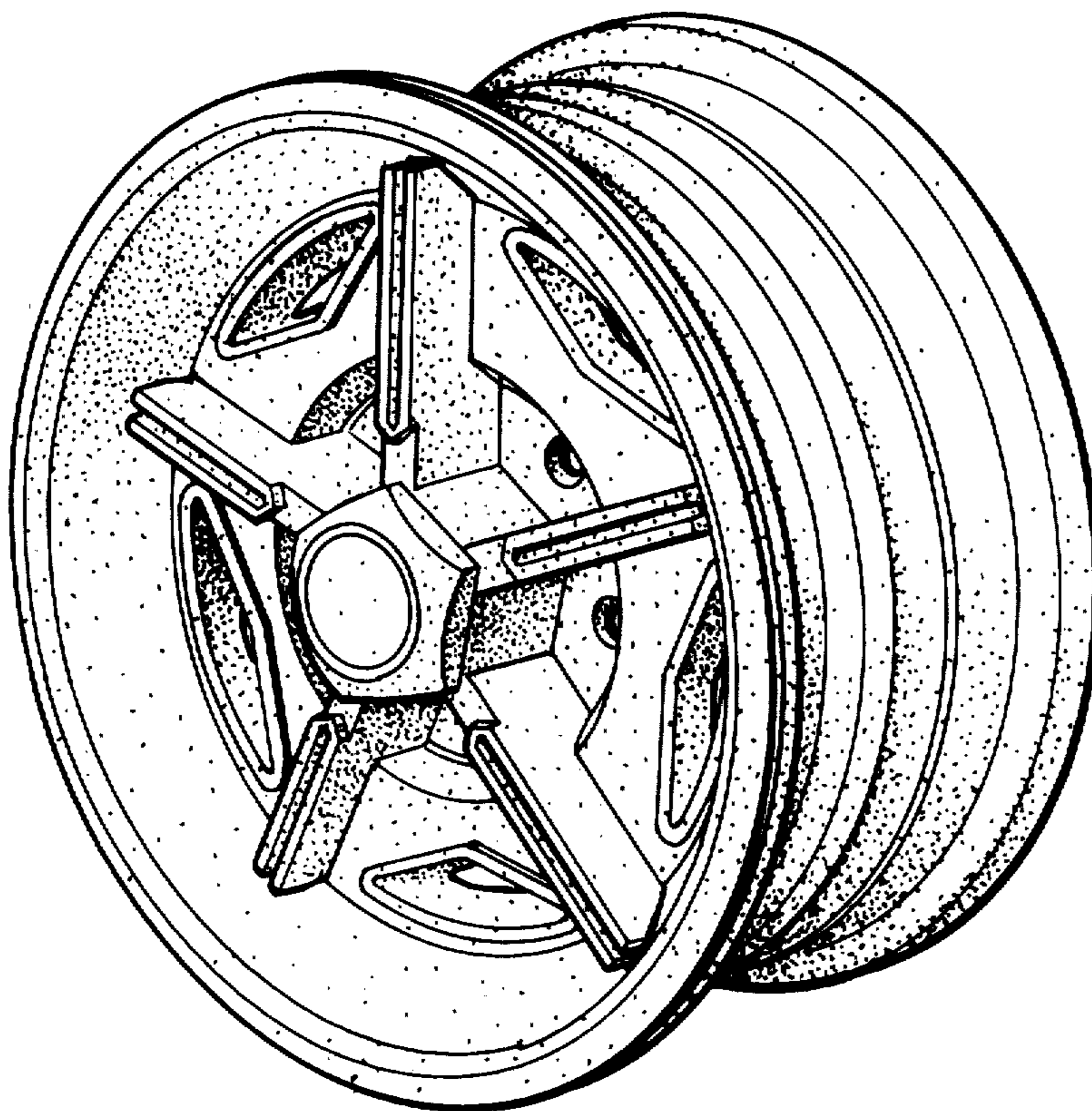

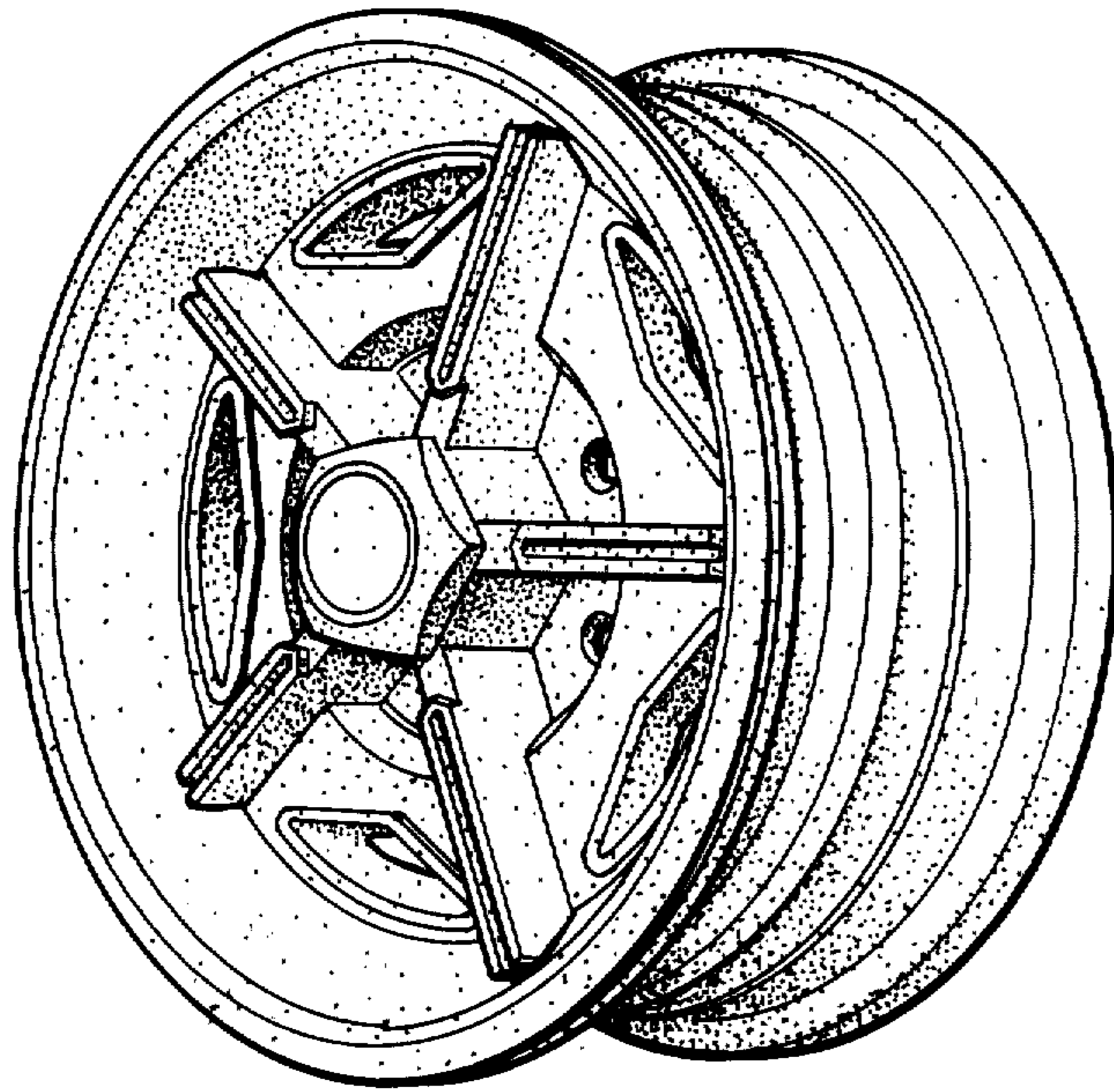

FIG. 1

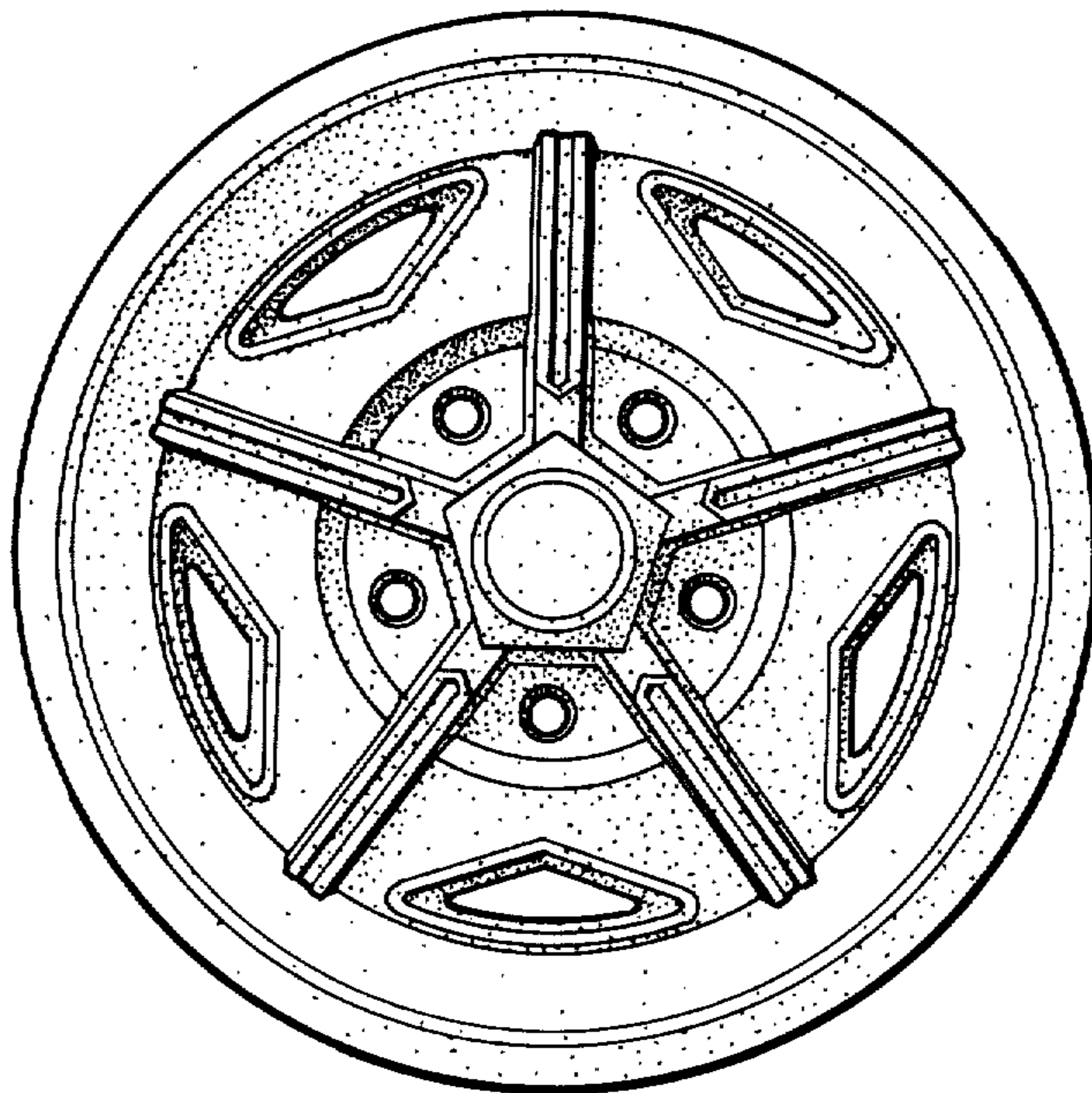
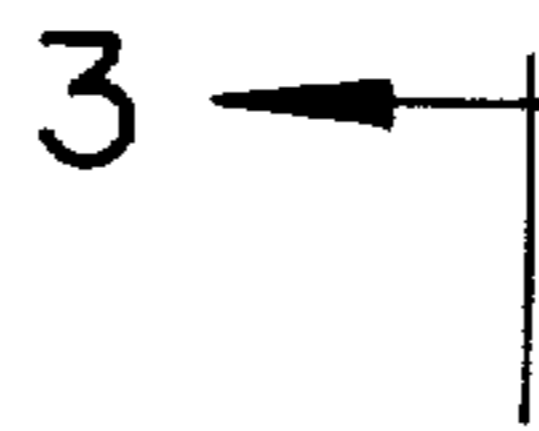
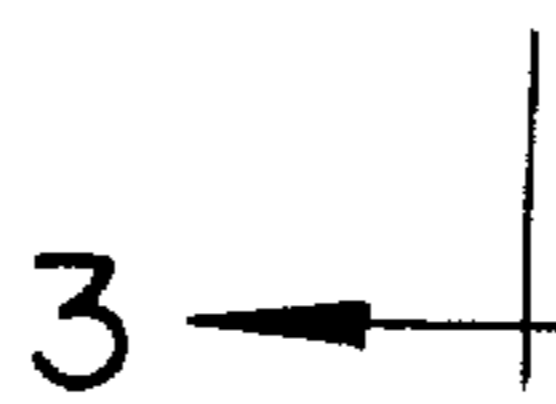

FIG. 2



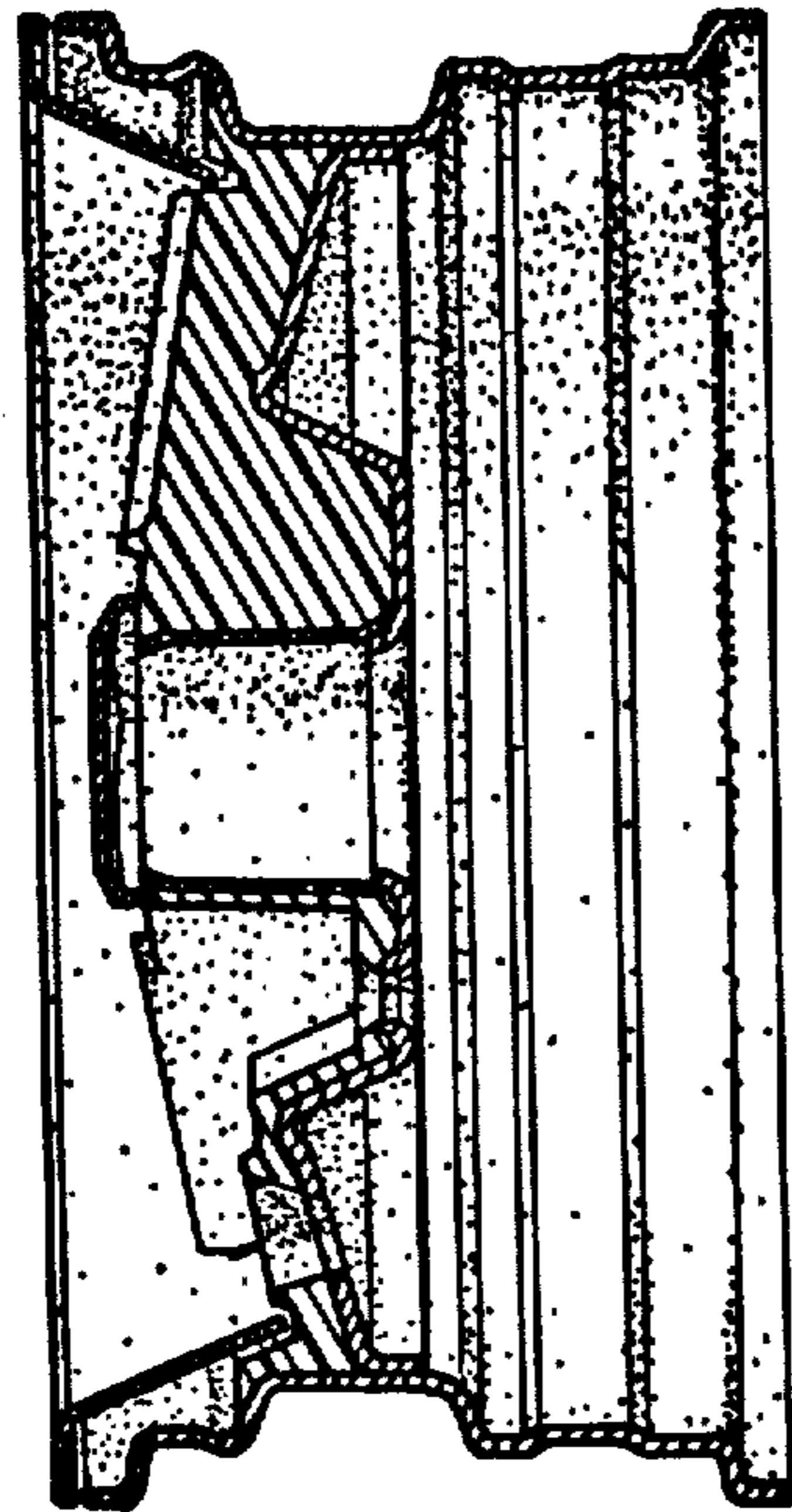

FIG. 3

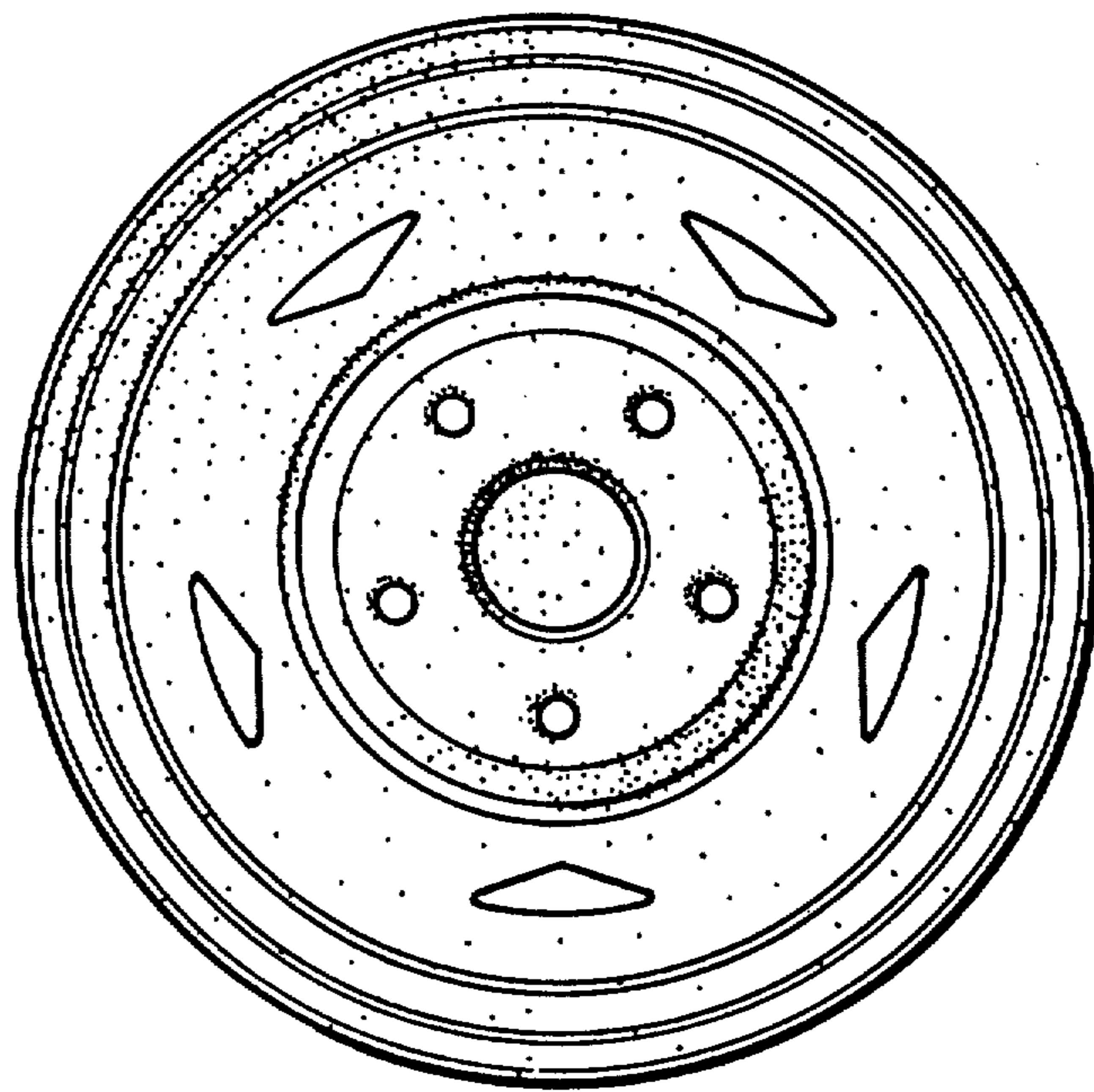

FIG. 4