

[54] AIRPLANE
[75] Inventors: **Gottfried O. Friebel**, Bellevue;
Robert M. Kulfan, Kirkland, both of Wash.

1,743,284 1/1930 Refsland 244/35 R
1,859,044 5/1932 Moe 244/13
2,589,994 3/1952 Custer 244/35 R
3,152,775 10/1964 Boyd 244/13
3,625,459 12/1971 Brown 244/35 R X

[73] Assignee: **The Boeing Company**, Seattle, Wash.

Primary Examiner—Alan P. Douglas
Attorney, Agent, or Firm—Ronald E. Suter; Bernard A. Donahue

[**] Term: **14 Years**

[21] Appl. No.: **65,794**

[57] **CLAIM**

[22] Filed: **Aug. 13, 1979**

The ornamental design for an airplane, as shown and described above.

[51] Int. Cl. **D12-07**

[52] U.S. Cl. **D12/341**

[58] Field of Search **D12/341; 244/198, 13, 244/35 R**

DESCRIPTION

FIG. 1 is a lower frontal side perspective view of an airplane depicting an example of our new design; FIG. 2 is a front elevational view thereof; FIG. 3 is a side elevational view thereof; FIG. 4 is a top plan view thereof; FIG. 5 is a rear elevational view thereof; and FIG. 6 is a bottom plan view thereof.

[56] **References Cited**
U.S. PATENT DOCUMENTS

D. 175,342 11/1955 Gibbons et al. D12/341
1,063,805 6/1913 Krause 244/198

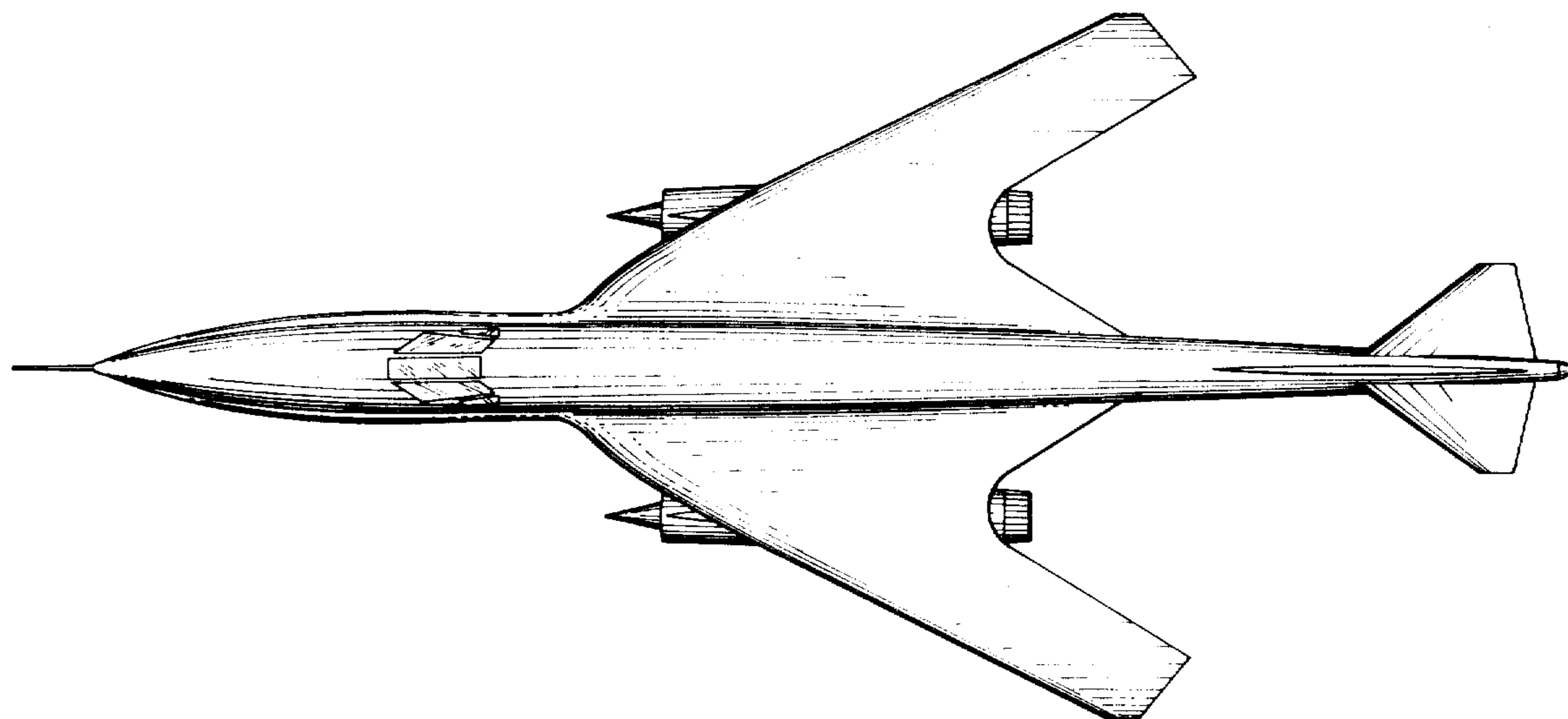
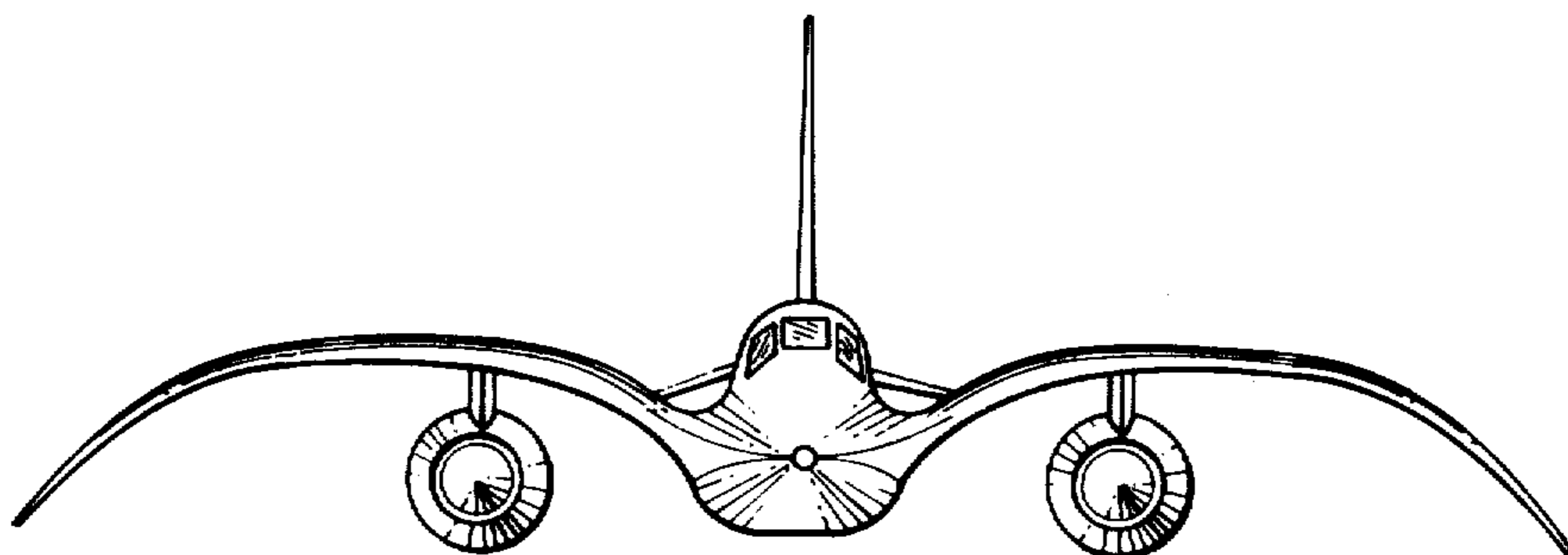

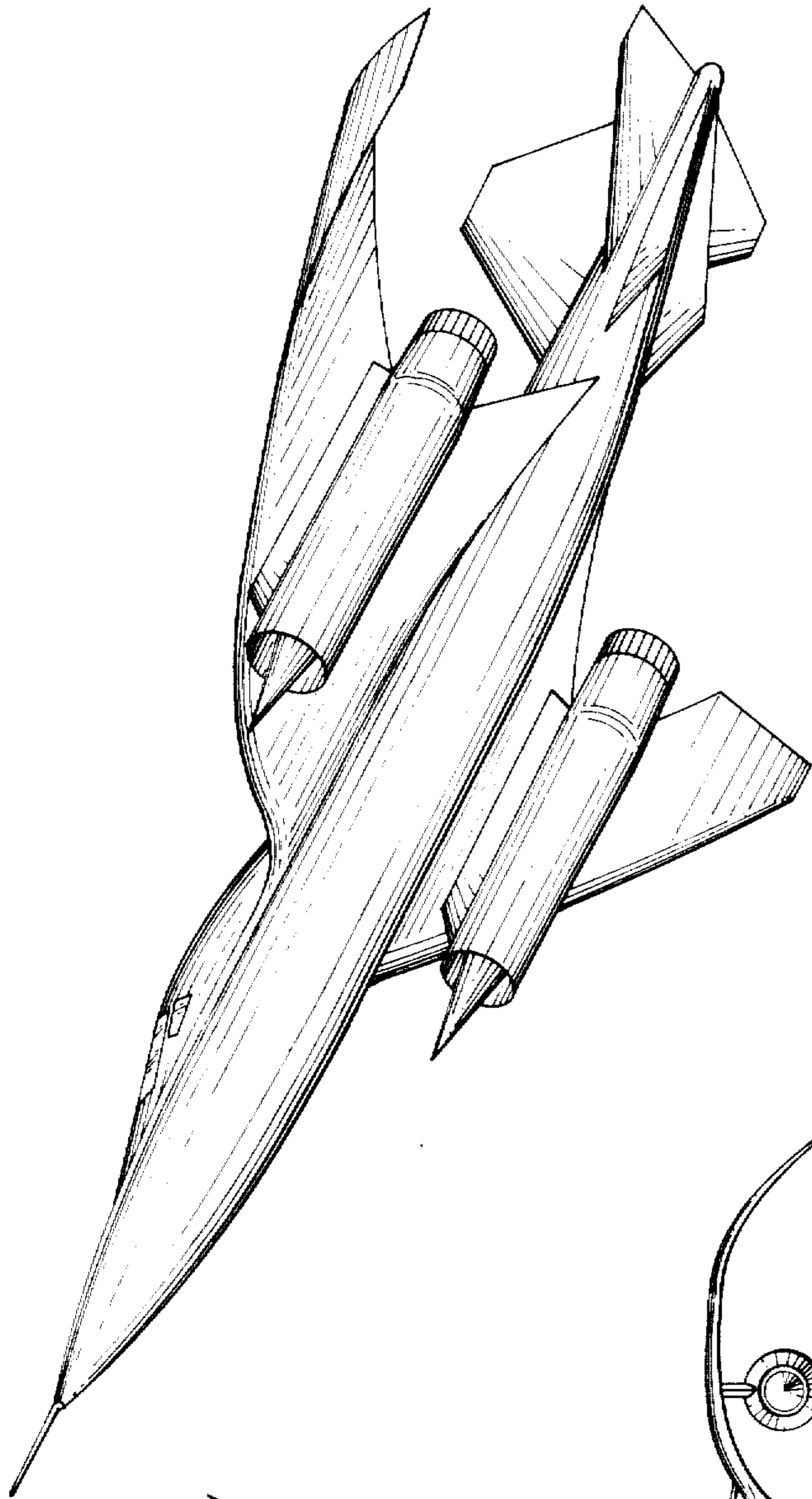

Fig. 1

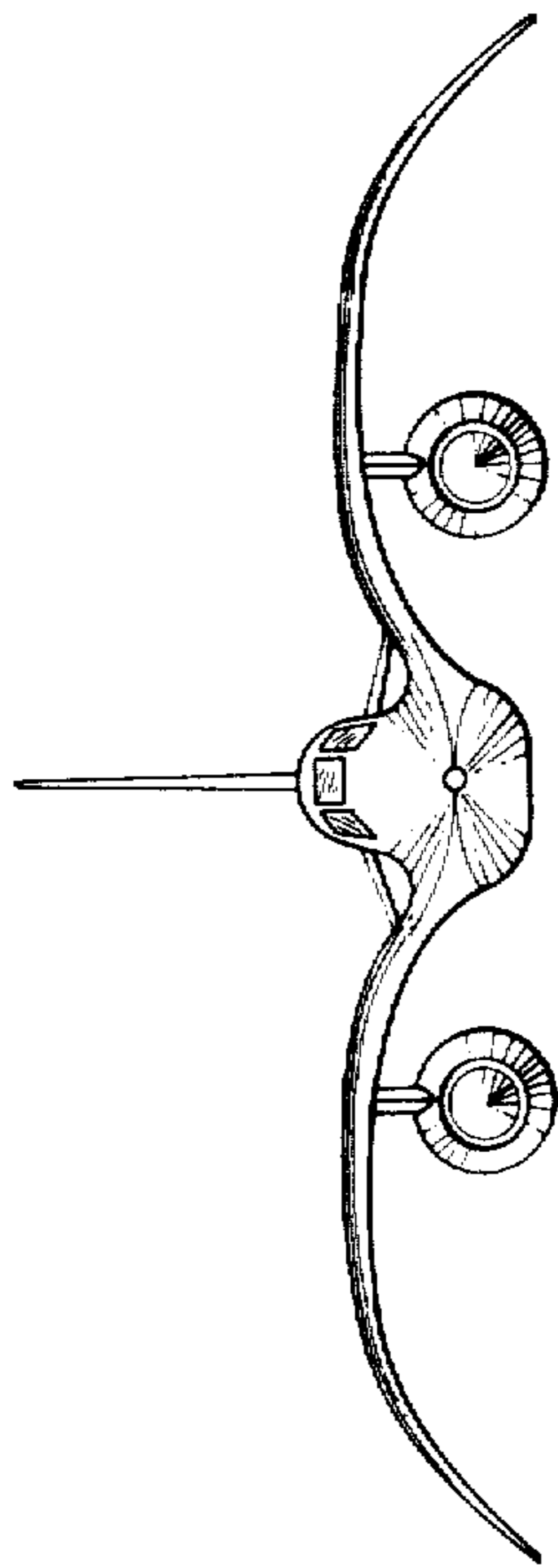

Fig. 2



Fig. 3

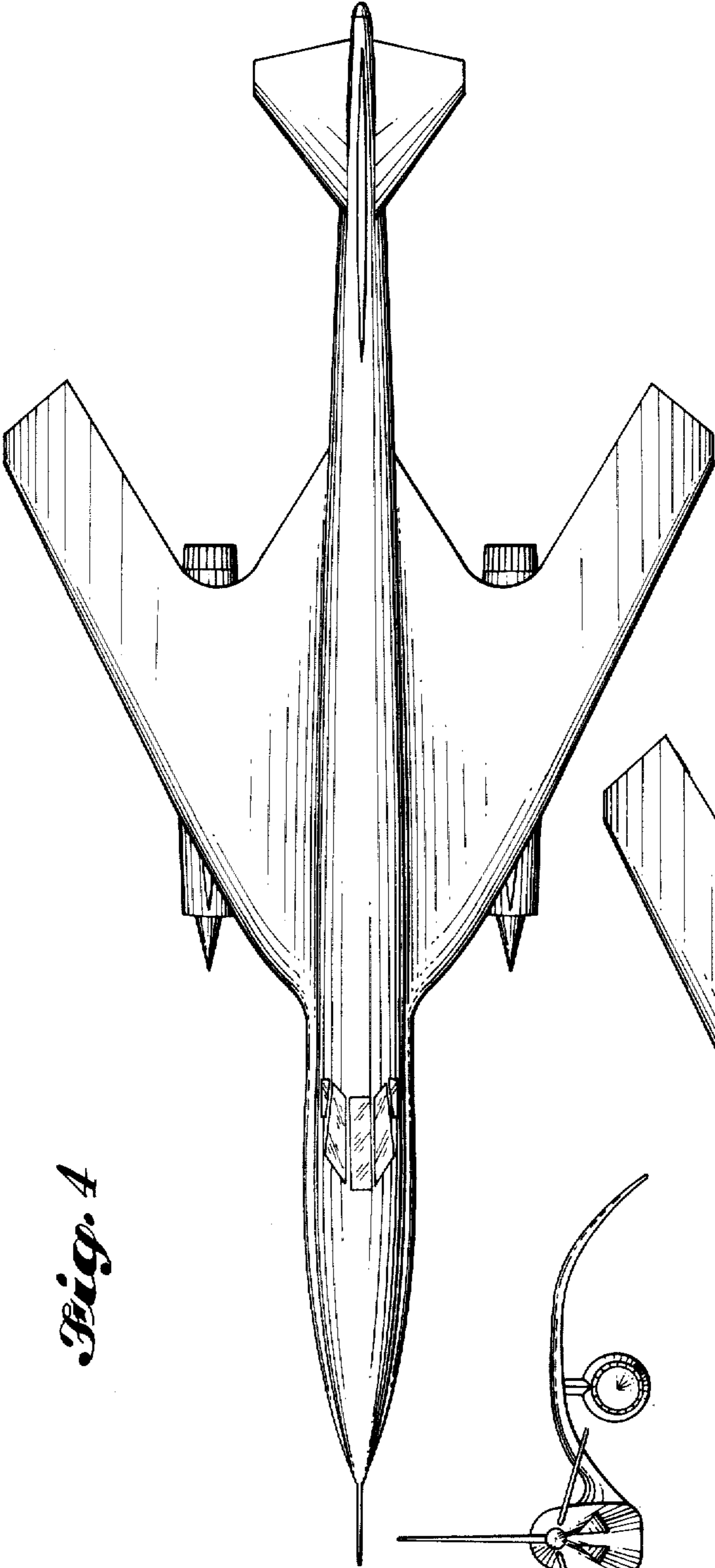

Fig. 4

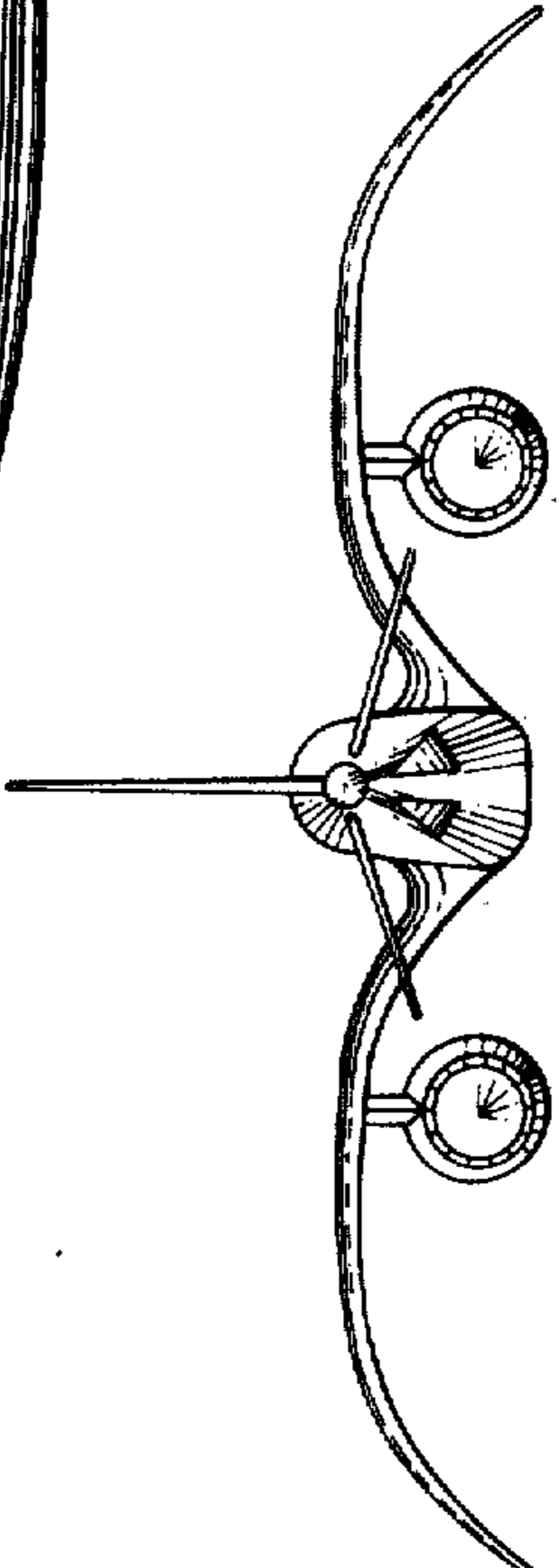

Fig. 5

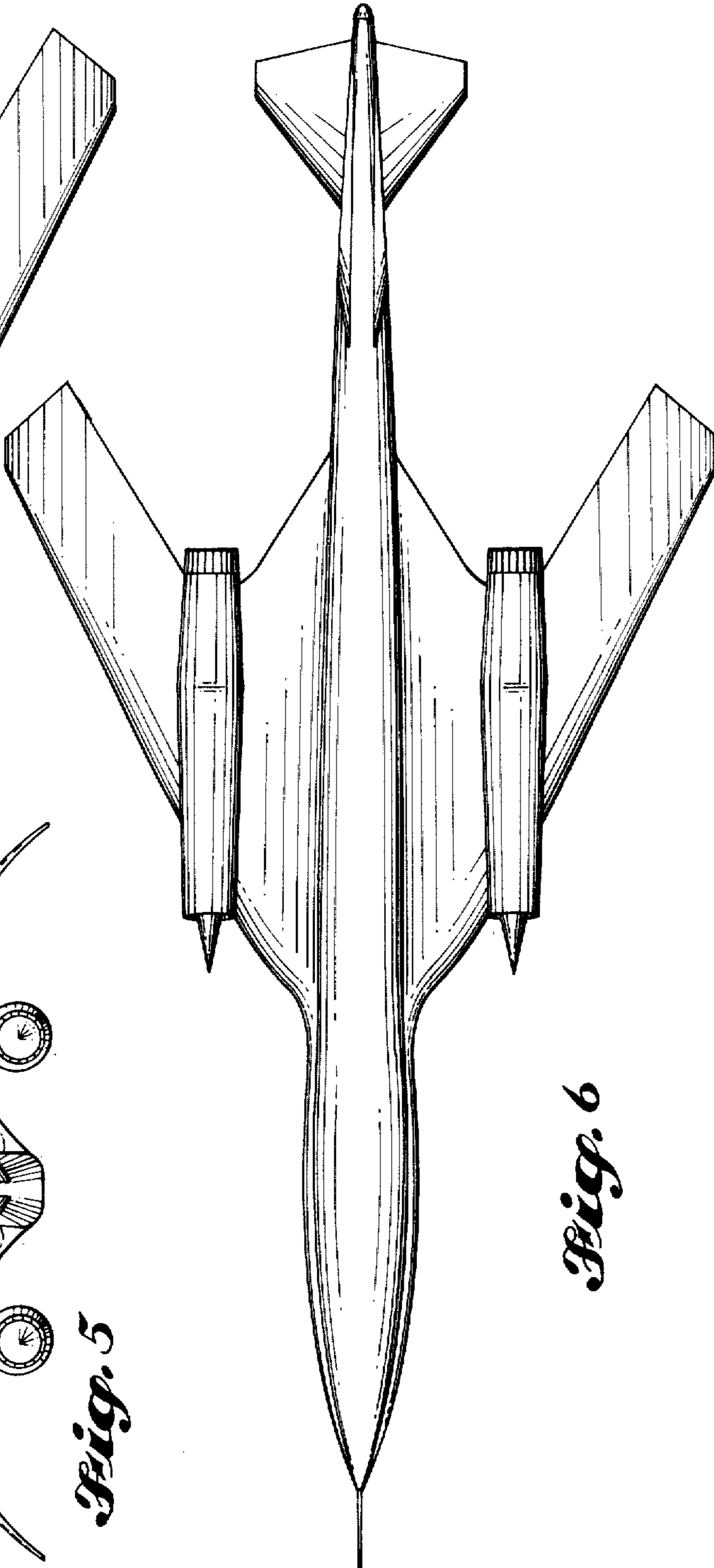

Fig. 6