

[54] MOTOR BOAT

[75] Inventor: Daryl G. Watson, Stanwood, Wash.

[73] Assignee: Bayliner Marine Corporation, Arlington, Wash.

[**] Term: 14 Years

[21] Appl. No.: 63,196

[22] Filed: Aug. 2, 1979

[51] Int. Cl. D12-06

[52] U.S. Cl. D12/314

[58] Field of Search D12/315, 300

[56] References Cited

U.S. PATENT DOCUMENTS

D. 257,558 11/1980 Arima D12/315

OTHER PUBLICATIONS

Sea, Aug. 1978, p. 43, Sea Ray 300 Boat on page.

Century Boat Company, 1977 Brochure, p. 5, Cortez 230 Boat on page.

Primary Examiner—Alan P. Douglas
Attorney, Agent, or Firm—Seed, Berry, Vernon & Baynham

[57] CLAIM

The ornamental design for a motor boat, as shown.

DESCRIPTION

FIG. 1 is a rear perspective view of the motor boat embodying my design;

FIG. 2 is a side elevation view of the motor boat of FIG. 1;

FIG. 3 is a top plan view of the motor boat of FIG. 1;

FIG. 4 is a bottom plan view of the motor boat of FIG. 1;

FIG. 5 is a front elevation view of the motor boat of FIG. 1; and

FIG. 6 is a rear elevation view of the motor boat of FIG. 1.

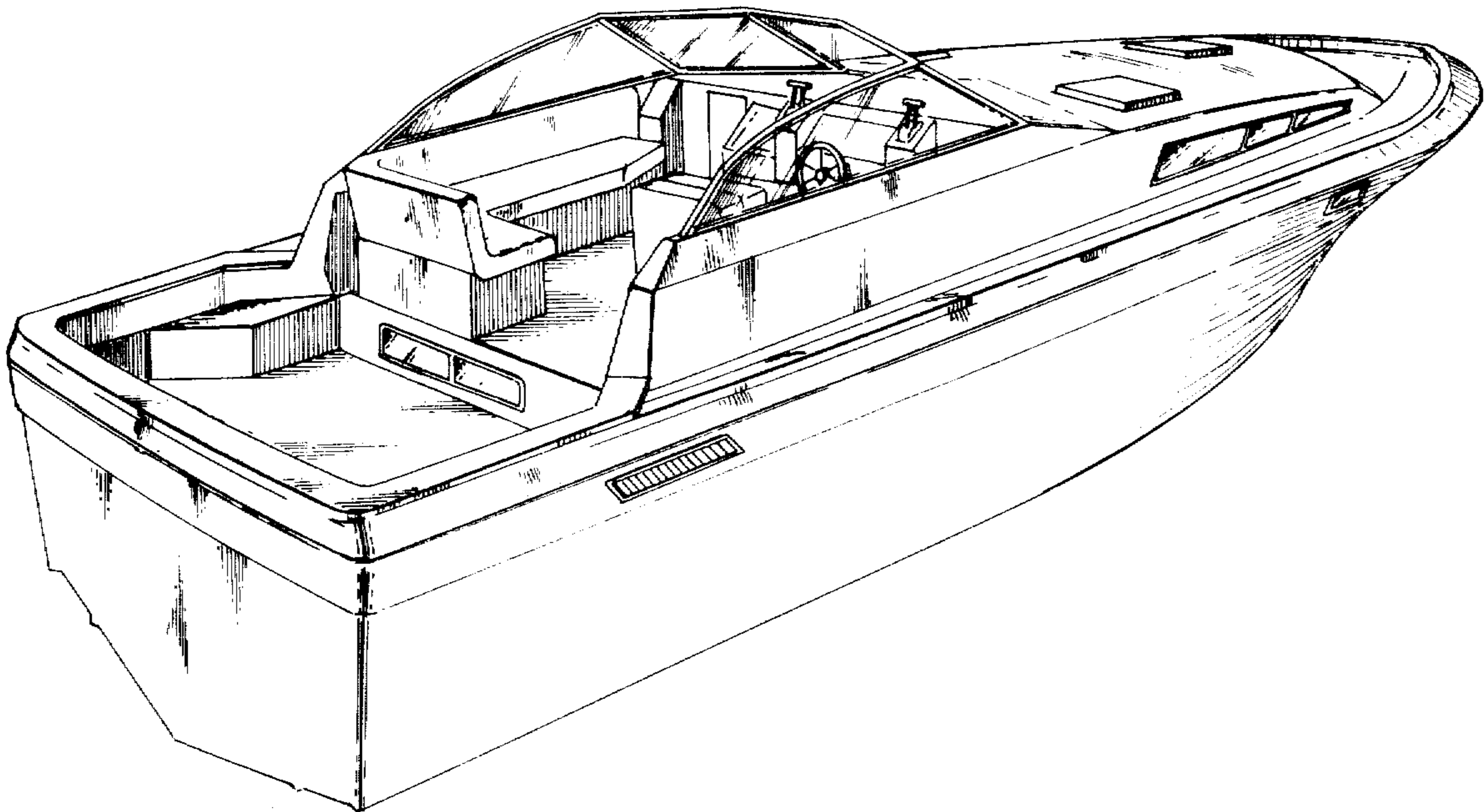

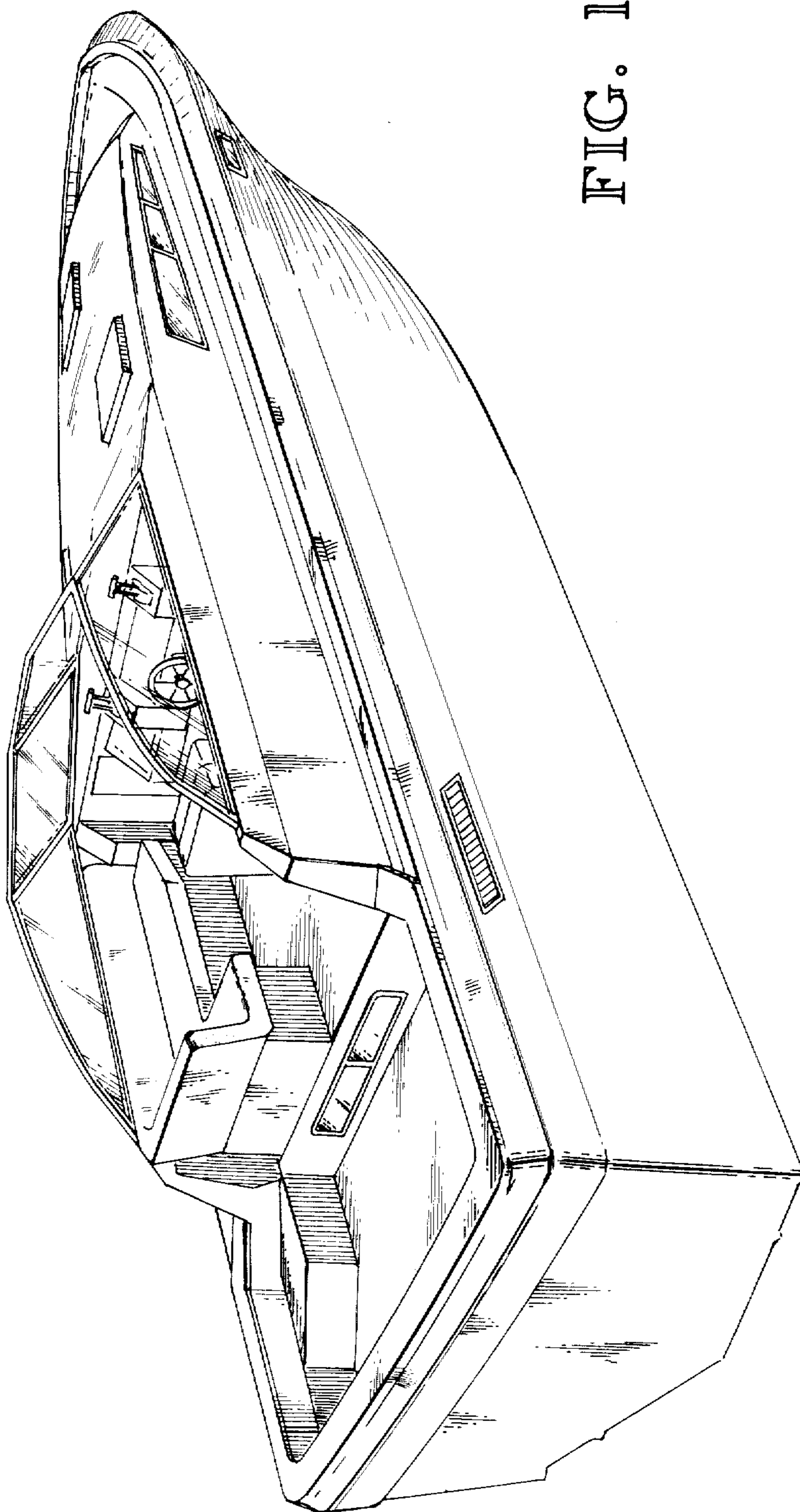

FIG. 1

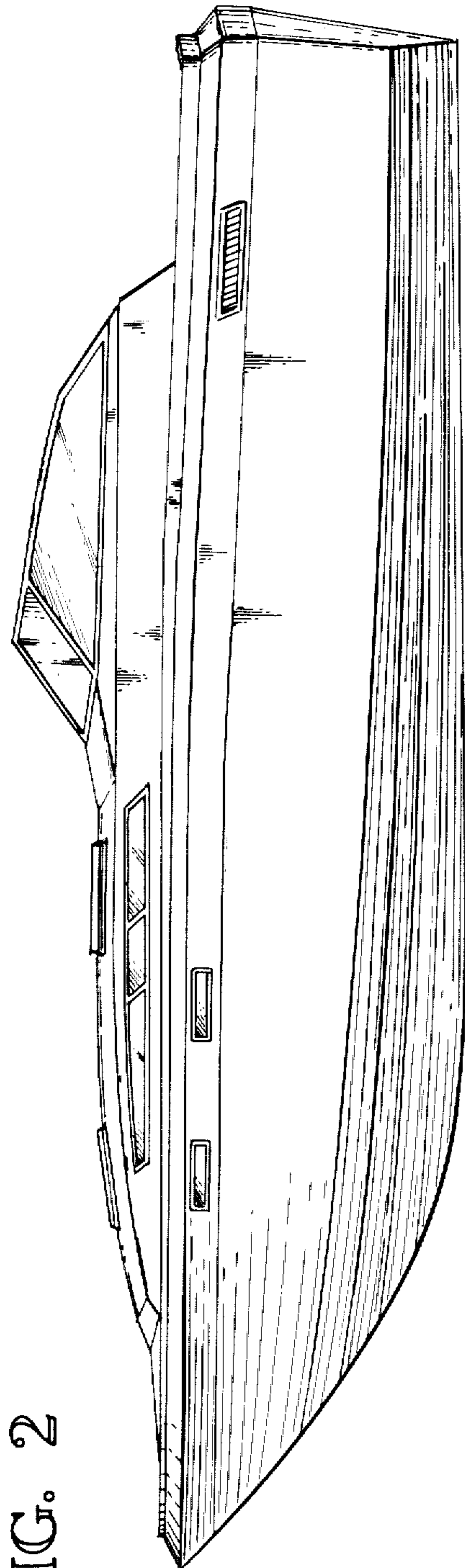

FIG. 2

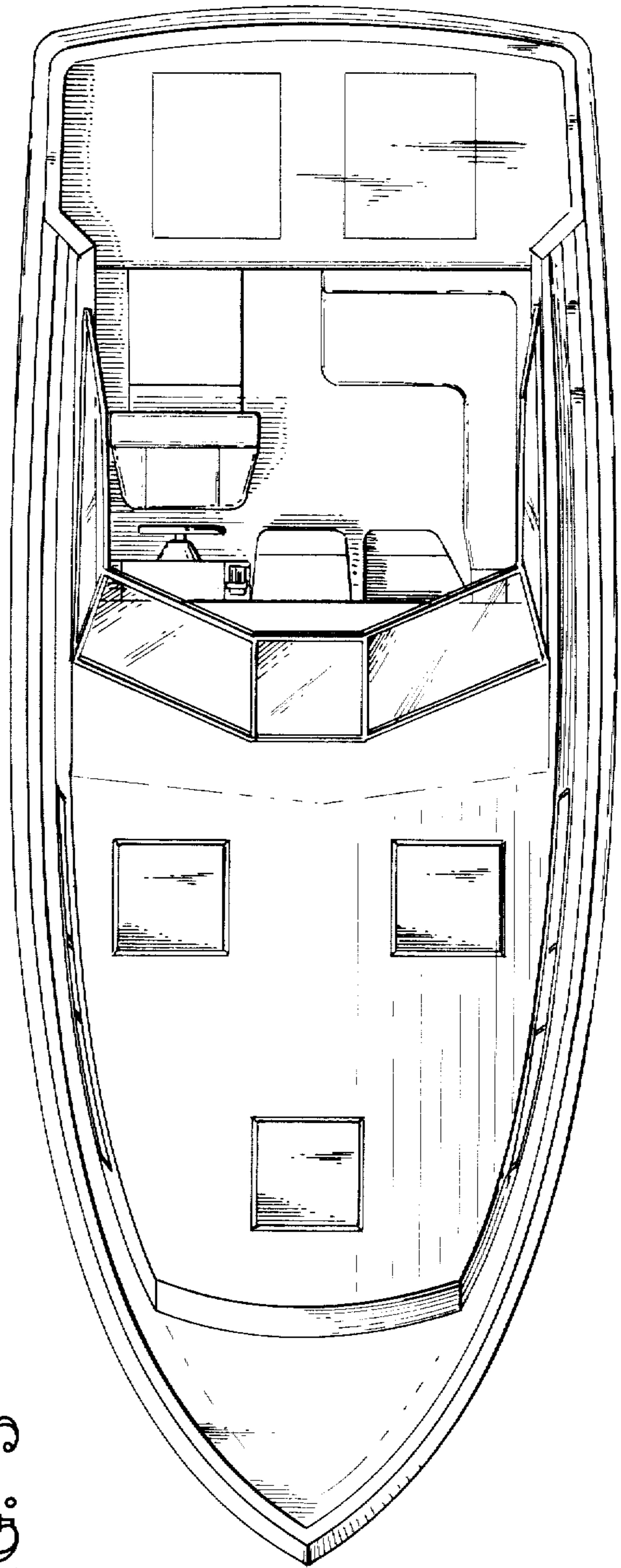

FIG. 3

FIG. 4

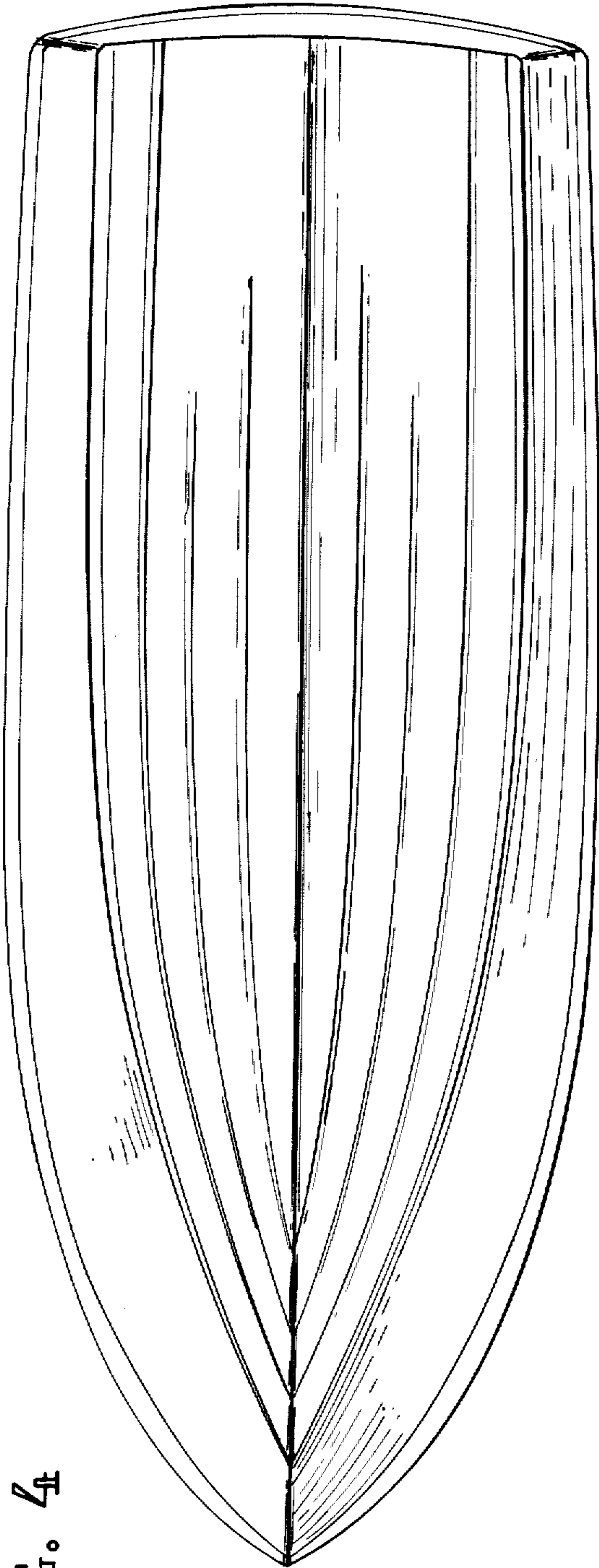

FIG. 5

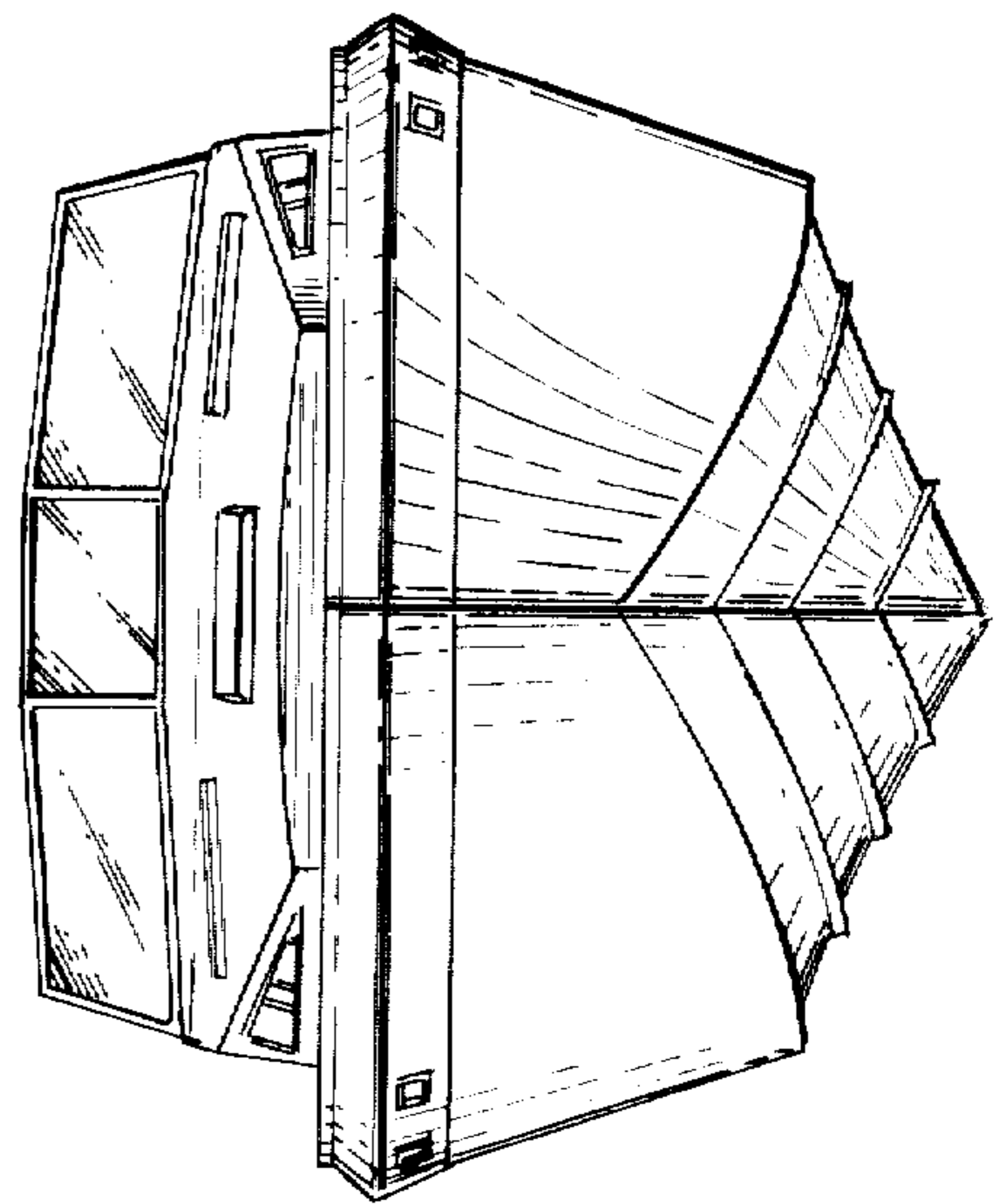

FIG. 6

